

PANEL POWER METERS

PA39 TYPE

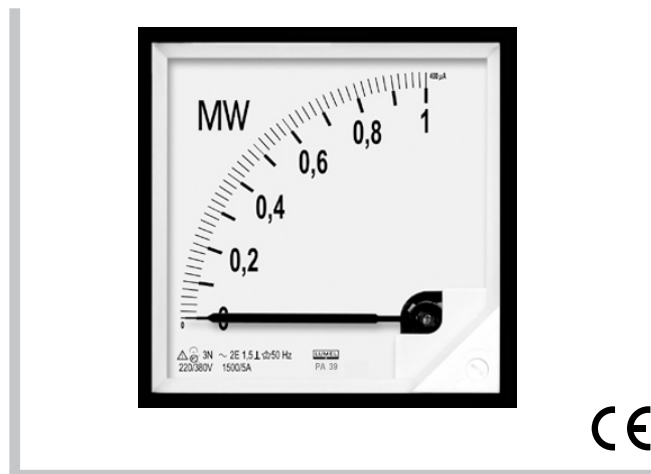

APPLICATION

The PA39 power meter is a moving-coil meter with a built-in measuring transducer. It is destined to measure active or reactive power in a.c. power networks. The measured power is indicated by a magnetoelectric (moving-coil) measuring system.

These meters are delivered in following versions:

- for measuring the active power in single-phase systems,
- for measuring the active or reactive power in three-phase three-wire or four-wire symmetrically or asymmetrically loaded systems,
- with the zero graduation on the left side of the scale for measuring the unidirectional power flow,
- with the zero graduation in the middle of the scale for measuring the bidirectional power flow.

TECHNICAL DATA

Measuring ranges acc. the series	1, 1.2, 1.5, 2, 2.5, 3, 4, 5, 6, 7.5, 8, or the decimal multiplication of one of these numbers
Input voltage	100 $\sqrt{3}$ (x/100/ $\sqrt{3}$), 100 (x/100), 133, 230, 280, 400, 500, 690 V
Input current	1 A (x/1 A), 5 A (x/5 A)
Active power factor	cos ϕ : -0.5 cap...1...0.5 ind
Reactive power factor	sin ϕ : -0.5 cap...1...0.5 ind
Accuracy class	1.5
Rated operating conditions:	
- ambient temperature	5...23...40°C 5...35...55°C (on request, tropical execution)
- relative humidity	25...85%
- frequency of the input quantities	acc. order (table 1)
- working position	acc. order $\pm 5^\circ$ (table 2)
- external magnetic field	≤ 400 A/m

Additional errors acc. EN 60051-1 standard

Power consumption:

- voltage circuit ≤ 3 VA
- current circuit ≤ 0.25 VA

Protection Grade acc. to EN60529

- Front protection grade:
 - IP 50 for PA39 meters
 - **IP 65 for PA39 meters** (on request):
- IP20 terminal protection (with a terminal protection cover)

Electromagnetic compatibility:

- emission acc. EN 61000-6-4 standard
- immunity acc. EN 61000-6-2 standard

The meter fulfils CE mark requirements.

Safety requirements acc. EN 61010-1:

- installation category III
- level of pollution 2
- working voltage in relation to the earth 600 V a.c.

Weight 400 g

ACCESSORIES

We deliver with the meter:

- screw holders (IP50 option)..... 2 pcs
- screw holders (IP65 option)..... 4 pcs
- terminal protection cover..... 1 pc
- user's manual..... 1 pc
- guarantee certificate..... 1 pc

CHOICE OF MEASURING RANGE

1. Calculate the power from the formulas:

$$P = U_n \times I_n \text{ for single-phase networks}$$

$$P = \sqrt{3} \times U_n \times I_n \text{ for three-phase networks}$$

where:

U_n - network rated voltage:

- for three-phase networks - phase-to-phase voltage,
- when connected through transformers-primary rated voltage.

I_n - rated current:

- 5 A or 1 A,
- when connected through transformers-primary rated voltage.

2. Round the calculated power value to the nearest value from the given sequence of numbers for the measuring range.

3. Example of measuring range choice.

Three-phase network; rated values of transformers: 15 000/100 V and 400/5 A

$$P = \sqrt{3} \times 15\,000 \text{ V} \times 400 \text{ A} = 10,39 \text{ MW (Mvar)}$$

Selected measuring range: 10 MW (Mvar)

EXTERNAL DIMENSIONS OF PA39 METER FOR IP 50 PROTECTION GRADE

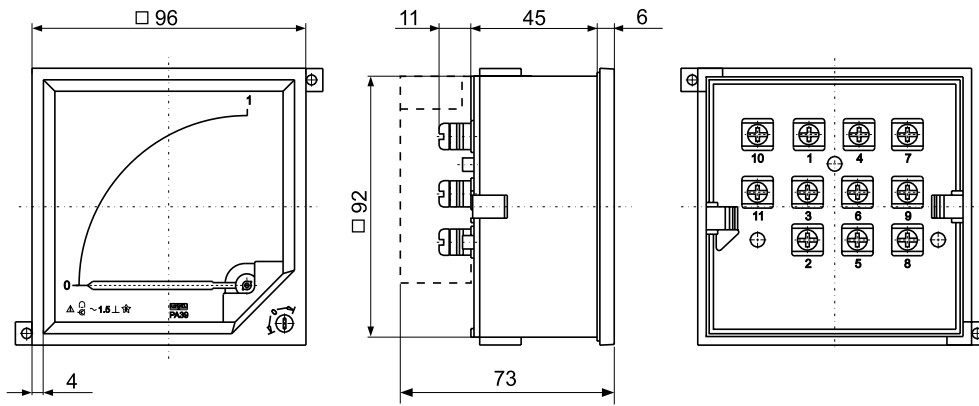
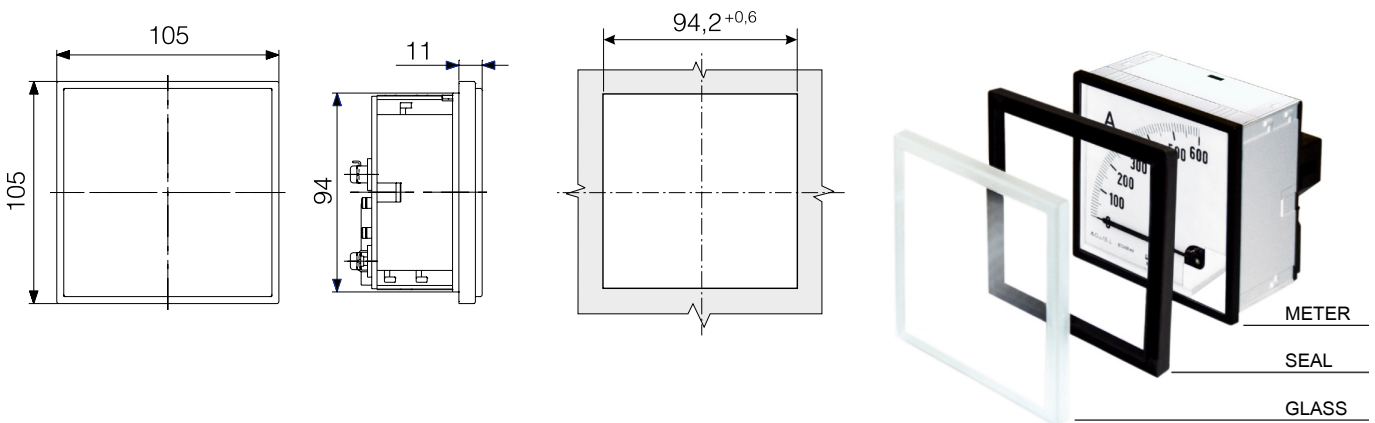

Fig.1. PA39 meter outline drawing.

EXTERNAL DIMENSIONS OF PA39 METER FOR IP 65 PROTECTION GRADE



FIXATION ON THE PANEL

One should prepare in the panel a hole at dimensions: $92^{+0,8} \times 92^{+0,8}$ mm.
 The thickness of the material of which the panel is made, cannot exceed 15 mm.
 The meter is fixed in the panel by two screw holders situated on arbitrary opposite corners of the case.

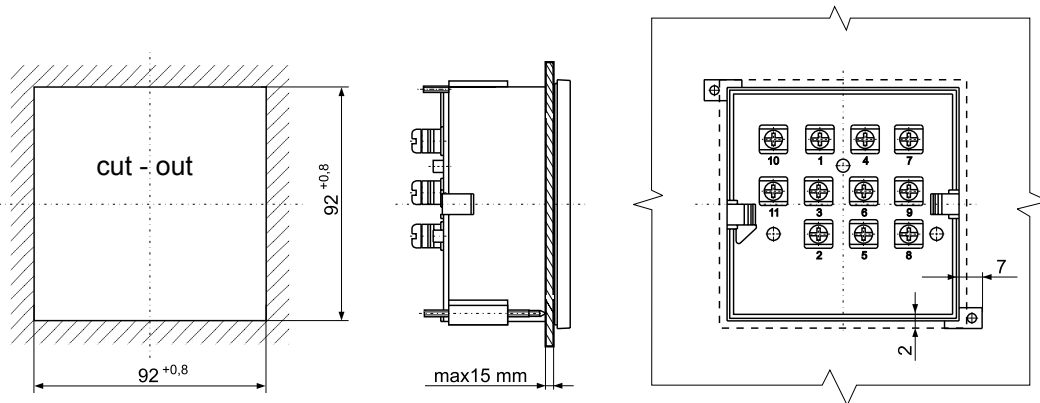

Fig.2. Way of the meter fixation on the panel.

DIAL EXCHANGE

Dials with graduated scales can be interchanged in all PA39 power meters. This is especially convenient for meters destined to co-operate with measuring transformers. In order to exchange the dial, one can take off the plastic cover (1) placed on the upper part of the case and draw out the dial (2) with a suitable tool introduced in the dial perforation. When replacing the new dial, carefully close the slot of the case with the plastic cover (see fig. 1).

NOTE:



When changing the standard rated ranges of PA39 power meters and choosing **Un** or **In** quantities inconsistently with values included in the table 3 (measuring ranges), one must recalibrate these power meters acc. calibration instructions given by the manufacturer in the **Calibration Service Manual** (if ordered).

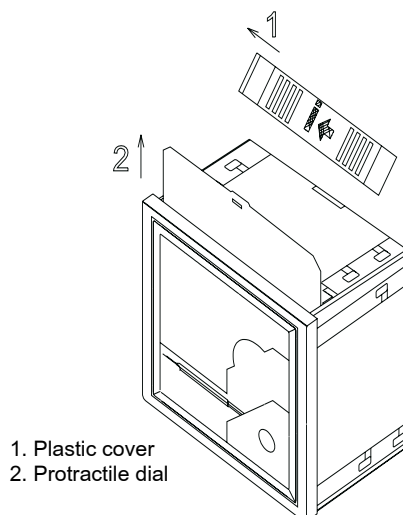

1. Plastic cover
2. Protractile dial

CONNECTION DIAGRAMS OF EXTERNAL CIRCUITS

Measurement of active power in a single-phase network.

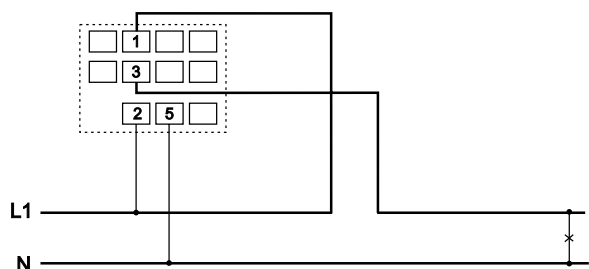

Measurement of active power in a three-phase four-wire symmetrically loaded network.

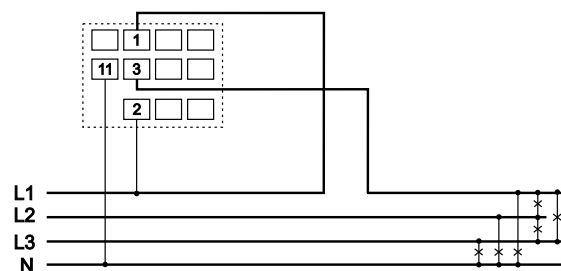

Measurement of active power in a three-phase three-wire symmetrically loaded network.

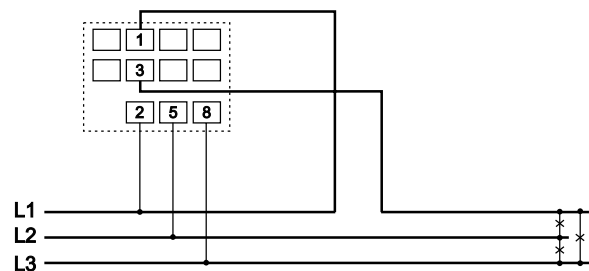

Measurement of active power in a three-phase four-wire asymmetrically loaded network.

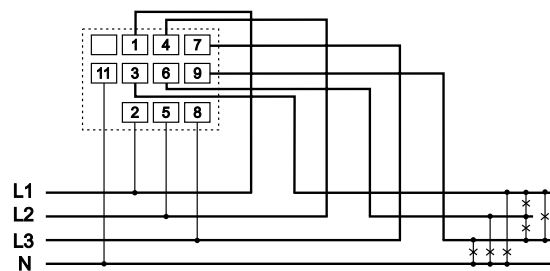

Measurement of active power in a three-phase three-wire asymmetrically loaded network.

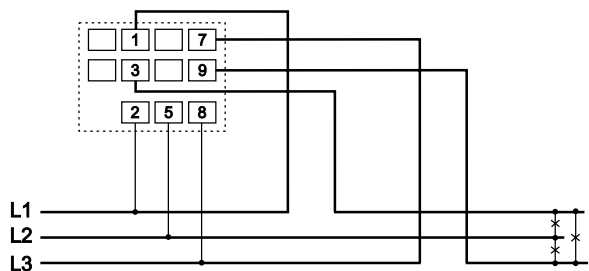

Measurement of reactive power in a three-phase three-wire symmetrically loaded network.

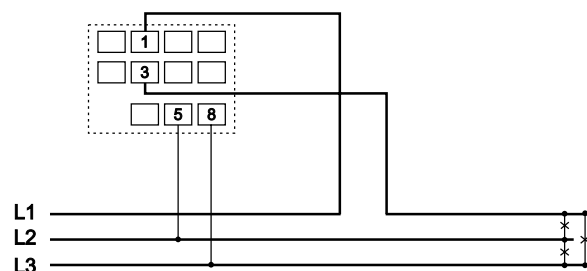

Measurement of reactive power in a three-phase three-wire asymmetrically loaded network.

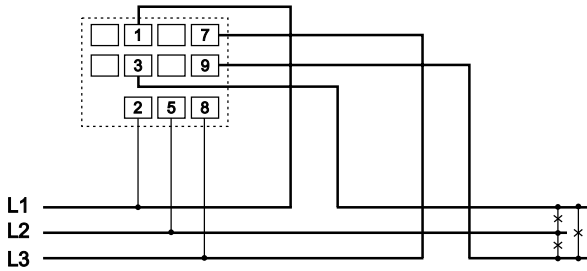

Measurement of reactive power in a three-phase four-wire symmetrically loaded network.

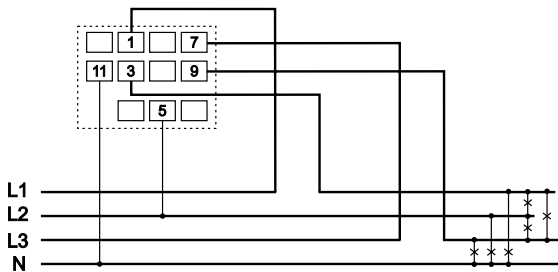

Measurement of reactive power in a three-phase four-wire asymmetrically loaded network.

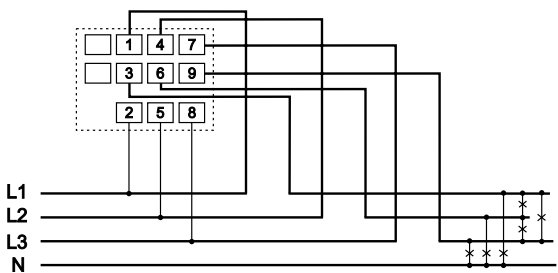

ORDERING PROCEDURE

Table 1

Input voltage frequency f_n (Hz)	Codes
50	0
60	1
400	2

Table 2

Code	Position
O	c3
A	c1
B	c2, $\alpha = 15^\circ$
C	c2, $\alpha = 30^\circ$
D	c2, $\alpha = 45^\circ$
E	c2, $\alpha = 60^\circ$
F	c2, $\alpha = 75^\circ$
H	c4, $\alpha = 105^\circ$
I	c4, $\alpha = 120^\circ$

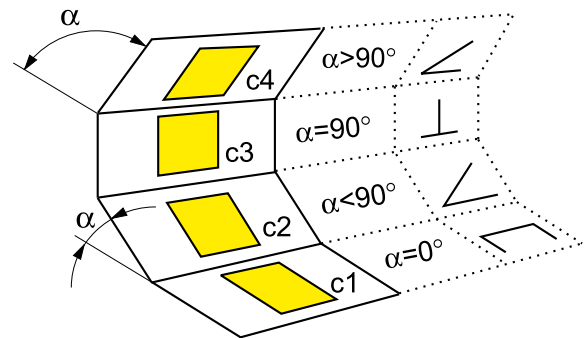

Fig.3. Codes and markings concerning the working position.

ORDERING CODES

Table 4

PANEL POWER METER - PA39	X	X	X	XX	X	X	XX	X
Kind of measured power and measuring system:								
Measurement of active power in a single-phase network.....	A							
Measurement of active power in a 3-phase 3-wire symmetrically loaded network	B							
Measurement of active power in a 3-phase 3-wire asymmetrically loaded network	C							
Measurement of active power in a 3-phase 4-wire symmetrically loaded network	D							
Measurement of active power in a 3-phase 4-wire asymmetrically loaded network	E							
Measurement of reactive power in a 3-phase 3-wire symmetrically loaded network	F							
Measurement of reactive power in a 3-phase 3-wire asymmetrically loaded network	G							
Measurement of reactive power in a 3-phase 4-wire symmetrically loaded network	H							
Measurement of reactive power in a 3-phase 4-wire asymmetrically loaded network	K							
Input voltage								
write in the U_n range code from the table 3.....	X							
Frequency of the input voltage								
write in the frequency code from the table 1	X							
Input current								
write in the I_n range code from the table 3				XX				
Flow direction of the power								
- unidirectional, zero on the left side of the scale							0	
- bidirectional, zero in the middle of the scale							1	
Working position								
write in the working position from the table 2							X	
Versions:								
catalogue							00	
custom-made ¹⁾							XX	
Acceptance tests:								
without additional requirements.....							8	
with a quality inspection certificate							7	
other requirements ²⁾							X	

¹⁾ The ordering code is given by the manufacturer after agreement.

²⁾ The number code is given acc. customer's agreement.

ORDERING WAY

In any order one must specify the name and the ordering code of the power meter using the tables: 1, 2, 3, and 4.

Order example: PA39 - H - F - O - L5 - 0 - O - 00 - 8, means:

H - Reactive PA39 power meter adapted to a three-phase four-wire symmetrically loaded network.

F - Network rated voltage: 3000 V (from table 3).

O - Frequency of the input voltage: 50 Hz (from table 1).

L5 - Network rated current: 300 A (from table 3).

0 - Unidirectional power flow.

O - Working position: C3, vertical (from table 2).

00 - Catalogue version.

8 - without additional requirements concerning acceptance tests.

This power meter is destined to co-operate with **300 A/5 A** transformers and a **3000 V/100/√3 V** voltage transformers.

Note: concerning casing protection grade IP. When ordering, please precise the required grade option: **IP50** or **IP65**