



METER OF NETWORK PARAMETERS

ND20 TYPE



USER'S MANUAL



CONTENTS

- 1. APPLICATION..... 3
- 2. METER SET..... 3
- 3. BASIC REQUIREMENTS AND OPERATIONAL SAFETY 3
- 4. INSTALLATION..... 4
- 5. METER DESCRIPTION 5
- 6. ND20 PROGRAMMING 8
- 7. RS-485 INTERFACE 21
- 8. ERROR CODES 29
- 9. TECHNICAL DATA 30
- 10. ORDERING CODES..... 35

1. APPLICATION

The N20D meter is a digital programmable panel meter destined for the measurement of 3-phase 4-wire network parameters in balanced and unbalanced systems with the simultaneous display of measured quantities and digital transmission of their values. The meter enables the control and optimization of power electronics devices, systems and industrial installation operations

The meter ensures the measurement of: rms values of voltage and current, active, reactive and apparent power, active, reactive energy, power factors, frequency, 15, 30, 60 minutes' mean active power, archive of power profile, THD and harmonic measurements. Additionally, the current value in the neutral wire is calculated. Voltages and currents are multiplied by given voltage and current ratios of measuring transformers. Indications of power and energy take into consideration values of programmed ratios. The value of each measured quantity can be transmitted to the master system through the RS-485 interface. The relay output signals the overflow of the chosen quantity, and the impulse output can be used for the consumption check of 3-phase active and reactive energy. The meter has additionally a continuous current output.

The meter has a galvanic separation between respective blocks:

- supply,
- measuring inputs,
- voltage and current inputs,
- analog output,
- RS-485 output,
- impulse output.

2. METER SET

The set of the ND20 meter is composed of:

- | | |
|--|-------|
| 1. ND20 meter | 1 pc. |
| 2. user's manual | 1 pc. |
| 3. guarantee card | 1 pc |
| 4. seal | 1 pc. |
| 5. holders to fix the meter in the panel | 4 pcs |

3. BASIC REQUIREMENTS AND OPERATIONAL SAFETY

In the safety service scope, the ND20 meter meets to requirements of the EN 61010 -1 standard.

Observations Concerning the Operational Safety



- All operations concerning transport, installation, and commissioning as well as maintenance, must be carried out by qualified, skilled personnel, and national regulations for the prevention of accidents must be observed.

- Before switching the meter on, one must check the correctness of connection to the network.
- Before removing the meter housing, one must switch the supply off and disconnect measuring circuits.
- The removal of the meter housing during the guarantee contract period may cause its cancellation.
- The ND20 meter is destined to be installed and used in industrial electromagnetic environment conditions.
- One must remember that in the building installation, a switch or a circuit-breaker should be installed. This switch should be located near the device, easy accessible by the operator, and suitably marked.

4. INSTALLATION

The ND20 meter is adapted to be fixed on a panel by means of holders. The fitting way is presented on the fig.1.

Housing overall dimensions: 96 x 96 x 77 mm. At the rear side of the meter, there are screw terminal strips which enable the connection of external wires with a cross-section up to 2.5 mm².

One must prepare a 92.5^{+0.6} x 92.5^{+0.6} mm cut-out in the panel. The material thickness which the panel is made from should not exceed 15 mm. Insert the meter from the frontal panel side with the disconnected supply voltage. After the insertion into the hole, fix the meter by means of holders.

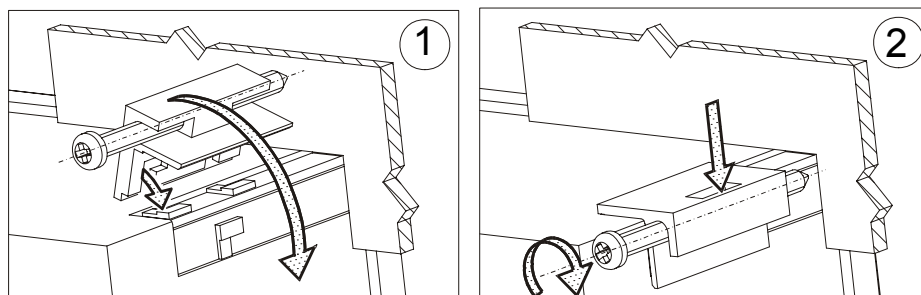

Fig. 1. Meter fitting

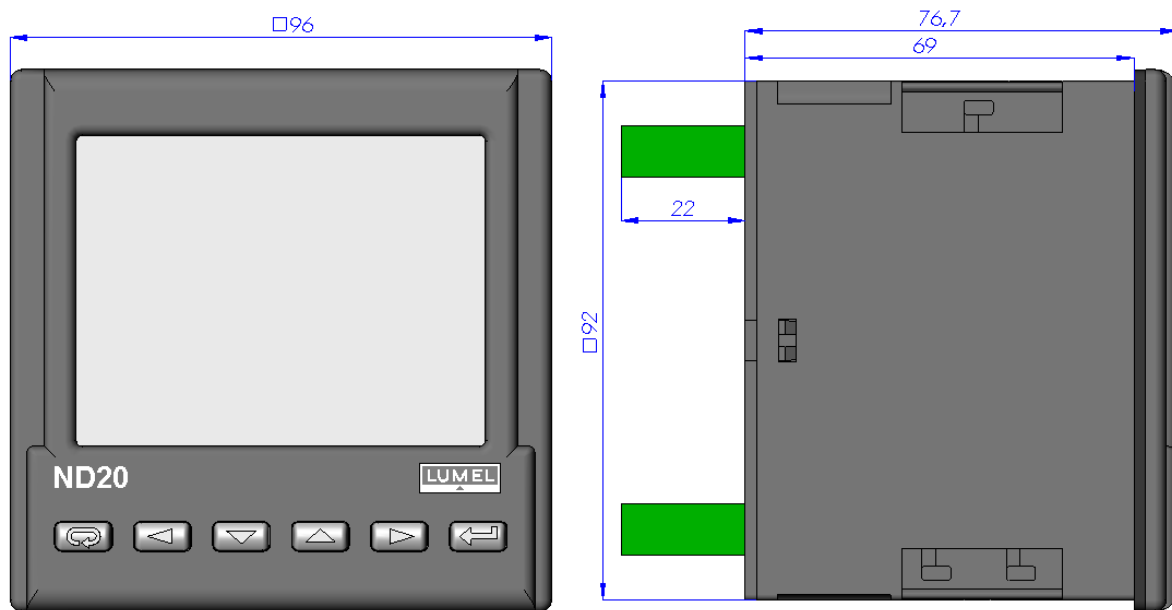

Fig. 2 Meter overall dimensions

5. METER DESCRIPTION

5.1. Current Inputs

All current inputs are galvanically isolated (internal current transformers). The meter is adapted to co-operate with external measuring current transformers. Displayed current values and derivative quantities are automatically recoun in relation to the introduced external current transformer ratio. Current inputs are defined in the order as 1 A or 5 A.

5.2. Voltage Inputs

Quantities on voltage inputs are automatically converted acc. to the introduced ratio of the external voltage transformer. Voltage inputs are defined in the order as 3 x 57.7/100 V, 3 x 230/400 V.

5.3. Connection Diagrams

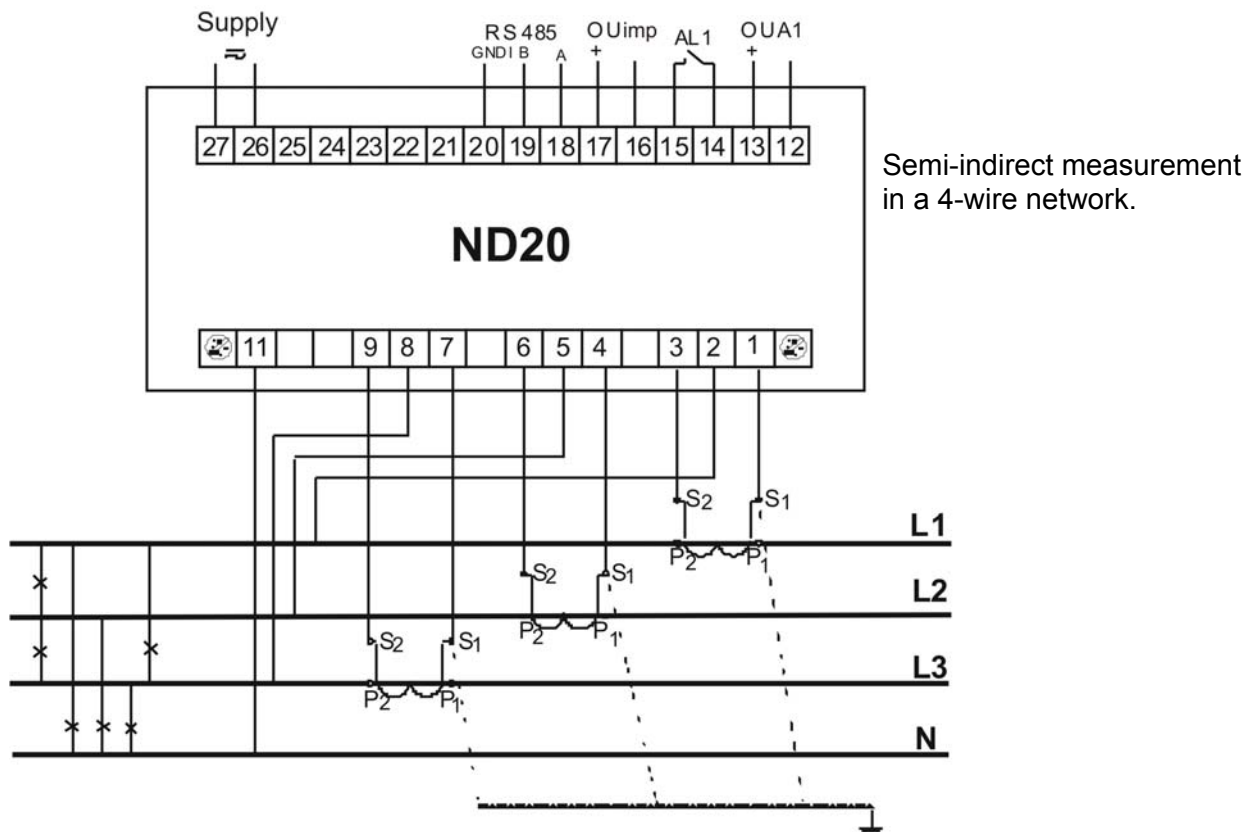
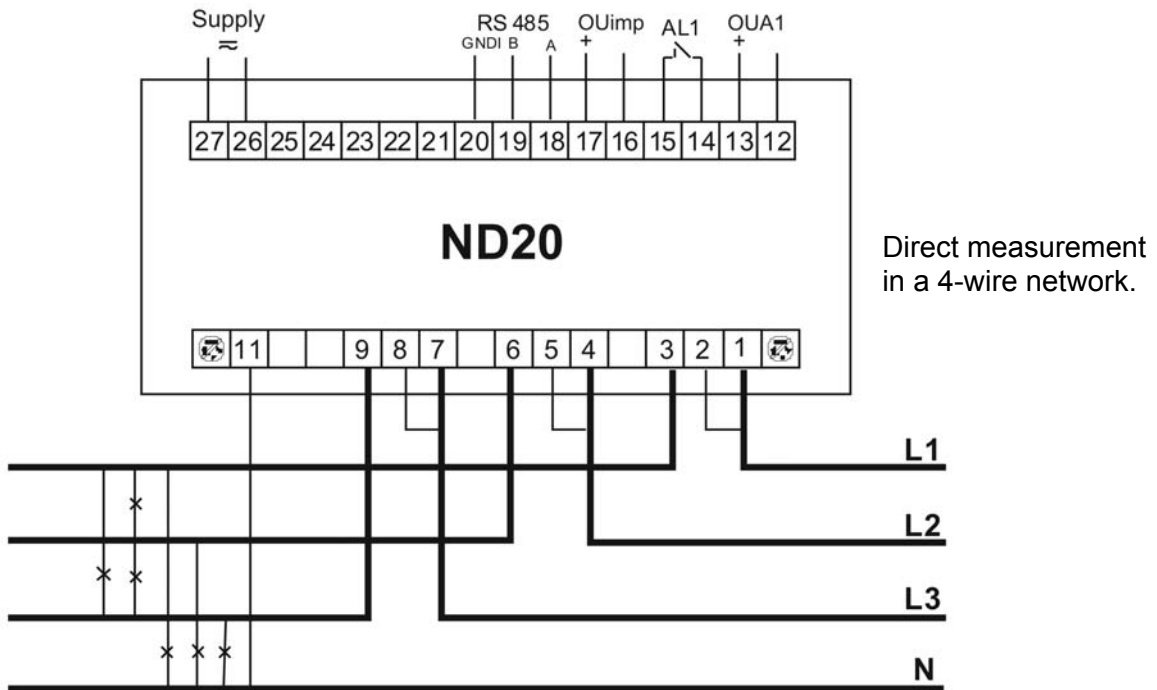

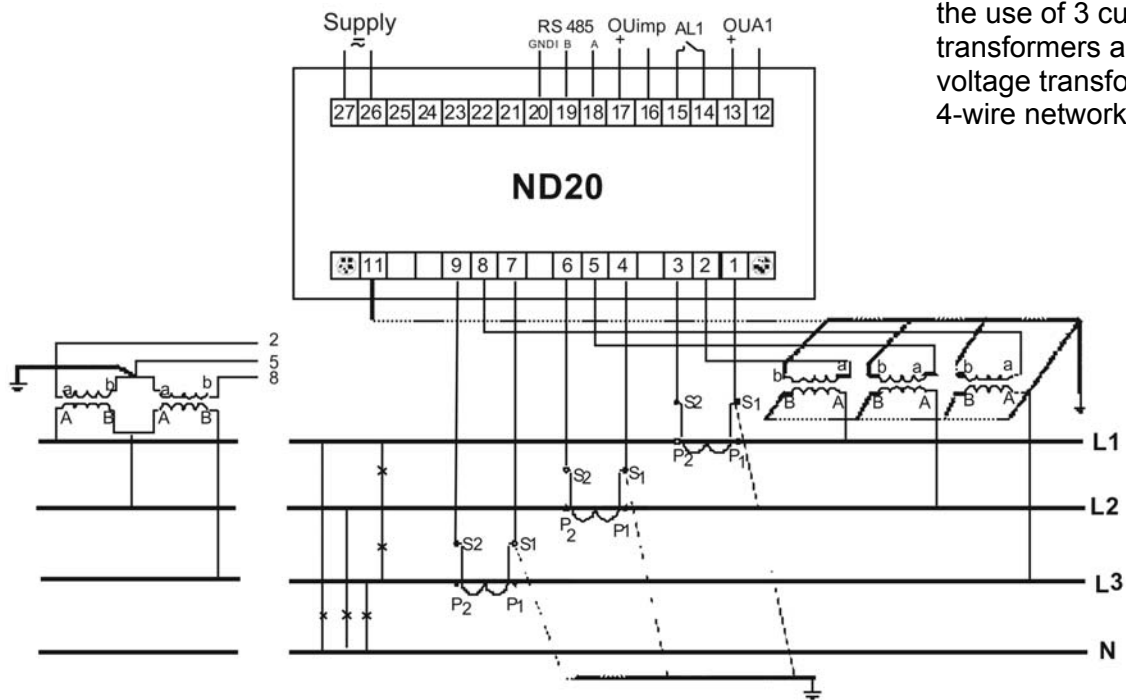

Indirect measurement with the use of 3 current transformers and 2 or 3 voltage transformers in a 4-wire network.

Fig 4. Meter connection diagrams in a 4-wire network.

6. ND20 ProgramMING

6.1. Frontal Panel



Fig 5. Frontal panel

Description of the frontal panel:

1 – abandon push-button – ESC	11 – units of displayed values
2 – push-button to displace to the left	12 – symbols of digital data transmission
3 – push-button to decrease the value	13 – multipliers of basic values
4 – push-button to increase the value	14 – symbols of alarm switching on/occurrence
5 – push-button to displace to the right	15 – symbols of harmonic value, THD display
6 – acceptance push-button - ENTER	16 – symbols of energy flow
7 – symbol of displayed value of averaged active power	17 – symbols of min / max quantities
8 – display field of mean values, frequency, time, power guard	18 – symbols of quantity affiliation to respective phase
9 – display field of basic quantities, energy, THD, harmonics, date (rows 1, 2, 3)	19 – symbols of power, energy character
10 – symbols indicating the display of power factor, power tangent and THD (row 4)	20 – symbol of 3-phase quantity display

6.2. Messages after Switching the Supply on

After switching the supply on, the meter performs the display test and display the *n.n.n* meter name, rated current and voltage, the current program version, and next displays the measured values.

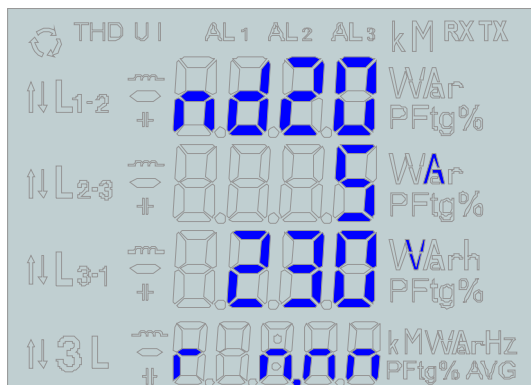

where: *n.n.n* is the number of the current program version or the number of the custom-made version.

Fig. 6. Message after starting the meter

Caution! If on displays the message **Err Cal** or **Err EE** appears, one must contact the service shop.

6.3. Monitoring of Parameters

In the measuring mode, quantities are displayed acc. to settled tables.

The pressure of the push-button (left) or push-button (right) causes the transition between displayed quantities. The pressure of the push-button (Enter) causes the transition between mean and additional displayed values. The pressure of the push-button (down) causes the monitoring of the minimum value, however the pressure of the push-button (up) causes the monitoring of the maximum value.

The pressure of the (ESC) push-button during the monitoring of these values, erases suitably minimum or maximum values. During the operation in the measuring mode of all harmonics (ALL-table 3), instead of harmonic energy, harmonic percentage values are displayed.

Through and push-buttons, one can switch between successive harmonics. The harmonic no is alternately displayed with the value. Through the RS-485 interface one can set up the values, that would be visualized (starting from version 1.02).

The error display is described in the chapter 8.

When displaying the reactive power, a marker indicating the load character is displayed, capacitive (+) or inductive (m)

Displayed quantities in the field 9 (fig. 5.)

Table 1

Backlit symbols		L ₁ ,V L ₂ ,V L ₃ ,V	L ₁₋₂ ,V L ₂₋₃ ,V L ₃₋₁ ,V	L ₁ ,A L ₂ ,A L ₃ ,A	L ₁ ,W L ₂ ,W L ₃ ,W	L ₁ ,Var L ₂ ,Var L ₃ ,Var	L ₁ ,VA L ₂ ,VA L ₃ ,VA	L ₁ ,PF L ₂ ,PF L ₃ ,PF	L ₁ ,tg L ₂ ,tg L ₃ ,tg	kWh
Displayed values	row 1	U1	U12	I1	P1	Q1	S1	PF1	tg1	Imported active energy EnP
	row 2	U2	U23	I2	P2	Q2	S2	PF2	tg2	
	row 3	U3	U31	I3	P3	Q3	S3	PF3	tg3	
Displaying		perma- nent	optional	perma- nent	perma- nent	optional	optional	optional	optional	optional

Backlit symbols		- , kWh	$\overset{\sim}{\text{kVarh}}$	$\overset{\#}{\text{kVarh}}$	L ₁ , THD U L ₂ , THD U L ₃ , THD U	L ₁ , THD I L ₂ , THD I L ₃ , THD I
Displayed values	row 1	exported active energy	reactive inductive energy / reactive positive energy	reactive capacitive energy / reactive negative energy	Uh1 V / THD1 %	Ih1 A / THD1 %
	row 2				Uh2 V / THD2 %	Ih2 A / THD2 %
	row 3				Uh3 V / THD3 %	Ih3 A / THD3 %
Displaying		permanent	optional	permanent	permanent	permanent

Displayed symbols		kWh THD	L ₁ , THD I L ₂ , THD I L ₃ , THD I	kWh THD	L ₁ , THD I L ₃ , THD I L ₂ , THD I	c	
Displayed values	row 1	imported harmonic active energy	Uh1n* %	exported harmonic active energy	Ih1n* %	cos(φ ₁)	year
	row 2		Uh2n* %		Ih2n* %	cos(φ ₂)	month
	row 3		Uh3n* %		Ih3n* %	cos(φ ₃)	day
Displaying		optional	optional	optional	optional	optional	optional

* Harmonic voltage (current) of L1, L2, L3 phases for n-harmonic

Displayed quantities in the field 8 (fig. 5.)

Table 2

Displayed symbols	3L A	A	W	Var	VA	PF	tg	W
Displayed values in the row 4	I _{mean} 3-phase	I _(N)	ΣP 3- phase	ΣQ 3-phase	ΣS 3-phase	PF 3-phase	tg 3-phase	ΣP 3-phase (15 min or 30 min or 60 min)
Displaying	permanent	optional	permanent	permanent	permanent	optional	optional	optional

Backlit symbols	c		Hz	%
Displayed values in the row 4	$\cos(\varphi)$ 3-phase	hour : minutes	frequency	Consumption of ordered power (in 15, 30 or 60 minutes' time)
Displaying	optional	optional	optional	optional

The exceeding of the upper indication range is signaled on the display by upper horizontal lines, however the exceeding of the lower range is signaled by lower horizontal lines.

In case of averaged power measurement $\Sigma P_{3\text{-phase}}$, single measurements are carried out with a 15 seconds' quantum. Suitably to the 15 min, 30 min, 60 min selection, 60, 120 or 240 measurements are averaged. After starting the meter or the power erasing, the first value will be calculated after 15 seconds since the meter switching on or erasing. Till the time to obtain all active power samples, the value of averaged power is calculated from already measured samples.

The current in the neutral wire $I_{(N)}$ is calculated from phase current vectors

The value of consumed ordered power can be used for a previous warning against the exceeding of ordered power and to escape of fines related with it. The consumption of ordered power is calculated on the base of time interval set for the synchronization of the mean active power and the value of ordered power (section 6.5.1). the consumption example is presented in the section 6.5.3.

The alarm switching on is signaled by the lighting of the AL1 inscription (in the mode AL1-3: of AL1, AL2, AL3 inscriptions). The end of alarm duration at the alarm signaling support switched on, is indicated by the pulsation of the AL1 inscription (in the mode AL1-3: of AL1, AL2, AL3 inscriptions).

6.4. Operating Modes

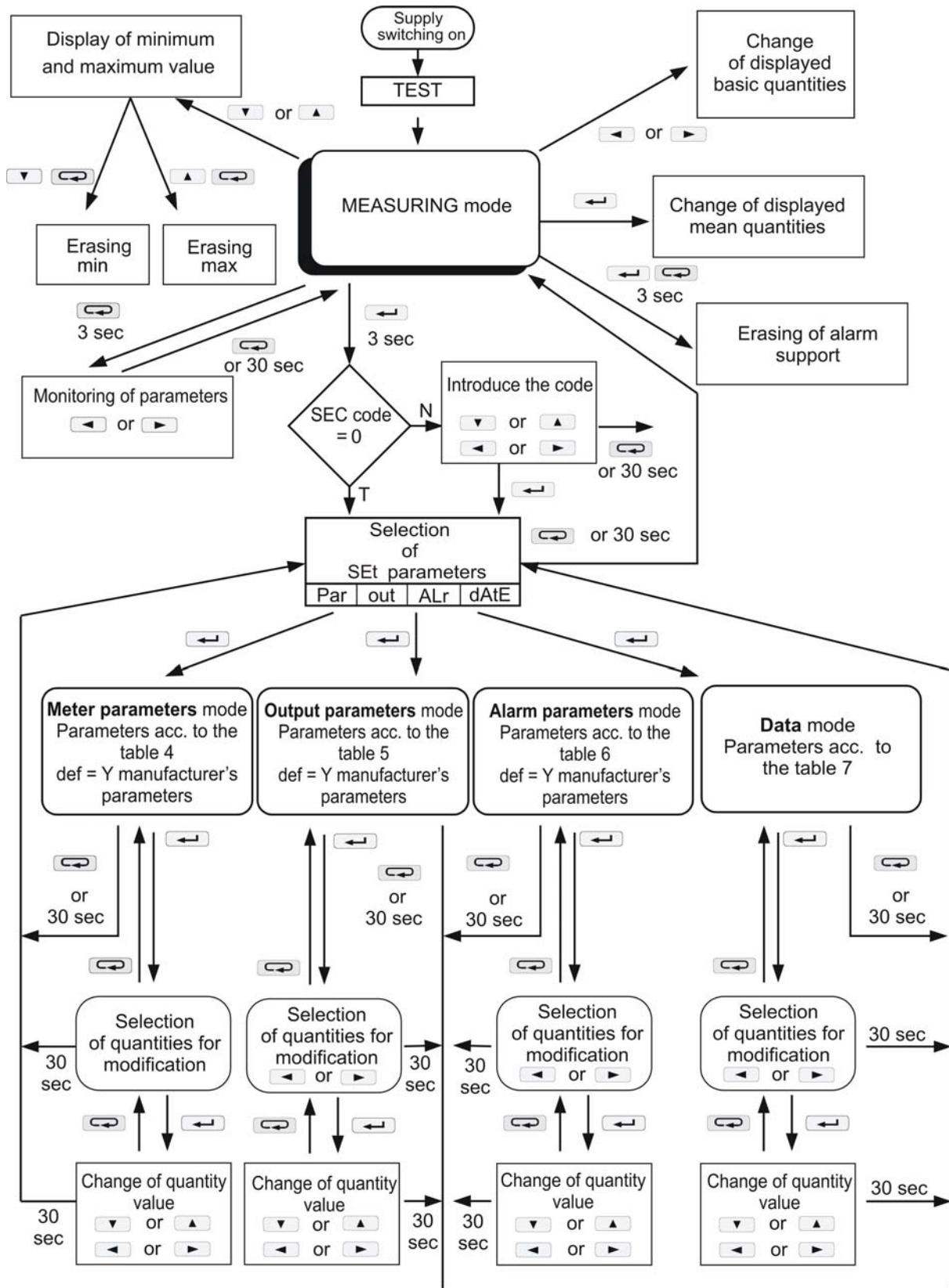

Fig. 7. Operating modes of the ND20 meter.

6.5. Parameter Settings

For the configuration of ND20 meters, a free LPCon software is destined and is available on the www.lumel.com.pl/en/ web site

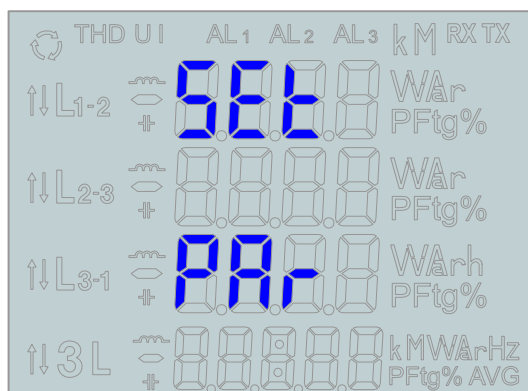



Fig 8. Setup menu

The entry in the programming mode is carried out through the pressure and holding down of the  push-button during ca 3 sec. The entry in the programming mode is protected by the access code. If there is not such a code, the program transits into the programming option. The inscription SET is displayed (in the first row) and the first group of **PAR** parameters. The monitoring of parameters is always available through the pressure and holding down the  push-button during ca 3 sec.

6.5.1. Setting of Meter Parameters



Select the PAR mode in options (by  or  push-buttons) and approve the choice by the  push-button.







Table 3

Item	Parameter name	Designation	Range	Notes/description	Manufacturer's value
1	Introduction of the access code	SECU	oFF, 1... 60000	0 – without code	0
2	Ratio of the current transformer	tr_I	1 ... 10000		1
3	Ratio of the voltage transformer	tr_U	0.1...4000.0		1
4	Synchronization of mean active power	Syn	15, c_15, c_30, c_60	Synchronization of mean active power: 15 - 15 minutes' walking window (record synchronized with the clock every 15 minutes) c_15 – measurement synchronized with the clock every 15 minutes. c_30 – measurement synchronized with the clock every 30 minutes, c_60 – measurement synchronized with the clock every 60 minutes,	15
5	Number of the measured harmonic/THD	nhAr	tHd, ALL, 2...21,	tHd – THD ALL – successive calculations of harmonics inserted in registers	tHd

				2...21 – harmonic number (in this mode, the active energy is calculated)	
6	Storage of minimum and maximum values with errors	erLi	oFF, on	oFF – storage of only correct values (from the measuring range). on – storage of also error occurrences in measurements (values in registers 1e20 and 1e20)	on
7	Way to calculate reactive power	q_t	trGLE, sinUs	TrGLE: $Q = \sqrt{S^2 - P^2}$ sinUs: $Q = \sum_{i=1}^k U_i * I_i * \sin(\angle U_i, I_i)$ k – harmonic number, k = 21 for 50 Hz, k = 18 for 60 Hz	trGLE
8	Way to calculate reactive energy	En_q	cAP, sIGn	cAP – inductive and capacitive energy sIGn – positive and negative energy	cAP
9	Display backlit	diSP	oFF, 1...60, on	off – disabled, on – enabled, 1..60 – time in seconds of backlit support since the push-button pressure.	on
10	Erasing of watt-hour meters	En 0	no, EnP, Enq, EnH, ALL	no – lack of actions, EnP – erasing of active energy, Enq – erasing of reactive energy, EnH – erasing of harmonic energy. ALL – erasing of all energy.	no
11	Erasing of mean active power	PA 0	no, yES	yES – erasing of power	no
12	Erasing of mean active power archive	PAr0	no, yES	yES – erasing of archive	no
13	Ordered power	PAor	0...144.0	Ordered power for forecasting the power consumption in % of the rated value	100.0
14	Manufacturer's parameters	dEf	no, yES	Restoration of manufacturer's parameters of the group.	no

The automatic erasing of energy is carried out:

- for active energy when changing: voltage or current ratio;
- for reactive energy when changing: voltage or current ratio, the way of reactive power calculation;
- for energy of harmonics when changing: voltage or current ratio, when changing the measured harmonic number.

Values are set by means of  and  push-buttons, however the position of the set digit is selected by means of  and  push-buttons. The active position is signaled by the cursor. The value is accepted by the  push-button and resigned by the pressure of the  push-button. During the acceptance, the value insertion possibility in the range is checked. In case when the value is set beyond the range, the meter remains in the parameter edition mode, however the value is set on the maximum value (when the value is too higher) or on the minimum value (when the value is too lower).

6.5.2. Setting of Output Parameters

Select the **out** mode in options and approve the choice by the  push-button.

Table 4

Item	Parameter name	Designation	Range	Notes/description	Manufacturer's value
1	Quantity on the continuous output (code acc. to the table 6)	An_n	table 6		oFF
2	Type of continuous output	An_A	0_20, 4_20	The selection 4_20 causes the switching on of the minimum output current limitation on the level ca 3.8 mA.	0_20
3	Lower value of the input range	AnIL	-144.0...144.0	in % of the rated quantity value	0
4	Upper value of the input range	AnIH	-144.0...144.0	w % of the rated quantity value	100.0
5	Lower value of the output range	AnOL	0.00 ... 24.00	in mA	0
6	Upper value of the output range	AnOH	0.00 ... 24.00	in mA	20
7	Output operation mode	Antr	nor, AnOL, AnOH	Operating mode of the continuous output: nor – normal work, AnoOL – set value AnOL, AnoOH – set value AnOH,	nor
8	Output value at error	AnEr	0 ... 24	in mA	24
9	Number of impulses	lo_n	5000 ... 20000	Number of impulses for 1 kWh	5000
10	Address in MODBUS network	Adr	1...247		1
11	Transmission mode	trYb	8n2, 8e1, 8o1, 8n1		8n2
12	Baud rate	bAUd	4.8 k, 9.6 k, 19.2 k, 38.4 k		9.6 k
13	Manufacturer's parameters	dEf	no, yES	Restoration of manufacturer's parameters of the group	no

6.5.3. Setting of Alarm Parameters



Select the **ALr** mode in options and approve the choice by the  push-button.

Table 5

Item	Parameter name	Designation	Range	Notes/description	Manufacturer's value
1	Quantity in the alarm output (code acc. to the table 6)	AL_n	Table 6		P
2	Alarm type	AL_t	n-on, n-oFF, on,oFF, Hon, HoFF, AL1-3	Fig. 9.	n-on
3	Lower value of the input range	ALoF	-144.0...144.0	in % of the rated quantity value	99
4	Upper value of the input range	ALon	-144,0...144,0	in % of the rated quantity value	101

5	Time delay of the switching reaction	ALdt	0 ... 900	in seconds (for quantities AL_n =P_ord. the delay occurs only when switching the alarm on.	0
6	Support of the alarm occurrence signaling	AL_S	oFF, on	In the situation when the support function is enabled, after the retreat of the alarm state the alarm symbol is not blanked but begins to pulsate. In the AL1-3 alarm mode, the signaling support is always enabled, independently of the setting. The signaling exists till the moment of blanking it by means of the  and  push-buttons combination (during 3 seconds). The function concerns only and exclusively the alarm signaling, then relay contacts will be active without support, acc. to the selected type of alarm.	oFF
7	Interlocking of a renewed alarm switching on	AL_b	0...900	in seconds	0
8	Manufacturer's parameters	dEf	no, yES	Restoration of manufacturer's parameters of the group.	no

The write of the value ALon lower than ALoF switches the alarm off.

Selection of the monitored value:

Table 6

Item/ value in register 4015	Displayed parameter	Kind of quantity	Value for the percentage conversion of alarm values and outputs (100%)
00	off	lack of quantity /alarm disabled/	none
01	U_1	voltage of phase L1	Un [V] *
02	I_1	current in the phase wire L1	In [A] *
03	P_1	active power of phase L1	Un x In x cos(0°) [W] *
04	q_1	reactive power of phase L1	Un x In x sin(90°) [var] *
05	S_1	apparent power of phase L1	Un x In [VA] *
06	PF1	active power factor of phase L1	1
07	tg1	tgφ coefficient of phase L1	1
08	U_2	voltage of phase L2	Un [V] *
09	I_2	current in the phase wire L2	In [A] *
10	P_2	active power of phase L2	Un x In x cos(0°) [W] *
11	q_2	reactive power of phase L2	Un x In x sin(90°) [var] *
12	S_2	apparent power of phase L2	Un x In [VA] *
13	PF2	active power factor of phase L2	1
14	tg2	tgφ coefficient of phase L2	1

15	U ₃	voltage of phase L3	Un [V] *
16	I ₃	current in the phase wire L3	In [A] *
17	P ₃	active power of phase L3	Un x In x cos(0°) [W] *
18	q ₃	reactive power of phase L3	Un x In x sin(90°) [var] *
19	S ₃	apparent power of phase L3	Un x In [VA] *
20	PF3	active power factor of phase L3	1
21	tg3	tgφ coefficient of phase L3	1
22	U _A	mean 3-phase voltage	Un [V] *
23	I _A	mean 3-phase current	In [A] *
24	P	3-phase active power (P1 + P2+ P3)	3 x Un x In x cos(0°) [W] *
25	q	3-phase reactive Power (Q1 + Q2 + Q3)	3 x Un x In x sin(90°) [var] *
26	S	3-phase apparent Power (S1 + S2 + S3)	3x Un x In [VA] *
27	PF _A	3-phase active power factor	1
28	Tg _A	3-phase tgφ coefficient	1
29	FrEq	frequency	100 [Hz]
30	U12	phase-to-phase voltage L1-L2	$\sqrt{3}$ Un [V] *
31	U23	phase-to-phase voltage L2-L3	$\sqrt{3}$ Un [V] *
32	U31	phase-to-phase voltage L3-L1	$\sqrt{3}$ Un [V] *
33	U4 _A	mean phase-to-phase voltage	$\sqrt{3}$ Un [V] *
34	P _{At}	mean active power	3 x Un x In x cos(0°) [W] *
35	P _{ord}	Used percentage of the ordered active power (consumed energy)	100%

*Un, In – rated values of voltages and currents

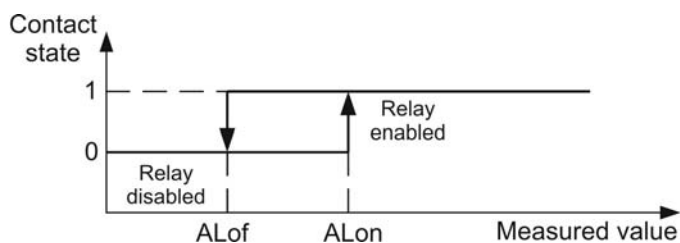

a) n-on

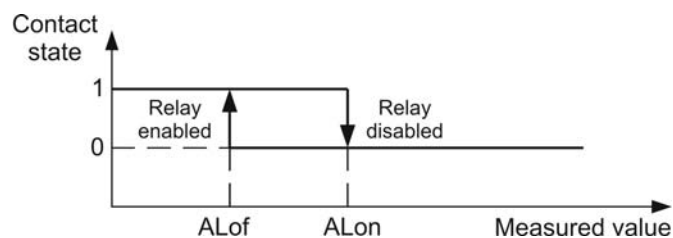

b) n-OFF

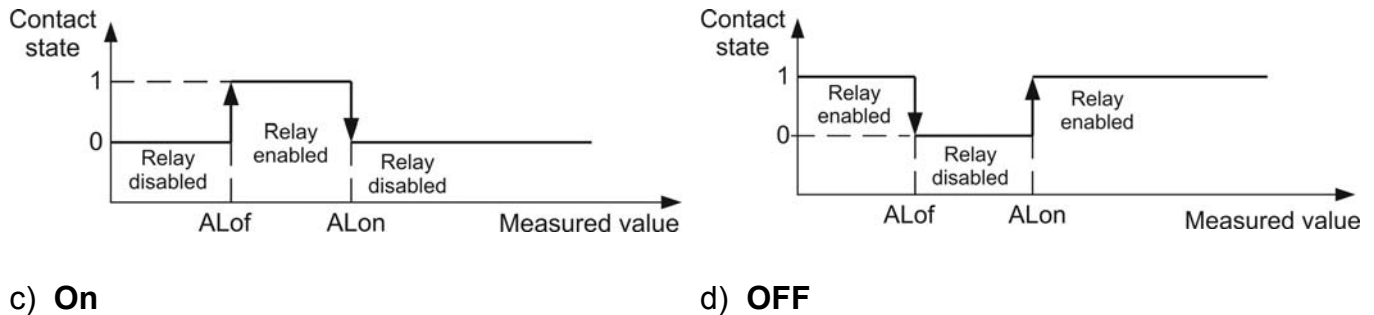



Fig. 9. Alarm types: a),b) normal c) disabled d) enabled.

Remaining types of the alarm:

- H-on – always enabled;
- H-oFF – always disabled,
- AL1-3 – in this mode, the alarm quantity must be from the range:0-7. When the alarm appears on whichever phase, the relay will be enabled and the suitable symbol will be lighted
- (AL1 – phase 1, AL2 – phase 2, AL3 – phase 3. It will be disabled only when all alarms disappear. Alarms operate in the n-on mode with identical hysteresis thresholds ALof and ALon for each phase. The alarm condition withdraw is signaled by the pulsation of the alarm symbol regardless of the set support value of the alarm signaling. The blanking of the signaling support follows after pressing  and  push-buttons (during 3 sec).

Example no 1 of alarm setting:

Set the alarm of **n-on** type for the monitored quantity P – 3-phase active power, version: 5 A; 3 x 230/400 V. Switching the alarm on, after exceeding 3800 W, switching the alarm off after decreasing 3100 W.

Calculate: rated 3-phase active power: $P = 3 \times 230 \text{ V} \times 5 \text{ A} = 3450 \text{ W}$

3450 W – 100 % 3450 W – 100 %
 3800 W – ALon % 3100 W – ALoF %

It appears: ALon = 110 % ALoF = 90 %

Set: Monitored quantity: P; Kind of alarm: n-on, ALon 110, ALoF 90.0.

Example no 2 of alarm setting:

Set the alarm of earliest warning about the possibility to exceed the ordered 1 MW power on the level 90% at the hourly accounting. Measuring current transformer 2500:5 A, voltage : 230 V, Instantaneous maximum import of power: 1.5 MW.

Calculate: rated 3-phase active power of the ND20 meter: $P = 3 \times 230 \text{ V} \times 2500 \text{ A} (500 * 5 \text{ A}) = 1.725 \text{ MW} (500 * 3450 \text{ W}) - 100\%$;

$90\% \text{ of ordered power / rated power} = 90.0\% * 1 \text{ MW} / 1.725 \text{ MW} = 52.1 \%$ of the rated meter value (rounding down).

The' ordered hourly power (energy for consumption): $1 \text{ MWh} / 4 \text{ quarters} = 900 \text{ MWs}$, $90\% - 810 \text{ MWs}$. Remaining 10% at maximum power import would be used in time: $900 \text{ MWs} / 1.5 \text{ MW} = 60 \text{ s}$

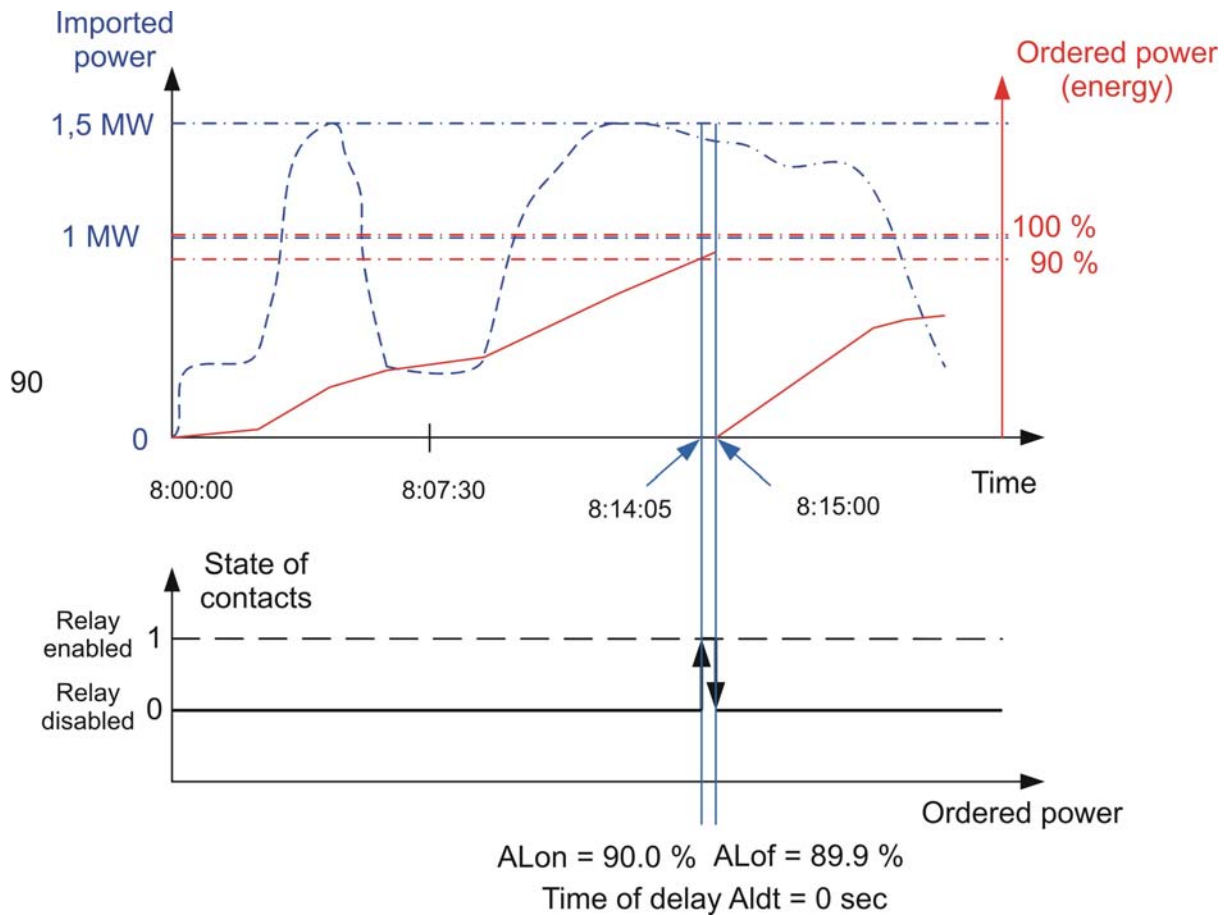

Fig 10. Measurement of used ordered 15 minutes' active power consumption synchronized with the clock, with alarm set on a 90% consumption.

Set: Monitored quantity:P_ord, Kind of alarm: n-on, ALon = 90.0, ALoF = 89.9, Tr_1 = 500, Syn = c_60, Time delay ALdt = 0 or 240 s.

An example of the parameter value utilization of ordered active power to switch the alarm on is presented on the fig. 10.

The time delay is set on 0 sec.

In the calculated example, for remaining 10% of ordered power, at the maximum power consumption, devices could still work during 60 sec without exposing customers to fines. when setting the time delay ALdt on 60 sec, the alarm would not be enabled.

6.5.4. Setting Date and Time

Select the **dAtE** mode in options and approve the choice by the  push-button. Seconds are reset after setting hour and minute values.

Table 7

Lp.	Parameter name	Designation	range	Remarks/description	Manufacturer's value
1	Hour, minute	t_H	0...23, 0..59		0.00
2	Month, day	t_d	1...12, 1...31		1.01
3	Year	t_y	2001 ... 2100		2001

6.6. Configuration of THD Measurement, Harmonics and Energy for the Harmonic

The meter has 3 work modes related to the THD and harmonic calculation. When setting the parameter of the harmonic number:

- tHd – the meter measures every 1 second only the THD value for currents and voltages, the result is exposed on the display and expressed in registers in percentages. Energy of harmonics is reset and particular harmonics include the error value (1e20);

- All – the meter measures harmonics from 2 up to 21, for 50 Hz frequency (from 2 up to 18 for 60 Hz frequency). Energy of harmonics is reset.

- 2 – 21 – measurement of the selected harmonic value, every 1 second, the result is exposed on the display and in basic units (V, A) in registers. Energy for the given harmonic is counted up.

The switching of the harmonic number or the change of voltage or current ratio resets energy for harmonics.

6.7. Archive – Active Power Profile

The ND20 meter is equipped with an archive allowing to store up to 9000 measurements of mean active power. Mean active power P_{AV} is archived with a 15, 30, 60 minutes' interval of time, synchronized with the real time clock. In case of operation in the 15 minutes' walking window mode, the archiving is performed in the same way as for the 15 minutes' interval of time (fig. 11). The direct access to the archive is for 15 records including the date, time and value placed in the range of addresses 1000 -1077. The position of the first (oldest) archived sample is placed in the register 1000, however the position of the last archived sample (youngest) is placed in the register 1001. the value of the first record, from 15 available records placed in registers 1003 – 1077, is written in the register 1002. The write of the first read out record value (1 – 9000) causes the data updating of 15 records for readout.

In registers, in which samples were not already been written, are 1e20 values.

The archive is organized in the shape of a circular buffer. After writing the 9000 th value, the next overwrites the oldest with number 0, and the successive, the next with number 1, etc.

If the value of the register 1000 is higher than 1001, that means that the buffer was overflowed one time at least. Eg, the value 15 in the register 1000, and 14 in the register 1001 means, that there were already more than nine thousand samples and oldest samples are from the record 15 up to 9000, next from the record 1 to the youngest record with number 14.

The change of the current or voltage ratio, kind of mean power, causes the archive erasing.

The reset of averaged power or the change of averaging time does not erase the archive.

The automatic erasing of the archive and averaged power is performed when changing the voltage or current ratio.

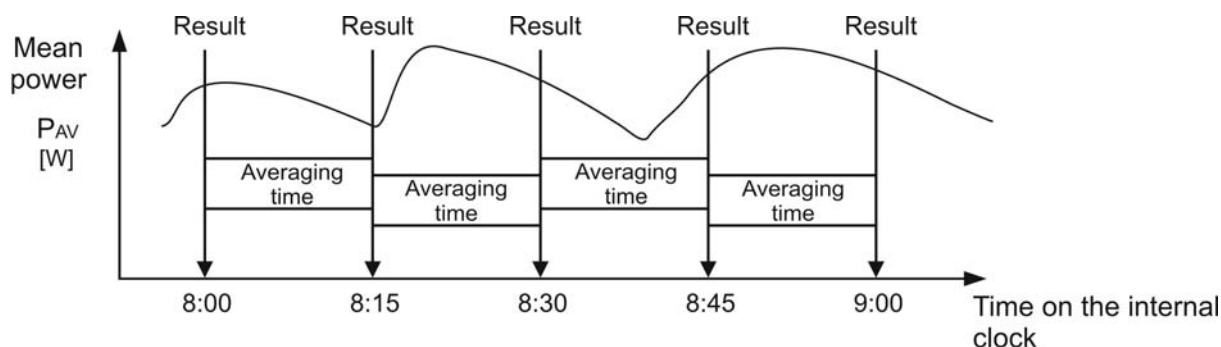

Fig. 10. Measurement of 15 minutes' mean active power synchronized with the clock.

7. RS-485 INTERFACE

Parameter set of the serial ND20 meter link:

- identifier: 0xBC
- meter address: 1..247
- baud rate: 4.8, 9.6, 19.2, 38.4 kbit/s,
- working mode: Modbus RTU,
- information unit: 8N2, 8E1, 8O1, 8N1,
- maximum response time when requesting for archive: 600 ms.
- maximum response time at remaining requests: 750 ms.
- maximum quantity of read out registers in one request
 - 40 registers – 4-byte registers
 - 80 registers – 2-byte registers
- implemented functions: 03, 16, 17,
 - 03 - readout of registers,
 - 16 - write of registers,
 - 17 - device identification,

Manufacturer's settings: address 1, baud rate: 9600 baud, RTU 8N2 mode,

Map of ND20 meter registers

In the ND20 meter, data are placed in 16 and 32-bit registers. Process variables and meter parameters are placed in the address area of registers in a way depended on the variable value type. Bits in 16-bit registers are numbered from the youngest to the oldest (b0-b15). 32-bit registers include numbers of float type in IEEE-754 standard. Sequence of 3210 bytes – the oldest is transmitted as the first.

Table 8

Address range	Type of value	Description
1000 – 1077	Integer (16 bits)/ record	Archive of the averaged power profile. The table 9 includes the register description.
4000 – 4055	Integer (16 bits)	The value is placed in one 16-bit register. The table 10 includes the register description. Registers for write and readout.
7000 – 7121	Float (2x16 bits)	Value placed in two successive 16-bit registers. Registers include the same data as 32-bit registers from the area 7500 – 7659. Registers for readout. Sequence of bytes (3-2-1-0).
7500 – 7659	Float (32 bits)	Value placed in one 32-bit register. The table 11 includes the register description. Registers for readout.
7800 – 8038	Float (2x16 bits)	Value placed in two successive 16-bit registers. Registers include the same data as 32-bit registers from the area 7660 – 7779. Registers for readout. Sequence of bytes (3-2-1-0).
7660 – 7779	Float (32 bits)	Value placed in one 32-bit register. The table 11 includes the register description. Registers for readout.

Table 9

Address of 16 bit-registers	Operations	Description
1000	R	Position of oldest archived mean power.
1001	R	Position of youngest archived mean power
1002	R/W	First available record – NrBL (range 1...9000)
1003	R	Year of archived mean power with number NrBL + 0
1004	R	Month * 100 + day of archived mean power with number NrBL + 0
1005	R	Hour * 100 + minute of archived mean power with number NrBL + 0
1006	R	Value of archived mean power with number NrBL + 0
1007	R	float type – 4 bytes in sequence 3-2-1-0
1008	R	Year of archived mean power with number NrBL + 1
1009	R	Month * 100 + day of archived mean power with number NrBL + 1
1010	R	Hour * 100 + minute of archived mean power with number NrBL + 1
1011	R	Value of archived mean power with number NrBL + 1
1012	R	float type – 4 bytes in sequence 3-2-1-0
...
1073	R	Year of archived mean power with number NrBL + 14
1074	R	Month, day of archived mean power with number NrBL + 14
1075	R	Hour, minute of archived mean power with number NrBL + 14
1076	R	Value of archived mean power with number NrBL + 14
1077	R	float type – 4 bytes in sequence 3-2-1-0

Table 10

Register address	Operation	Range	Description	By default
4000	RW	0...60000	Protection - password	0
4001	RW	0...900 [s]	Interlocking time of the renewed switching of the relay output on	0
4002	RW	0...1200 [%]	Ordered mean power *10 of nominal signals	1000
4003	RW	0	Current transformer ratio	0

4002	RW	0	Reserved	0
4003	RW	1...10000	Current transformer ratio	1
4004	RW	1...40000	Voltage transformer ratio *10	10
4005	RW	0..3	Synchronization of mean active power: 0 – 15 minutes' walking window (record synchronized every 15 minutes with the clock) 1 – measurement synchronized every 15 minutes with the clock 2 – measurement synchronized every 30 minutes with the clock 3 – measurement synchronized every 60 minutes with the clock	0
4006	RW	0...22	Number of the measured harmonic/ 0 – THD, 1 – all harmonics are successively measured and placed in registers 7660-7780, 2...21 – harmonic number with energy.	0
4007	RW	0,1	Storage way of minimum and maximum values 0 – without errors, 1 – with errors	0
4008	RW	0.1	Way to calculate reactive power: $0 - Q = \sqrt{S^2 - P^2}$ $1 - Q = \sum_{i=1}^k U_i * I_i * \sin(\angle U_i, I_i)$ k – harmonic number, k = 21 for 50 Hz k = 18 dla 60 Hz	0
4009	RW	0.1	Way to calculate reactive energy: 0 – inductive and capacitive energy 1 – positive and negative energy	0
4010	RW	0...61	Display backlit: 0 – disabled, 1-60 – backlit time in seconds since the push-button pressure, 61 – always enabled	61
4011	RW	0...4	Erasing of watt-hour meters: 0 – without changes, 1- erase active energy, 2 – erase reactive energy, 3 – erase energy of harmonics, 4 – erase all energy.	0
4012	RW	0.1	Erasing of mean active power P_{AV}	0
4013	RW	0.1	Erasing of the averaged power archive	0
4014	RW	0.1	Erase min and max	0
4015	RW	0.1..35	Quantity on the alarm relay output (code acc. to the table 6)	24
4016	RW	0..6	Output type: 0 – n-on, 1– n-OFF, 2 – on, 3 - OFF, 4 – H-on, 5 – H-OFF, 6 - AL1-3	0
4017	RW	-1440...0...1440 [‰]	Lower alarm switching value of the ratek input range	990
4018	RW	-1440...0...440 [‰]	Upper alarm switching value of the ratek input range	1010
4019	RW	0..900 s	Delay of the alarm switching (for quantity AL_n = P_ord – rgister 4015 =35, the delay occurs only when the alarm is switched on.	0
4020	RW	0.1	Alarm signaling support	0
4021	RW	0,1..35	Quantity on the continuous output no 1/ code acc. to the table 6 /	24
4022	RW	0.1	Continuous output type: 0 – 0...20 mA; 1 – 4...20 mA	0
4023	RW	-1440..0..1440 [‰]	Lower value of the input range in [‰] of the rated input range.	0

4024	RW	-1440..0..1440 [‰]	Upper value of the input range in [‰] of the rated input range.	1000
4025	RW	-2000..0..2000 [10 uA]	Lower output range value of the output [10 uA]	0
4026	RW	1..2000 [10 uA]	Upper output range value of the output [10 uA]	2000
4027	RW	0..2	Manual switching of the analog output 1: 0 – normal work, 1 – set value from the register 4026, 2- set value from the register 4027,	0
4028	RW	0...24 [mA]	Analog output value when error	24
4029	RW	1000...20000	Number of impulses for the impulse output	5000
4030	RW	1..247	Address in the MODBUS network	1
4031	RW	0..3	Transmission mode: 0->8n2, 1->8e1, 2->8o1, 3 ->8n1	0
4032	RW	0..3	Baud rate: 0->4800, 1->9600 2->19200, 3 ->38400	1
4033	RW	0.1	Update the transmission parameter change	0
4034	RW	0...2359	Hour *100 + Minutes	0
4035	RW	101...1231	Month * 100 + day	101
4036	RW	2009...2100	Year	2009
4037	RW	0,1	Record of standard parameters (together with the reset of energy and min, max, averaged power)	0
4038	RW	0..15258	Imported active energy, two older bytes	0
4039	RW	0..65535	Imported active energy, two younger bytes	0
4040	RW	0..15258	Exported active energy, two older bytes	0
4041	RW	0..65535	exported active energy, two younger bytes	0
4042	RW	0..15258	Reactive inductive energy, two older bytes	
4043	R	0..65535	Reactive inductive energy, two younger bytes	
4044	R	0..15258	Reactive capacitive energy, two older bytes	0
4045	R	0..65535	Reactive capacitive energy, two younger bytes	0
4046	R	0..15258	Imported harmonic active energy, two older bytes	0
4047	R	0..65535	Imported harmonic active energy, two younger bytes	0
4048	R	0..15258	Exported harmonic active energy, two older bytes	0
4049	R	0..65535	Exported harmonic active energy, two younger bytes	0
4050	R	0..65535	Status register – description below	0
4051	R	0..65535	Serial number, two older bytes	-
4052	R	0..65535	Serial number, two younger bytes	-
4053	R	0..65535	Program version (*100)	-
4054*	RW	0..65535	Displayed parameters of standard values	0xFFFF
4055*	RW	0..65535	Displayed parameters of average values	0xFFFF

In parenthesis [], suitably is placed: resolution or unit.

* starting from version 1.02

Energy is made available in hundreds of watt-hours (var-hours) in double 16-bit register, and for this reason, one must divide them by 10 when calculating values of particular energy from registers, ie:

Imported active energy = (register 4038 value x 65536 + register 4039 value) /10 [kWh]

Exported active energy = (register 4040 value x 65536 + register 4041 value) /10 [kWh]

Reactive inductive energy = (register 4042 value x 65536 + register 4043 value) /10 [kVarh]

Reactive capacitive energy = (register 4044 value x 65536 + register 4045 value) /10 [kVarh]

Imported active harmonic energy = (register 4046 value x 65536 + register 4047 value) /10 [kWh]

Exported active harmonic energy = (register 4048 value x 65536 + register 4049 value) / 10 [kWh]

Device status register (address 4050, R):

Bit 15 – „1” – damage of the non-volatile memory	Bit 7 – „1” – the interval of averaged power is not elapsed		
Bit 14 – „1” – lack of calibration or erroneous calibration	Bit 6 – „1” – frequency for THD calculation beyond intervals – 48 – 52 for frequency 50 Hz, – 58 – 62 for frequency 60 Hz		
Bit 13 – „1” – error of parameter values	Bit 5 – „1” – voltage too low for frequency measurements		
Bit 12 – „1” – error of energy values	Bit 4 – „1” – too low voltage of phase C		
Bit 11 – „1” – error of phase sequence	Bit 3 – „1” – too low voltage of phase B		
Bit 10 – current range „0” – 1 A~; 1” – 5 A~	Bit 2 – „1” – too low voltage of phase A		
Bit 9	Bit 8	Voltage range	Bit 1 – the RTC time battery is used up
0	0	57.7 V~	Bit 0 – state of relay output „1” – On, „0” - off
0	1	230 V~	

Configuration register of displayed parameters of standard values (address 4054, R/W):

Bit 15 ... 13 – reserved	Bit 6 – „1” – displaying of capacitive passive energy
Bit 12 – „1” – displaying of the date	Bit 5 – „1” – displaying of inductive passive energy
Bit 11 – „1” – displaying of the cosine φ values	Bit 4 – „1” – displaying of exported active energy
Bit 10 – „1” – displaying of active exported harmonic energy/ value of current harmonic	Bit 3 – „1” – displaying of imported active energy
Bit 9 – „1” – displaying of active imported harmonic energy/ value of voltage harmonic	Bit 2 – „1” – displaying of tg
Bit 8 – „1” – displaying of THD current/ value of current harmonic	Bit 1 – „1” – displaying of PF
Bit 7 – „1” – displaying of THD voltage/ value of voltage harmonic	Bit 0 – „1” – displaying of phase-to-phase voltages

Configuration register of displayed parameters of average values (address 4055, R/W):

Bit 15 ... 8 – reserved	Bit 3 – „1” – displaying of averaging active power
Bit 7 – „1” – displaying of consumed ordered power	Bit 2 – „1” – displaying of average tg
Bit 6 – „1” – displaying of frequency	Bit 1 – „1” – displaying of average PF
Bit 5 – „1” – displaying of time	Bit 0 – „1” – displaying of current in neutral wire
Bit 4 – „1” – displaying of average cosine φ	

Table 11

Address of 16-bit registers	Address of 32-bit registers	Operation	Description	Unit
7000	7500	R	Voltage of phase L1	V
7002	7501	R	Current in phase L1	A
7004	7502	R	Active power of phase L1	W
7006	7503	R	Reactive power of phase L1	var
7008	7504	R	Apparent power of phase L1	VA
7010	7505	R	Power factor (PF) of phase L1	-
7012	7506	R	Ratio of reactive power/active power of phase L1	-
7014	7507	R	Voltage of phase L2	V
7016	7508	R	Current in phase L2	A
7018	7509	R	Active power of phase L2	W
7020	7510	R	Reactive power of phase L2	var
7022	7511	R	Apparent power of phase L2	VA
7024	7512	R	Power factor (PF) of phase L2	-
7026	7513	R	Ratio of reactive power/active power of phase L2	-
7028	7514	R	Voltage of phase L3	V
7030	7515	R	Current in phase L3	A
7032	7516	R	Active power of phase L3	W
7034	7517	R	Reactive power of phase L3	var

7036	7518	R	Apparent power of phase L3	VA
7038	7519	R	Power factor (PF) of phase L3	-
7040	7520	R	Ratio of reactive power/active power of phase L3	-
7042	7521	R	Mean 3-phase voltage	V
7044	7522	R	Mean 3-phase current	A
7046	7523	R	3-phase active power	W
7048	7524	R	3-phase reactive power	var
7050	7525	R	3-phase apparent power	VA
7052	7526	R	Mean power factor (PF)	-
7054	7527	R	Mean ratio of reactive power/ active power	-
7056	7528	R	Frequency	Hz
7058	7529	R	Phase-to-phase voltage L ₁₋₂	V
7060	7530	R	Phase-to-phase voltage L ₂₋₃	V
7062	7531	R	Phase-to-phase voltage L ₃₋₁	V
7064	7532	R	Mean phase-to-phase voltage	V
7066	7533	R	3-phase 15, 30, 60 minutes' active Power (P1 + P2 + P3)	W
7068	7534	R	Harmonic U1 / THD U1	V / %
7070	7535	R	Harmonic U2 / THD U2	V / %
7072	7536	R	Harmonic U3 / THD U3	V / %
7074	7537	R	Harmonic I1 / THD I1	A / %
7076	7538	R	Harmonic I2 / THD I2	A / %
7078	7539	R	Harmonic I3 / THD I3	A / %
7080	7540	R	Cosinus of angle between U1 and I1	-
7082	7541	R	Cosinus of angle between U2 and I2	-
7084	7542	R	Cosinus of angle between U3 and I3	-
7086	7543	R	3-phase mean cosinus	-
7088	7544	R	Angle between U1 and I1	°
7090	7545	R	Angle between U2 i I2	°
7092	7546	R	Angle between U3 i I3	°
7094	7547	R	Current in neutral wire (calculated from vectors)	A
7096	7548	R	Imported 3-phase active energy (number of overflows in register 7549, reset after exceeding 99999999.9 kWh)	100 MWh
7098	7549	R	Imported 3-phase active energy (counter totting up to 99999.9 kWh)	kWh
7100	7550	R	Exported 3-phase active energy (number of overflows in register 7551, reset after exceeding 99999999.9 kWh)	100 MWh
7102	7551	R	Exported 3-phase active energy (counter totting up to 99999.9 kWh)	kWh
7104	7552	R	3-phase reactive inductive energy (number of overflows in register 7553, reset after exceeding 99999999.9 kVarh)	100 Mvarh
7106	7553	R	3-phase reactive inductive energy (counter totting up to 99999.9 kVarh)	kvarh
7108	7554	R	3-phase reactive capacitive energy (number of overflows in register 7555, reset after exceeding 99999999.9 kVarh)	100 Mvarh
7110	7555	R	3-phase reactive capacitive energy (counter totting up to 99999.9 kVarh)	kvarh
7112	7556	R	Imported 3-phase active harmonic energy (number of overflows in register 7557, reset after exceeding 99999999.9 kWh)	100 MWh
7114	7557	R	Imported 3-phase active harmonic energy (counter totting up to 99999.9 kWh)	kWh
7116	7558	R	Exported 3-phase active harmonic energy (number of overflows in register 7559, reset after exceeding 99999999.9 kWh)	100 MWh
7118	7559	R	Exported 3-phase active harmonic energy (counter totting up to 99999.9 kWh)	kWh
7120	7560	R	Time – hours, minutes	-
7122	7561	R	Time – month, day	-
7124	7562	R	Time – year	-



7126	7563	R	Analog output control	Ma
7128	7564	R	Voltage L1 min	V
7130	7565	R	Voltage L1 max	V
7132	7566	R	Voltage L2 min	V
7134	7567	R	Voltage L2 max	V
7136	7568	R	Voltage L3 min	V
7138	7569	R	Voltage L3 max	V
7140	7570	R	Current L1 min	A
7142	7571	R	Current L1 max	A
7144	7572	R	Current L2 min	A
7146	7573	R	Current L2 max	A
7148	7574	R	Current L3 min	A
7150	7575	R	Current L3 max	A
7152	7576	R	Active power L1 min	W
7154	7577	R	Active power L1 max	W
7156	7578	R	Active power L2 min	W
7158	7579	R	Active power L2 max	W
7160	7580	R	Active power L3 min	W
7162	7581	R	Active power L3 max	W
7164	7582	R	Reactive power L1 min	var
7166	7583	R	Reactive power L1 max	var
7168	7584	R	Reactive power L2 min	var
7170	7585	R	Reactive power L2 max	var
7172	7586	R	Reactive power L3 min	var
7174	7587	R	Reactive power L3 max	var
7176	7588	R	Apparent power L1 min	VA
7178	7589	R	Apparent power L1 max	VA
7180	7590	R	Apparent power L2 min	VA
7182	7591	R	Apparent power L2 max	VA
7184	7592	R	Apparent power L3 min	VA
7186	7593	R	Apparent power L3 max	VA
7188	7594	R	Power factor (PF) L1 min	-
7190	7595	R	Power factor (PF) L1 max	-
7192	7596	R	Power factor (PF) L2 min	-
7194	7597	R	Power factor (PF) L2 max	-
7196	7598	R	Power factor (PF) L3 min	-
7198	7599	R	Power factor (PF) L3 max	-
7200	7600	R	Ratio of reactive/active power L1 min	-
7202	7601	R	Ratio of reactive/active power L1 max	-
7204	7602	R	Ratio of reactive/active power L2 min	-
7206	7603	R	Ratio of reactive/active power L2 max	-
7208	7604	R	Ratio of reactive /active power L3 min	-
7210	7605	R	Ratio of reactive/active power L3 max	-
7212	7606	R	Phase-to-phase voltage L _{1,2} min	V
7214	7607	R	Phase-to-phase voltage L _{1,2} max	V
7216	7608	R	Phase-to-phase voltage L _{2,3} min	V
7218	7609	R	Phase-to-phase voltage L _{2,3} max	V
7220	7610	R	Phase-to-phase voltage L _{3,1} min	V
7222	7611	R	Phase-to-phase voltage L _{3,1} max	V
7224	7612	R	Mean 3-phase voltage min	V
7226	7613	R	Mean 3-phase voltage max	V
7228	7614	R	Mean 3-phase current min	A
7230	7615	R	Mean 3-phase current max	A
7232	7616	R	3-phase active power min	W
7234	7617	R	3-phase active power max	W
7236	7618	R	3-phase reactive power min	var
7238	7619	R	3-phase reactive power max	var
7240	7620	R	3-phase apparent power min	VA
7242	7621	R	3-phase apparent power max	VA

7244	7622	R	Power factor (PF) min	-
7246	7623	R	Power factor (PF) max	-
7248	7624	R	Ratio of mean 3-phase reactive/active power min	-
7250	7625	R	Ratio of mean 3-phase reactive/active power max	-
7252	7626	R	Frequency min	Hz
7254	7627	R	Frequency max	Hz
7256	7628	R	Mean phase-to-phase voltage min	V
7258	7629	R	Mean phase-to-phase voltage max	V
7260	7630	R	Mean active power min	W
7262	7631	R	Mean reactive power max	W
7264	7632	R	Harmonic U1 / THD U1 min	V / %
7266	7633	R	Harmonic U1 / THD U1 max	V / %
7268	7634	R	Harmonic U2 / THD U2 min	V / %
7270	7635	R	Harmonic U2 / THD U2 max	V / %
7272	7636	R	Harmonic U3 / THD U3 min	V / %
7274	7637	R	Harmonic U3 / THD U3 max	V / %
7276	7638	R	Harmonic I1 / THD I1 min	A / %
7278	7639	R	Harmonic I1 / THD I1 max	A / %
7280	7640	R	Harmonic I2 / THD I2 min	A / %
7282	7641	R	Harmonic I2 / THD I2 max	A / %
7284	7642	R	Harmonic I3 / THD I3 min	A / %
7286	7643	R	Harmonic I3 / THD I3 max	A / %
7288	7644	R	Cosinus of angle between U1 i I1 min	-
7290	7645	R	Cosinus of angle between U1 i I1 max	-
7292	7646	R	Cosinus of angle between U2 i I2 min	-
7294	7647	R	Cosinus of angle between U2 i I2 max	-
7296	7648	R	Cosinus of angle between U3 i I3 min	-
7298	7649	R	Cosinus of angle between U3 i I3 max	-
7300	7650	R	Mean 3-phase cos min	-
7302	7651	R	Mean 3-phase cos max	-
7304	7652	R	Angle between U1 i I1 min	°
7306	7653	R	Angle between U1 i I1 max	°
7308	7654	R	Angle between U2 i I2 min	°
7310	7655	R	Angle between U2 i I2 max	°
7312	7656	R	Angle between U3 i I3 min	°
7314	7657	R	Angle between U3 i I3 max	°
7316	7658	R	Current in neutral wire min	A
7318	7659	R	Current in neutral wire max	A
7800	7660	R	U1 – harmonic 2	%
...
7838	7679	R	U1 - harmonic 21	%
7840	7680	R	U2 - harmonic 2	%
...
7878	7699	R	U2 - harmonic 21	%
7880	7700	R	U3 - harmonic 2	%
...
7918	7719	R	U3 - harmonic 21	%
7920	7720	R	I1 - harmonic 2	%
...
7958	7739	R	I1 - harmonic 21	%
7960	7740	R	I2 – harmonic 2	%
...
7998	7759	R	I2 - harmonic 21	%
8000	7760	R	I3 - harmonic 2	%
...
8038	7779	R	I3 - harmonic 21	%
8040	7780	R	Consumed ordered power	%

In case of a lower exceeding the value -1e20 is written in, however after an upper exceeding or error occurrence, the value 1e20 is written.

8. ERROR CODES

During the meter operation, messages about errors can occur. Reasons of errors are presented below.

- **Err1** – when the voltage or current is too small when measuring:
 - P_{fi} , $\text{tg}\varphi_i$, \cos , THD, harmonic below 10% U_n ,
 - P_{fi} , $\text{tg}\varphi_i$, \cos , below 1% I_n ,
 - THD, harmonic below 10% I_n ,
 - f below 10% U_n ,
 - $I_{(n)}$, below 10% I_n ;
- **bAd Freq** – When measuring harmonics and THD, if the frequency value is beyond the interval 48 – 52 Hz for 50Hz i 58 – 62 for 60 Hz;
- **Err bat** – is displayed when the battery of the internal RTC clock is used up. The measurement is carried out after switching the supply on and every day at midnight.
One can disable the message by the  push-button. The disabled message remains inactive till the renewed switching of the meter on.
- **Err CAL, Err EE** – are displayed when the meter memory is damaged. The meter must be sent to the manufacturer.
- **Err PAr** – are displayed when operating parameters in the meter are incorrect. One must restore manufacturer's parameters (from the menu level or through RS-485).
One can disable the message by the  push-button.
- **Err Enrg** – are displayed when energy values in the meter are incorrect.
One can disable the message by the  push-button. Incorrect energy values are reset.
- **Err L2 L3** – error of phase sequence, one must interchange the connection of phase 2 and phase 3
- or ----- - lower overflow. The measured value is smaller than the lower measuring quantity range
- or ----- - upper overflow. The measured value is higher than the upper measuring quantity range or measurement error.

9. TECHNICAL DATA

Measuring ranges and admissible basic errors

Table 12

Measured value	Indication range*	Measuring range	L1	L2	L3	Σ	Basic error
Current 1/5A L1..L3	0.00 .. 60 kA	0.02 .. 6 A~	•	•	•		± 0.2%
Voltage L-N	0.0 .. 1.04 MV	2.9 .. 276 V~	•	•	•		± 0.2%
Voltage L-L	0.0 .. 1.92 MV	10 .. 480 V~	•	•	•		± 0.5%
Frequency	47.0 .. 63.0 Hz	47.0 .. 63.0 Hz	•	•	•		± 0.2%
Active power	-9999 MW ..0.00 W .. 9999 MW	-1.65 kW ..1.4 W .. 1.65 kW	•	•	•	•	± 0.5%
Reactive power	-9999 Mvar ..0.00 var .. 9999 Mvar	-1.65 kvar ..1.4 var .. 1.65 kvar	•	•	•	•	± 0.5%
Apparent power	0.00 VA .. 9999 MVA	1.4 VA .. 1.65 kVA	•	•	•	•	± 0.5%
Power factor PF	-1 .. 0 .. 1	-1 .. 0 .. 1	•	•	•	•	± 2%
Tangent φ	-1.2 .. 0 .. 1.2	-1.2 .. 0 .. 1.2	•	•	•	•	± 2%
Cosinus φ	-1 ... 1	-1 ... 1	•	•	•	•	± 1%
φ	-180 ... 180	-180 ... 180	•	•	•		± 0.5%
Imported active energy	0 ..99 999 999,9 kWh					•	± 0.5%
Exported active energy	0 ..99 999 999,9 kWh					•	± 0.5%
Reactive inductive energy	0 ..99 999 999,9 kVarh					•	± 0.5 %
Reactive capacitive energy	0 ..99 999 999,9 kVarh					•	± 0.5%
THD	0...400%	0...400%	•	•	•		± 5%

* Depending on the set tr_U ratio (ratio of the voltage transformer: 0.1...4000.0)
and tr_I ratio (ratio of the current transformer: 1...10000)

Caution! For the correct current measurement the presence of a voltage higher than 0.05 Un is required at least in one of the phase.

Power input:

- in supply circuit ≤ 6 VA
- in voltage circuit ≤ 0.05 VA
- in current circuit ≤ 0.05 VA

Display field

dedicated display LCD 3.5",

Relay output

relay, voltageless NO contacts

load capacity: 250 V~/ 0.5 A~ (AC1)

Analog output

current 0(4)...20...24 mA

load resistance ≤ 250 Ω

resolution 0.01 % of the range

	basic error 0.2%
Serial interface RS-485:	address: 1..247 mode: 8N2, 8E1, 8O1,8N1 baud rate: 4.8, 9.6, 19.2, 38,4 kbit/s transmission protocol: Modbus RTU response time: 600 ms (requests about archive)
Energy impulse output	output of O/C type (NPN), passive of class A acc.to EN 62053-31; supply voltage 18...27V, current 10...27mA
Constant of O/C type output impulse	5000 - 20000 imp./kWh independently of set tr_U, tr_I ratios
Protection grade ensured by the casing	
from frontal side	IP 65
from terminal side	IP 20
Weight	0.3 kg
Overall dimensions	96 x 96 x 77 mm
Reference and rated operating conditions	
- supply voltage	85...253 V d.c or a.c. (40...400 Hz) 20...40 V d.c. or a.c. (40...400 Hz)
- input signal:	0 .. $0.005..1.2I_n$; $0.05..1.2U_n$ for current, voltage 0 .. $0.1..1.2I_n$; $0..0.1..1.2U_n$; for power factors Pf_i , $t\phi_i$ frequency <u>45..63</u> Hz; sinusoidal (THD \leq 8%)
- power factor	-1...0...1
- ambient temperature	-25.. <u>23</u> ..+55 °C
- storage temperature	-30.. <u>70</u> °C
- relative humidity	25 ... 95 % (condensation inadmissible)
- admissible peak factor :	
- current intensity	2
- voltage	2
- external magnetic field	<u>0...40</u> ...400 A/m
- short duration overload (5 s)	
- voltage inputs	2 U_n (max.1000 V)
- current inputs	10 I_n
- operating position	any
- preheating time	5 min.
Battery of the real time clock:	CR2032

Additional errors:

in % of the basic error

- from frequency of input signals < 50%
- from ambient temperature changes < 50%/10 °C
- for THD > 8% < 100%

Standards fulfilled by the meter:**Electromagnetic compatibility:**

- noise immunity acc. to EN 61000-6-2
- noise emissions acc. to EN 61000-6-4

Safety requirements:

according to EN 61010 -1 standard

- isolation between circuits: basic
- installation category: III
- pollution level: 2
- maximum phase-to-earth voltage:
 - for supply and measuring circuits 300 V
 - for remaining circuits 50 V
- altitude above sea level: < 2000 m

10. ORDERING CODES

Table 13

Meter of network parameters ND20	X	X	X	X	XX	X	X
Current input In:							
1 A (X/1)	1						
5 A (X/5)	2						
Voltage input (phase/phase-to-phase) Un:							
3 x 57.7/100 V		1					
3 x 230/400 V		2					
Analog current output:							
without analog output			0				
with programmable output: 0(4)...20 mA			1				
Supply voltage:							
85...253 V d.c. or a.c. (40...400 Hz)				1			
20...40 V d.c. or a.c. (40...400 Hz)				2			
Kind of version:							
standard					00		
custom-made*					XX		
Language:							
Polish						P	
English						E	
other						X	
Acceptance tests:							
without extra quality requirements							0
with an extra quality inspection certificate							1
acc. to customer's requirements*							X

*After agreeing with the manufacturer.

Example of Order:

When ordering please respect successive code numbers.

The code: **ND20- 2-2-1-1- 00- E-1** means:

ND20 – meter of network parameters of ND20 type

2 – current input In : 5 A (x/5),

2 -- input voltage (phase/phase-to-phase) Un = 3 x 230/400 V,

1 – with programmable analog output,

1 – supply voltage: 85...253 V a.c./d.c.,

00 – standard version

E – all descriptions and user's manual in English,

1 – with an extra quality inspection certificate.

11. MAINTENANCE AND GUARANTEE

The ND20 meter does not require any periodical maintenance.

In case of some incorrect operations:

After the dispatch date and in the period stated in the guarantee card:

One should return the instrument to the Manufacturer's Quality Inspection Dept.

If the instrument has been used in compliance with the instructions, we guarantee to repair it free of charge.

The disassembling of the housing causes the cancellation of the granted guarantee.

After the guarantee period:

One should turn over the instrument to repair it in a certified service workshop.

Our policy is one of continuous improvement and we reserve the right to make changes in design and specifications of any products as engineering advances or necessity requires and to revise the above specifications without notice.

CONTROL MEASUREMENT RECORDING

SALES PROGRAM

- Digital and Bargraph Panel Meters
- Measuring Transducers
- Analog Panel Meters (DIN Instruments)
- Industrial Process and Power Controllers
- Pen, Dot and Paperless Recorders
- Analysers for Measurement of Network Parameters
- Electronic 1-phase and 3-phase Watt-hour Meters
- Large Size Display Panels
- Elements of Integration Systems
- Accessories for Measuring Instruments (Shunts)
- Measuring Systems (Energy, Heat, Control)
- Custom-made Products According to Customer's Requirements

We also offer our services in the production of:

- Aluminium Alloy Pressure Castings
- Precision Engineering and Thermoplastics Parts
- Subcontracting of Electronic Devices (SMT)
- Pressure Castings and Other Tools

Quality Procedures: According to ISO 9001 and ISO 14001 international requirements.

All our instruments have CE mark .
For more information, please write to or phone our Export Department

ND20- 09A/1



Lubuskie Zakłady Aparatów Elektrycznych - LUMEL S.A.

ul. Sulechowska 1
65-022 Zielona Góra – Poland

Tel.: (48-68) 32 95 1 00 (exchange)

Fax: (48-68) 32 95 1 01

e-mail:lumel@lumel.com.pl

<http://www.lumel.com.pl>

Export Department:

Tel.: (48-68) 329 53 02

Fax: (48-68) 325 40 91

export@lumel.com.pl