



# DIGITAL PANEL METER N300 TYPE



**USER'S MANUAL**





# Contents

---

1. APPLICATION AND METER DESIGN .....	5
2. METER SET .....	6
3. BASIC REQUIREMENTS, OPERATIONAL SAFETY .....	7
4. INSTALLATION .....	8
5. SERVICE .....	12
6. RS-485 INTERFACE .....	34
7. ERROR CODES .....	48
8. TECHNICAL DATA .....	49
9. ORDER CODES .....	52
10. MAINTENANCE AND GUARANTEE .....	54



# 1. APPLICATION AND METER DESIGN

---

The N300 meter is a programmable digital panel meter destined for measurements: number of pulses, frequency, period, worktime, encoder position. Additionally, the meter enables the indication of the current time. The readout field is a LED display, which allows the exposition in colours: red, green and orange. The measured input signal can be arbitrary converted by means of a 21-point individual characteristic.

## **Features of the N300 Meter:**

- display colour individually programmed in three ranges,
- programmable thresholds of displayed overflows,
- 2 NOC relay alarms operating in 6 modes,
- 2 switched relay alarms with a switching contact operating in 6 modes (option),
- signaling of measuring range overflow,
- automatic setting of the decimal point,
- programming of alarms and analog outputs with the reaction on the selected input quantity (main or auxiliary input),
- additional counter input,
- control inputs of the main input work, additional or both simultaneously,
- signaling of additional input state,
- possible control of counter operation by means of the meter keyboard,
- automatic reset of counters at the set point value
- real-time clock with the function of the clock supply support in case of the meter supply decay,
- programmed averaging time – function of walking window with the averaging time up to 1 hour,
- monitoring of set parameter values,
- locking of introduced parameters by means of a password,
- recount of the measured quantity on the base of the 21-point individual characteristic,

- service of the interface with MODBUS protocol in the RTU mode (option),
- conversion of the measured value into a standard – programmable current or voltage signal (option),
- highlight of any measuring unit acc. to the order.
- signaling of alarm operation – switching the alarm on causes the highlight of the output number,
- galvanic separation of pulse inputs between them,
- galvanic separation between terminals: alarm, supply, input, analog, output of auxiliary supply, RS-485 interface.

Protection grade from frontal side: IP65

Meter overall dimensions: 96 x 48 x 93 mm (with terminals).

The meter casing is made of plastic.



*Fig. 1 View of the N300 Digital Meter*

## 2. METER SET

---

The set is composed of:

- N300 meter..... 1 pc
- user's manual..... 1 pc
- guarantee card ..... 1 pc
- set of clamps to fix in the panel ..... 4 pcs
- seal..... 1 pc

When unpacking the meter, please check whether the type and option code on the data plate correspond to the order.

### 3. BASIC REQUIREMENTS, OPERATIONAL SAFETY

---

In the safety service scope, the N300 meter meets the requirements of the EN 61010-1 standard.

Mentioned below applied symbols mean:



- especially important, one must acquaint with this information before connecting the meter. The non-observance of notices marked by this symbol can occasion injuries of the personnel and a damage of the instrument.



- one must take note of this when the instrument is working inconsistently to the expectations. Possible consequences if disregarded.

#### **Observations concerning the operational safety**

- All operations concerning transport, installation, and commissioning as well as maintenance, must be carried out by qualified, skilled personnel, and national regulations for the prevention of accidents must be observed.
- Before switching the meter on, one must check the correctness of connections.
- Do not connect the meter to the network through an autotransformer.
- Before removing the meter housing, one must switch the supply off and disconnect measuring circuits.
- The meter is designed to be installed and exploited in electromagnetic industrial environment conditions.
- When connecting the supply, one must remember that a switch or a circuit-breaker should be installed in the building. This switch should be located near the device, easy accessible by the operator, and suitably marked as an element switching the meter off.
- Non-authorized removal of the housing, inappropriate use, incorrect installation or operation, creates the risk of injury to personnel or meter damage.

For more detailed information, please study the User's Manual.

## 4. INSTALLATION

The meter has separable strips with screw terminals, what enables the connection of external wires of  $1.5 \text{ mm}^2$  cross-section for input signals and  $2.5 \text{ mm}^2$  for other signals.

One must prepare a hole of  $92^{+0.6} \times 45^{+0.6} \text{ mm}$  in the panel, which the thickness should not exceed 6 mm.

The meter must be introduced from the panel front with disconnected supply voltage. Before the insertion into the panel, one must check the correct placement of the seal. After the insertion into the hole, fix the meter by means of clamps (fig. 2).

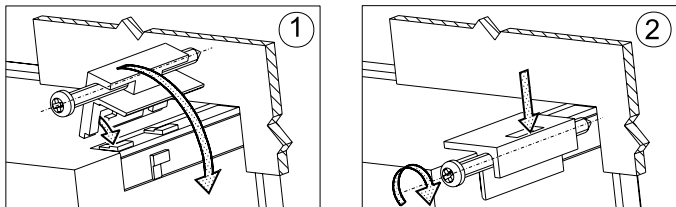

Fig. 2. Meter Fixing

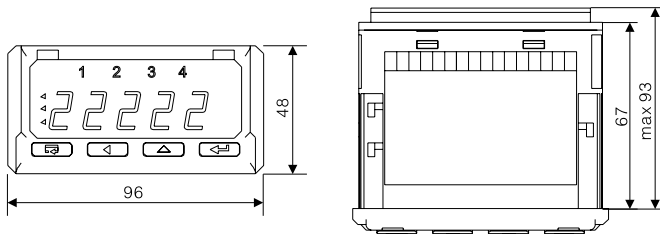

Fig. 3. Overall Dimensions

## 4.1. Lead-out of Signals

Signals led out on the meter connectors are presented on the fig. 4. All input signals are separated between them and separated from other circuits. Circuits of successive groups of signals are separated between them.

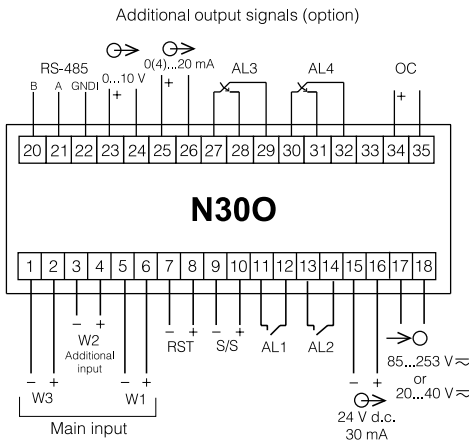

Fig. 4. Description of Signals on Connection Strips

Clamps	Description	Clamps	Description
1-2	W3- Main input. Counting of pulses downwards.	11-12	alarm output 1, relay
3-4	W2 - Additional input. Auxiliary counter.	13-14	alarm output 2, relay
5-6	W1- Main input. Counting of pulses upwards.	15-16	24 V external transducer supply output
7-8	RST- Reset input (reset) of the main counter or/and auxiliary counter. The function is available after switching in the meter menu on.	17-18	supply
9-10	S/S – start/stop of counting. The function is available after switching in the meter menu on.	20-21-22	RS-485 output
		23-24	analog output 1, voltage
		25-26	analog output 1, current
		27-28-29	alarm output 3, relay
		30-31-32	alarm output 4, relay
		34-35	OC – open collector output of npn type– signaling of the range overflow.

## 4.2. Examples of Connections

An example of a N300 meter and a inductive PCID transducer connection with an output of NPN and PNP type is presented on the fig. 5. The way to connect a transducer with an output of contactron/relay type is presented on the fig. 6. In examples, the connection of the main input W1 is shown. Other inputs are connected in the same way but we must remember, that all inputs are galvanically separated between them and have a system limiting the input current. The range of voltages controlling the input should be in the 5..24 V d.c. range.

a)

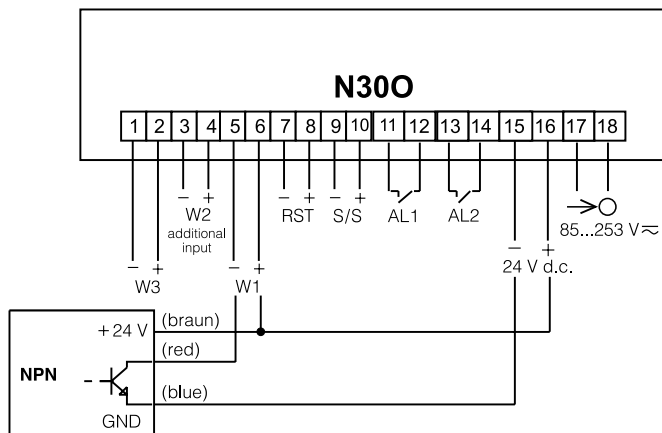

b)

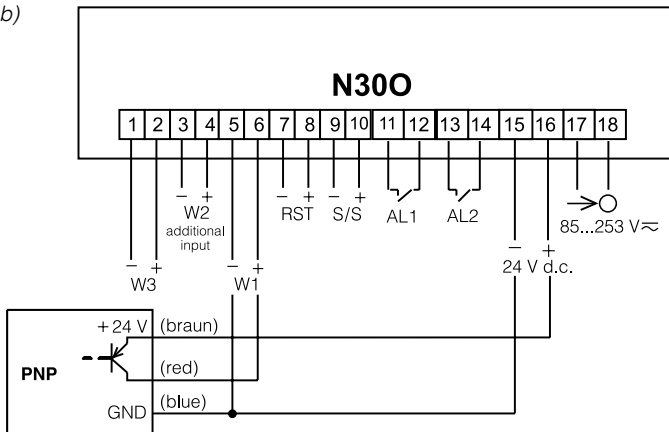

Fig. 5. Connection of the Transducer with the OC Output:  
a) NPN Type b) PNP Type.

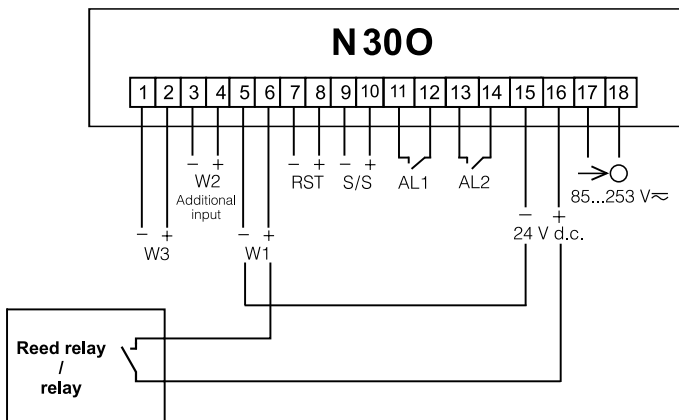

Fig. 6. Connection of the Transducer with the Reed Relay/ Relay Output Type

## 5. SERVICE

---

### 5.1. Display Description

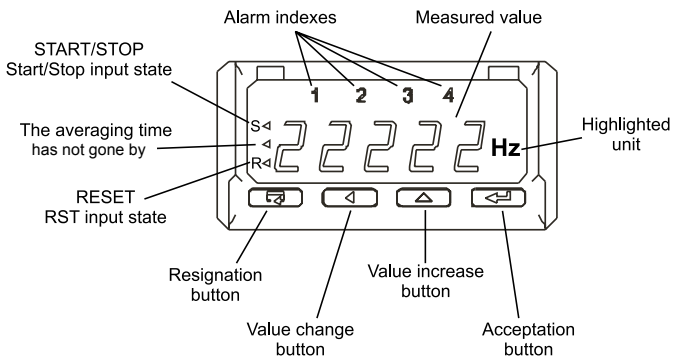

Fig. 7. Description of the Meter Frontal Plate

### 5.2. Messages after Switching the Supply on

After switching the supply on, the meter displays the meter name N300 and next, the program version in the shape „ x.xx” – where x.xx is the number of the current program version or the number of a custom-made option. Next, the meter carries out measurements and displays the value of the input signal. The meter sets up automatically the decimal point position when displaying the value. The format (number of places after the decimal point) can be limited by the user.

### 5.3. Functions of Buttons

 - Acceptation button:

⇒ entry in programming mode (press and hold down ca 3 seconds),

- ⇒ moving through the menu – choice of level,
- ⇒ entry in the mode changing the parameter value,
- ⇒ acceptance of the changed parameter value,
- ⇒ stop the measurement – when holding down the button, the result on the display is not updated.  
The measurement is still carried out.

 - button increasing the value:



- ⇒ display of maximal value, The pressure of the button causes the display of the maximal value during ca 3 seconds. The holding down of the button beyond 3 sec. causes the counting start (for the pulse counter mode and the work-time counter), when the key function is switched on,
- ⇒ entry in the level of the parameter group,
- ⇒ moving through the selected level,
- ⇒ change of the selected parameter value – increasing the value.

 - button changing the digit:



- ⇒ display of minimal value, The pressure of the button causes the display of the minimal value during ca 3 seconds. The holding down of the button beyond 3 sec. causes the counting start (for the pulse counter mode and the work-time counter), when the key function is switched on,
- ⇒ entry in the level of parameter group,
- ⇒ moving through the selected level,
- ⇒ change of selected parameter value – shift on the next digit,



 - resignation button:





- ⇒ entry in the menu monitoring the meter parameters (by holding down ca 3 seconds),
- ⇒ exit from the menu monitoring meter parameters,
- ⇒ resignation of the parameter change,
- ⇒ absolute exit from the programming mode (holding down ca 3 seconds).

The pressure of the   button combination and holding them down ca 3 seconds causes the erasing of alarm signaling. This operation acts only when the support function is switched on.

The pressure of the   button combination causes the erasing of the minimal value.

The pressure of the   button combination causes the erasing of the maximal value.

The pressure of the   button combination causes the display of the second counter contents. A longer holding down (upper than 3 seconds) causes the reset of the main counter (if the service of counters from the keyboard is switched on). The auxiliary counter is reset only from the **Inp2** counter.

The pressure and holding down the  button during 3 seconds causes the entry to the menu monitoring meter parameters. One must move through the monitoring menu by means of  and  buttons. In this menu, all programmable meter parameters are only available for readout. In this mode, the menu **Ser** is not available. The exit from the monitoring menu is carried out by means of the  button. In the monitoring menu, parameter symbols are displayed alternately with their values.

The service algorithm of the meter is presented on the fig. 8.

## 5.4. Programming

The pressure of the  button and holding it down through ca 3 seconds causes the entry in the programming matrix. If the entry is protected by a password, then the safety code symbol **SEC** is displayed alternately with the set up value **0**. The write of the correct code causes the entry in the matrix, the write of an incorrect code causes the display of the **ErCod** symbol. The matrix of transitions into the programming mode is presented on the fig. 9. The selection of the level is made by

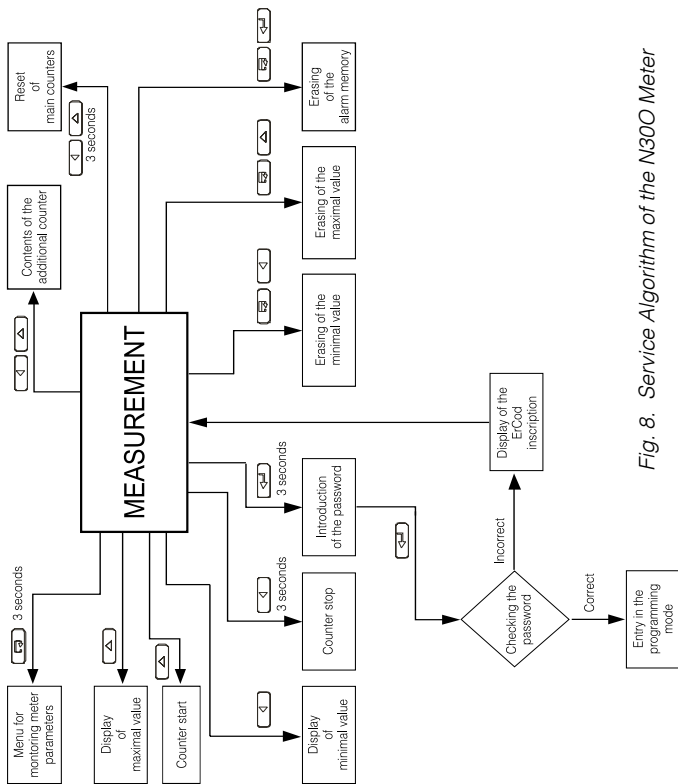









Fig. 8. Service Algorithm of the N300 Meter







<b>6</b>	<b>ALr2</b> Alarm 2	<b>P_A2</b> Type of input quantity for alarm 2	<b>PrL2</b> Lower threshold	<b>PrH2</b> Upper threshold	<b>tYP2</b> Alarm type	<b>dLY2</b> Alarm delay	<b>LED2</b> Signaling support	-----
<b>7</b>	<b>ALr3</b> Alarm 3	<b>P_A3</b> Type of input quantity for alarm 3	<b>PrL3</b> Lower threshold	<b>PrH3</b> Upper threshold	<b>tYP3</b> Alarm type	<b>dLY3</b> Alarm delay	<b>LED3</b> Signaling support	-----
<b>8</b>	<b>ALr4</b> Alarm 4	<b>P_A4</b> Type of input quantity for alarm 4	<b>PrL4</b> Lower threshold	<b>PrH4</b> Upper threshold	<b>tYP4</b> Alarm type	<b>dLY4</b> Alarm delay	<b>LED4</b> Signalling support	-----
<b>9</b>	<b>Out</b> Outputs	<b>P_An</b> Type of quantity for the analog output	<b>Anl</b> Lower threshold for the analog output	<b>AnH</b> Upper threshold for the analog output	<b>typ_A</b> Kind of output (volt/current)	<b>bAud</b> Baud rate	<b>prot</b> Kind of frame	<b>addr</b> Device address
<b>10</b>	<b>SEr</b> Service	<b>Set</b> Write standard parameters	<b>SEC</b> Introduce the password	<b>Hour</b> Setup of the time	<b>unit</b> Highlight the unit	<b>tEST</b> Display test	-----	

Fig. 9. Programming Matrix.

means of the  button, however the entry and moving through the parameters of the chosen level is carried out by means of  and  buttons. Parameter symbols are displayed alternately with their current values. In order to change the value of the selected parameter, one must use the  button. To resign from the change, one must use the  button. In order to exit from the selected level, one must choose the ----- symbol and press the  button. To exit from the programming matrix, one must press the  -button during ca 1 second. Then, the inscription **End** appears for ca 3 seconds and the meter transits to the display of the measured value. In case of leaving the meter in the parameter programming mode, the automatic abandon of the programming mode parameter (parameter, next the menu) follows after 30 seconds and the meter transits to display the measured value.

#### 5.4.1. Value Change Way of the Chosen Parameter



In order to increase the value of the selected parameter, one must press the  button. A single pressure of the button, causes the increase of the value of 1. The increase of value when displaying the digit 9 causes the setting of 0 on this digit. The change of the digit follows after pressing the  button.

In order to accept the set up parameter, one must hold down the  button. Then, the write of the parameter and the display of its symbol follows alternately with the new value. The pressure of the  button during the change of the parameter value will cause the resignation of the write.

#### 5.4.2. Changing Floating-Point Values

The change is carried out in two stages (the transition to the next stage follows after pressing the  button):

- 1) setting the value from the range -19999...99999, similarly as for integral values;

2) setting of the decimal point position (00000., 0000.0, 000.00, 00.000, 0.0000); the  button shifts the decimal point to the left, however the  button shifts the decimal point to the right;

The pressure of the  button during the change of the parameter value will cause the resignation of the write.

Table 1

InP 1		
Parameter symbol	Description	Range of changes
<b>tYP1</b>	Selection of measured value	<b>Cntr</b> – number of pulses <b>FrEqL</b> – frequency for (f < 10 kHz) <b>FrEqH</b> – frequency for (f > 10 kHz) <b>tACH</b> – rotational speed <b>PEr</b> – period <b>PErH</b> – long period > 10 s. <b>CnTH</b> – worktime counter. <b>Hour</b> – current time <b>Enc</b> – incremental encoder
<b>SCAL1</b>	Selection of input quantity rescaling. Measured value is multiplied or divided by the set point value (parameter <b>Cons</b> ).	<b>And</b> – multiplication by the constant <b>diu</b> – division by the constant
<b>ConS1</b>	Constant rescaling the input quantity. The write of a negative value causes the counting down (mode of pulse counter and worktime counter).	<b>-19999...99999</b>
<b>t_L1</b>	Minimal duration time of the lowlevel pulse on the main input. The introduction of the zero value causes the switching of the length control function of the low signal level off. The value is given in milliseconds (concerns only the working mode as a pulse counter).	<b>0...60000</b>

Table 1

	measurement of low frequency, measurement of rotational speed and periods) . For the measurement of frequency and rotational speed, periods, parameters t <sub>L1</sub> and t <sub>H1</sub> define the maximal frequency value. (t <sub>L1</sub> + t <sub>H1</sub> = minimal signal period).	
<b>t<sub>H1</sub></b>	Minimal duration time of the high level pulse on the main input. The introduction of a value lower than 5 causes the switching of the length control function of the high signal level off. The value is given in milliseconds (concerns only working modes as a pulse counter, measurement of low frequency, measurement of rotational speed and periods).For the measurement of frequency, rotational speed and periods , parameters t <sub>L1</sub> and t <sub>H1</sub> define the maximal frequency value.	<b>0...60000</b>
<b>E<sub>In1</sub></b>	Permit for external functions: start/stop, erasing. Taken into consideration only counter modes: pulse counter and worktime counter.	<b>bUt</b> – External function switched off. Access to functions only from the level of meter buttons. <b>In</b> – functions switched off. External functions switched on. Access by means of buttons is switched off. <b>bUtlIn</b> – External functions switched on. Access by means of buttons and additional inputs. Higher priority have external inputs. The option of the counter erasing is available from the keyboard level.
<b>Auto1</b>	The counter is automatically erased after reaching this value. The write of the value 0 switches the function off.	<b>-19999...99999</b>
<b>Cnt1</b>	The measurement time is expressed in seconds. The result on the display presents the mean value counted in the Cnt1 period. This parameter is not taken into consideration during the measurement in counter modes.	<b>1...3600</b>

Table 2

InP 2		
Parameter symbol	Description	Range of changes
<b>Cntr2</b>	Current value of the auxiliary counter	<b>-19999...99999</b>
<b>SCAL2</b>	Choice of rescaling input quantity for the auxiliary input. The measured value is multiplied or divided by the set point value. (parameter <b>ConS2</b> ).	<b>And</b> – multiplication by the constant. <b>diu</b> – division by the constant.
<b>ConS2</b>	Constant rescaling the input quantity. The write of a negative value causes the counting downward.	<b>-19999...99999</b>
<b>t_L2</b>	Minimal duration time of the low level pulse on the auxiliary input. The introduction of a value lower than 5 causes the switching of the length control function of the low signal level off. The value is given in milliseconds	<b>0...60000</b>
<b>t_H2</b>	Minimal duration time of the high level pulse on the auxiliary input. The introduction of the zero value causes the switching of the length control function of the high signal level off. The value is given in milliseconds	<b>0...60000</b>
<b>E_In2</b>	Permit for external functions: start/stop, erasing	<b>On</b> – Control inputs steers the work of the auxiliary counter. <b>Off</b> – Control inputs do not influence the auxiliary counter work.
<b>Auto2</b>	The counter is automatically erased after reaching this value. The write of the value 0 switches the function off.	<b>-19999...99999</b>
<b>CLr2</b>	Erase the counter contents. The choice of the option <b>Y</b> causes the re-write of the value Auto2 to the counter and the transition of the function in the state <b>n</b> .	<b>nO</b> – Do not erase, <b>YeS</b> – Erase the counter,

Table 3

<b>Ind</b>		
<b>Parameter symbol</b>	<b>Description</b>	<b>Range of changes</b>
<b>IndCp</b>	Number of points of the individual characteristic. For a value lower than 2, the individual characteristic is switched off. The number of segments is the number of points reduced of one. In CountH and HoUr modes, the individual characteristic is not taken into consideration.	<b>1...21</b>
<b>Xn</b>	Point value for which we will expect Yn (n-point number)	<b>-19999...99999</b>
<b>Yn</b>	Expected value for Xn.	<b>-19999...99999</b>

Table 4

<b>dISP</b>		
<b>Parameter symbol</b>	<b>Description</b>	<b>Range of changes</b>
<b>d_P</b>	Minimal position of the decimal point when displaying the measured value - display format. This parameter is not taken into consideration during the modes CountH and HoUr.	<b>0.0000 – 0</b> <b>00.000 – 1</b> <b>000.00 – 2</b> <b>0000.0 – 3</b> <b>00000 – 4</b>
<b>CoLdo</b>	Display colour, when the displayed value is over than CoLLo	<b>rEd – red</b> <b>grEEen – green</b> <b>orAnG - orange</b>
<b>CoLbE</b>	Display colour, when the displayed value is higher than CoLLo and lower than CoLHi	
<b>CoLuP</b>	Display colour when the displayed value is higher than CoLHi	
<b>CoLLo</b>	Lower threshold of colour change	<b>-19999..99999</b>
<b>CoLHi</b>	Upper threshold of colour change	<b>-19999..99999</b>



<b>ovrLo</b>	Lower threshold of display narrowing Values below the declared threshold are signaled on the display by the  symbol.	<b>-19999..99999</b>
<b>ovrHi</b>	Upper threshold of display narrowing Values above the declared threshold are signaled on the display by the  symbol.	<b>-19999..99999</b>

Table 5

<b>ALr1, ALr2, ALr3, ALr4</b>		
<b>Parameter symbol</b>	<b>Description</b>	<b>Range of changes</b>
<b>P_A1</b> <b>P_A2</b> <b>P_A3</b> <b>P_A4</b>	Input quantity, steering the alarm.	<b>InP1</b> – Main input (indicated value). <b>InP2</b> – input of the auxillary counter.
<b>PrL1</b> <b>PrL2</b> <b>PrL3</b> <b>PrL4</b>	Alarm lower threshold.	<b>-19999...99999</b>
<b>PrH1</b> <b>PrH2</b> <b>PrH3</b> <b>PrH4</b>	Alarm upper threshold.	<b>-19999...99999</b>

<p><b>tYP1</b> <b>tYP2</b> <b>tYP3</b> <b>tYP4</b></p>	<p>Alarm type. Fig. 12 presents the graphical imaging of alarm types</p>	<p><b>n-on</b> – normal (transition from 0 to 1), <b>n-oFF</b> – normal (transition from 1 to 0), <b>on</b> - switched on, <b>oFF</b> – switched off, <b>H-on</b> – manually switched on; till the change time of the alarm type, the alarm output remains switched on for good <b>H-oFF</b> – manually switched off; till the change time of the alarm type the output alarm remains switched off for good.</p>
<p><b>dLY1</b> <b>dLY2</b> <b>dLY3</b> <b>dLY4</b></p>	<p>Delay of alarm switching.</p>	<p><b>-19999...99999</b></p>
<p><b>LEd1</b> <b>LEd2</b> <b>LEd3</b> <b>LEd4</b></p>	<p>Support of alarm signaling. In the situation when the support function is switched on, after the alarm state retrea, the signaling diode is not blanked. It signals the alarm state till its blanking moment by means of the  push-button combination. This function concerns only and exclusively the alarm signaling, thus relay contacts will operate without support according to the chosen type of alarm.</p>	<p><b>oFF</b> – function switched off <b>on</b> – function switched on</p>

Table 6

<b>out</b>		
<b>Parameter symbol</b>	<b>Description</b>	<b>Range of changes</b>
<b>P_An</b>	Input quantity, on which the analog output has to react.	<b>InP1</b> – main input (indicated value). <b>InP2</b> – input of the auxiliary counter.
<b>AnL</b>	Lower threshold of the analog output. One must give the value, on which we want to obtain the minimal value of signal on the analog output.	<b>-19999...99999</b>
<b>AnH</b>	Upper threshold of the analog output. give the value on which we want to obtain the maximal value of signal on the analog output (10 V or 20 mA).	<b>-19999...99999</b>
<b>tyPA</b>	Type of analog output	<b>0_10U</b> – voltage 0...10 V <b>0_20A</b> – current 0...20 mA <b>4_20A</b> – current 4...20 mA
<b>bAud</b>	Baud rate of the RS-485 interface	<b>4.8</b> – 4800 bit/s <b>9.6</b> – 9600 bit/s <b>19.2</b> – 19200 bit/s <b>38.4</b> – 38400 bit/s <b>57.6</b> – 57600 bit/s <b>115.2</b> – 115200 bit/s
<b>prot</b>	Type of transmission frame of the RS-485 interface.	<b>r8n2</b> <b>r8E1</b> <b>r8o1</b> <b>r8n1</b>
<b>Addr</b>	Address in the MODBUS network. The write of the value 0 switches the interface off.	<b>0...247</b>

Table 7

SEr		
Parameter symbol	Description	Range of changes
<b>SEt</b>	Write in manufacturer's settings. The setup of the value YES causes the write of standard parameters into the meter. Values of manufacturer's parameters are presented in the table 9.	<b>no</b> – do nothing. <b>YeS</b> – causes the write of manufacturer's settings.
<b>SEC</b>	Introduction of a new password. The introduction of the value 0 switches the password off.	<b>0...60000</b>
<b>HOUR</b>	Setting of the current time. The introduction of a wrong time cancels the introduction of time. The introduced value will not taken.	<b>0.00...23.59</b>
<b>unIt</b>	Highlighting of the unit.	<b>On</b> – unit highlighting switched on. <b>Off</b> – unit highlighting switched off.
<b>tESt</b>	Display test. The test consists in a successive lighting up of digital display segments. Alarm diodes and unit backlighting diodes should be lighted.	<b>YeS</b> – causes the test start The pressure of the  button ends the test. <b>no</b> – do nothing.

Table 8

Symbol	Mode Description	Functions of measuring inputs		Measurement of minimal pulse duration time	Automatic cancellation, external functions. Reset from keyboard.	Individual characteristic	Multiplication/division by the constant (SCAL)	Measurement averaging. Walking window	Measurement time of the signal in seconds (AUTO 1)
		W1	W3						
Cntr	Pulse counter	Counting of pulses upwards	Counting of pulses downwards	+	+	+	+	-	-
FrEqL	Measurement of frequency ( $f < 10\text{kHz}$ )	Measuring input	Not used	+	-	+	-	+	+
FrEqH	Measurement of frequency ( $f > 10\text{kHz}$ )	Measuring input	Not used	-	-	+	-	+	-
IACH	Measurement of rotational speed	Measuring input	Not used	+	-	+	+	+	+
PEr	Measurement of period ( $t < 11\text{s}$ )	Measuring input	Not used	+	-	+	-	+	+
PEH	Measurement of period ( $10\text{s} < t < 3600\text{s}$ )	Measuring input	Not used	+	-	+	-	+	+
CntH	Worktime counter	Not used	Not used	-	+	-	-	-	-
HoUr	Current time	Not used	Not used	-	-	-	-	-	-
EnC	Measurement of encoder position	Measuring input	Measuring input	+	+	+	+	-	-

1) The measurement of minimal pulse duration times is when both times  $t_L$  and  $t_H$  are  $\geq 5$  ms

#### 5.4.4 Individual Characteristic

N300 meters can recount the measured value into any value thanks to the implemented individual characteristic function. The individual characteristic rescales the input signal measured according to the set up characteristic. The way of the individual characteristic interaction on the meter operation has been presented on the fig. 10.

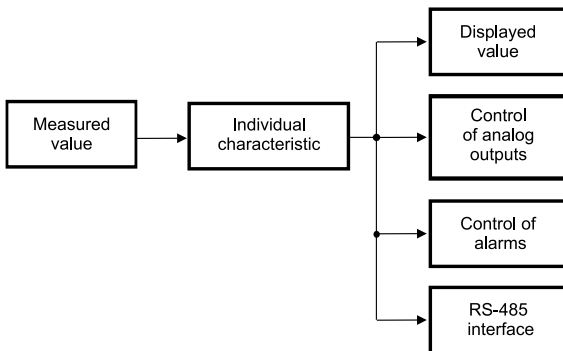
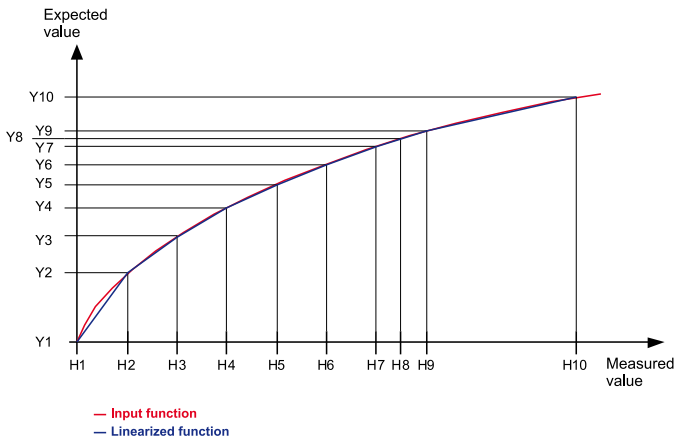

*Fig. 10. Action of the Individual Characteristic*

The user can introduce maximally twenty functions through the given points defining intervals and expected values for successive points.

The programming of the individual characteristic consists in the definition of the number of points which the input function will be linearized by. One must remember, that the number of linearizing functions is of one less than the number of points. Next, one must program successive points by giving the measured value ( $H_i$ ) and the expected value corresponding to it, – value which has to be displayed ( $Y_i$ ) (where  $i$  – number of the successive point,  $0 < i < n$ ).

The graphic interpretation of the individual characteristic is presented on the fig. 11.



*Fig. 11. Individual Characteristic*

During the function approximation, one must remember that for the approximation of functions strongly differing from the linear characteristic, higher the number of linearizing segments, smaller the error related to the linearization.

If measured values are smallest from H1 then, recalculations will be made on the base of the first straight line calculated on the base of points (H1, Y1) and (H2, Y2). However, for values higher than Hn (where  $n < 22$  – the last declared measured value) the value to display will be calculated on the base of the last assigned linear function.

**Note:** All introduced points of the measured value (Hn) must be arranged in the increasing sequence, such to preserve the following dependence:

$$H1 < H2 < H3 \dots < Hn$$

If the above is not fulfilled, the individual characteristic function will be automatically switched off (will not be realized) and a diagnostic flag will be set up in the status register.

### 5.4.5. Alarm Types

The N300 meter is equipped with 2 alarm outputs with NOC contact (make contact) and two alarm outputs with NOC/NCC contact (make and break contact) (option). Each of alarms can work in one of the six modes. The work of alarms in modes is presented in the fig. 12: n-on, n-off, on, off. Two remaining modes: h-on and h-off mean suitably, always switched on and always switched off. These modes are destined for the manually simulation of alarm states.

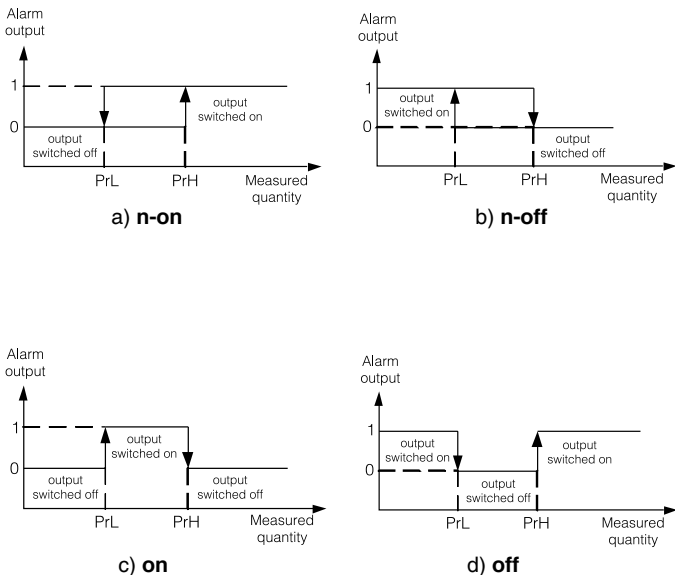

Fig. 12. Alarm types: a) n-on, b) n-off c) on d) off.

## Caution !



- In case of alarms of **n-on, n-off, on, off** types, the write of **PrL > PrH** will cause the alarm switching off.
- In case of a measuring range overflow, the reaction of relays is compatible with written **PrL, PrH, tYP** parameters. In spite of the displayed overflow, the meter still carries out the measurement.
- The meter controls currently the value of the introduced parameter at the moment. In case when the introduced value overflows the upper change range given in the table 1, the meter will make automatically the change into the maximal value. Similarly, in case when the introduced value overflows the lower change range given in the table 1, the meter will make automatically the change into the minimal value.

### 5.4.6 Display Format

The N300 meter adapts automatically the display format (precision) to the value of measured quantity. So that the function could be fully used, one must choose the format **0.0000**, then the meter will display the measured value with the possible highest accuracy. This function does not operate for the time display, where the format is set up automatically. The current time (mode HOUR) is displayed in the 24 hours' format, in the hh.mm shape, where hh – current hour, and mm – current minute. During the worktime measurement (mode CntH) the format is adapted to the measured value. Formats of worktime displays are presented below:

- h.mm.ss – for a number of hours less than 10.
- hhh.mm – for a number of hours higher/equal than 10 and less than 1000.
- hhhhh – for a number of hours higher than 1000.

Where: h – number of hours; m – number of minutes;  
s – number of seconds.

## 5.5. Manufacturer's Parameters

Standard settings of the N300 meter are presented in the table 9. These settings can be restored by means of the meter menu through the choice of the option **Set** from the menu **Ser**.

Table 9

Parameter symbol	Level in matrix	Standard value
tYP1	1	Cntr
SCAL1	1	dlu
ConS1	1	1
t_L1	1	0.1
t_H1	1	0.1
E_In1	1	but
AUto1	1	99999
Cnt1	1	1
Cntr2	2	0
SCAL2	2	dlu
ConS2	2	1
t_L2	2	0.1
t_H2	2	0.1
E_In2	2	OFF
AUto2	2	99999
CLr2	2	no
IndCP	3	no
H0	3	0
Y0	3	0
H1	3	100
Y1	3	100
...	...	...
Hn	3	$(n-1)*100$
Yn	3	$(n-1)*100$
d_P	4	00000

CoLdo	4	grEEEn
CoLbE	4	orAng
CoLuP	4	rEd
CoLLo	4	5000
CoLHi	4	8000
ovrLo	4	-19999
ovrHi	4	99999
P_A1, P_A2, P_A3, P_A4	5, 6, 7, 8	lnP1
tYP1, tYP2, tYP3, tYP4,	5, 6, 7, 8	h-off
PrL1, PrL2, PrL3, PrL4	5, 6, 7, 8	1000
PrH1, PrH2, PrH3, PrH4	5, 6, 7, 8	2000
dLY1, dLY2, dLY3, dLY4	5, 6, 7, 8	0
LEd1, LEd2, LEd3, LEd4	5, 6, 7, 8	oFF
P_An	9	lnP1
tYPA	9	0_10U
AnL	9	0
AnH	9	99999
bAud	9	9.6
prot	9	r8n2
Addr	9	1
SEt	10	no
SEC	10	0
HOUR	10	Not defined
unIt	10	off
tESt	10	off

## 6. INTERFACE RS-485

---

N300 programmable digital meters have serial links in RS-485 standards for the communication in computer systems and with other devices fulfilling Master function. An asynchronous communication character protocol MODBUS has been implemented on the serial link. The transmission protocol describes ways of information between devices through the serial link.

### 6.1. Connection Way of the Serial Interface

The RS-485 standard allows to a direct communication of 32 devices on a single serial link of 1200 m long (at baud rate 9600 b/s). For the connection of a higher quantity of devices, it is necessary to apply additional intermediate-separating systems (e.g. PD51 converter).

The lead of the interface line is presented on the Fig. 4. To obtain a correct transmission, it is necessary to connect lines A and B in parallel with their equivalents in other devices. The connection must be made through a shielded wire. The wire shield must be connected to the protection terminal in the nearest possible proximity of the meter (connect

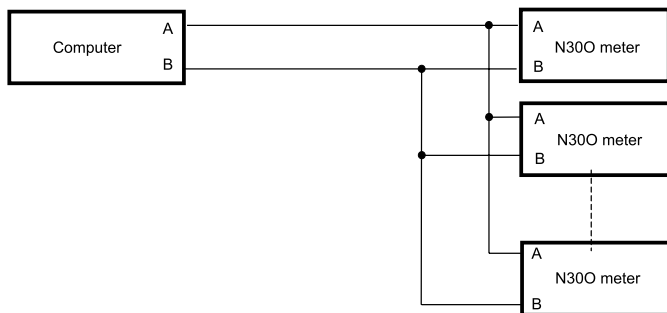

*Fig. 13. Connection Way of the RS-485 Interface*

the shield only to a single point of the protection terminal).

The GND line serves to the additional protection of the interface line at long connections. Then, one must connect GND signals of all devices on the RS-485 bus.

To obtain the connection with the computer, a RS-485 interface card or a suitable converter is indispensable, e.g. PD51 or PD10.

The connection way of devices is shown on the fig. 13.

The designation of transmission lines for the card in the PC computer depends on the card producer.

## 6.2. Description of the MODBUS Protocol Implementation

The implemented protocol is in accordance with the PI-MBUS-300 Rev G of Modicon Company specification.

Set of the serial link parameters of N300 meters in MODBUS protocol:

- meter address 1...247,
- baud rate 4800, 9600, 19200, 38400, 57600, 115200 bit/s,
- work mode RTU with a frame in format 8n2, 8e1, 8o1, 8n1,
- maximal response time 100 ms.

The parameter configuration of the serial link consists in the settlement of the baud rate (**bAUd** parameter), device address (**Addr** parameter), and the format of the information unit (**prot.** parameter)

### Notice:

Each meter connected to the communication network must have:

- unique address, different from addresses of other devices connected to the network,
- identical baud rate and type of information unit.

## 6.3 Description of Applied Functions

Following functions of the MODBUS protocol have been implemented in the N300 meter:

- 03 – Readout of n-registers.
- 16 – Write of n-registers.
- 17 – Identification of the slave device.

## 6.4 Register Map

The register map of the N300 meter is presented below

### **Notice:**

All given addresses are physical addresses. In some computer programs, logic addressing is applied, then addresses must be increased of 1.

Table 10

Range of addresses	Value type	Description
4000-4049	integer (16 bits)	Value placed in a 16-bit register.
7000-7016	float (32 bits)	Value placed in two successive 16-bit registers. Registers include the same data as 32-bit register from the area 7500. Registers are only for readout.
7200-7363	float (32 bits)	Value placed in two successive 16-bit registers. Registers include the same data as 32-bit register from the area 7600. Registers can be read out and written.
7500-7509	float (32 bits)	Value placed in a 32-bit register. Registers are only for readout.
7600-7663	float (32 bits)	Value placed in a 32-bit register. Registers can be read out and written.

## 6.5. Registers for Write and Readout

Table 11

Values placed in 16-bit registers	Symbol	Write (w)/Readout (r)	Range	Description																				
4000	<b>tYP1</b>	w/r	0...7	Input type																				
				<table border="1"> <thead> <tr> <th>Value</th> <th>Description</th> </tr> </thead> <tbody> <tr> <td>0</td> <td>Pulse counter</td> </tr> <tr> <td>1</td> <td>Frequency (f &lt; 10 kHz)</td> </tr> <tr> <td>2</td> <td>Frequency (f &gt; 10 kHz)</td> </tr> <tr> <td>3</td> <td>Rotational speed</td> </tr> <tr> <td>4</td> <td>Period</td> </tr> <tr> <td>5</td> <td>Long period</td> </tr> <tr> <td>6</td> <td>Worktime counter</td> </tr> <tr> <td>7</td> <td>Current time</td> </tr> <tr> <td>8</td> <td>Incremental encoder</td> </tr> </tbody> </table>	Value	Description	0	Pulse counter	1	Frequency (f < 10 kHz)	2	Frequency (f > 10 kHz)	3	Rotational speed	4	Period	5	Long period	6	Worktime counter	7	Current time	8	Incremental encoder
Value	Description																							
0	Pulse counter																							
1	Frequency (f < 10 kHz)																							
2	Frequency (f > 10 kHz)																							
3	Rotational speed																							
4	Period																							
5	Long period																							
6	Worktime counter																							
7	Current time																							
8	Incremental encoder																							
4001	<b>SCAL1</b>	w/r	0, 1	<p>Selection of input quantity recalibration</p> <table border="1"> <thead> <tr> <th>Value</th> <th>Description</th> </tr> </thead> <tbody> <tr> <td>0</td> <td>Multiplication by the constant</td> </tr> <tr> <td>1</td> <td>Division by the constant</td> </tr> </tbody> </table>	Value	Description	0	Multiplication by the constant	1	Division by the constant														
Value	Description																							
0	Multiplication by the constant																							
1	Division by the constant																							
4002	<b>E_In1</b>	w/r	0...2	<p>Permit for external functions Start/Stop. Erasing</p> <table border="1"> <thead> <tr> <th>Value</th> <th>Description</th> </tr> </thead> <tbody> <tr> <td>0</td> <td>External functions switched off. Access to functions from the keyboard level</td> </tr> <tr> <td>1</td> <td>External functions switched on. Access by means of buttons switched off</td> </tr> <tr> <td>2</td> <td>External functions switched on. Access by means of the keyboard and control inputs.</td> </tr> </tbody> </table>	Value	Description	0	External functions switched off. Access to functions from the keyboard level	1	External functions switched on. Access by means of buttons switched off	2	External functions switched on. Access by means of the keyboard and control inputs.												
Value	Description																							
0	External functions switched off. Access to functions from the keyboard level																							
1	External functions switched on. Access by means of buttons switched off																							
2	External functions switched on. Access by means of the keyboard and control inputs.																							
4003	<b>Cnt1</b>	w/r	1...3600	Averaged measurement time expressed in seconds. This time defines the averaging time of the measured value. The displayed value is the mean value calculated from the Cnt1 period.																				

4004	<b>SCAL2</b>	w/r	0, 1	Selection of input quantity recalibration	
				<b>Value</b>	<b>Description</b>
				0	Multiplication by the constant
				1	Division by the constant
4005	<b>E_In2</b>	w/r	0, 1	Permit for external functions	
				<b>Value</b>	<b>Description</b>
				0	External functions control the auxiliary counter work.
				1	External functions does not influence the auxiliary counter work.
4006		w/r		Reserved	
4007	<b>CLr</b>	w/r		Erase the auxiliary counter. The write of the value 2 into the register causes the erasing of the auxiliary counter. The write of the value 1 causes the erasing of the main counter. The write of the value 3 causes the erasing of the main and auxiliary counters.	
4008	<b>IndCp</b>	w/r	1...21	Number of points of the individual characteristic. For the value 1, the individual characteristic is switched off. Segments of the individual characteristic are defined by parameters Xn and Yn, where n – point number.	
4009	<b>d_P</b>	w/r	0...4	Minimal position of the decimal point when displaying the measured value.	
				<b>Value</b>	<b>Description</b>
				0	0.0000
				1	00.000
				2	000.00
				3	0000.0
4	00000				
4010	<b>CoLdo</b>	w/r	0...2	Display colour when the displayed value is lower than <b>coLLo</b>	
				<b>Value</b>	<b>Description</b>
				0	red
				1	green
				2	orange



4018	<b>tyP2</b>	w/r	0...5	Type of alarm 2 (description – fig. 12)	
				<b>Value</b>	<b>Description</b>
				0	n-on
				1	n-off
				2	on
				3	off
				4	h-on
5	h-off				
4019	<b>dLY2</b>	w/r	0...120	Delay of alarm 2 ( in seconds)	
4020	<b>LEd2</b>	w/r	0...1	Support of alarm 2 signaling	
				<b>Value</b>	<b>Description</b>
				0	Support switched off
				1	Support switched on
4021	<b>P_a3</b>	w/r	0, 1	Input quantity controlling the alarm	
				<b>Value</b>	<b>Description</b>
				0	Main input
				1	Auxiliary input
4022	<b>tyP3</b>	w/r	0...5	Type of alarmu 3 (description – fig. 12)	
				<b>Value</b>	<b>Description</b>
				0	n-on
				1	n-off
				2	on
				3	off
				4	h-on
5	h-off				
4023	<b>dLY3</b>	w/r	0...120	Delay of alarm 3 (in seconds)	
4024	<b>LEd3</b>	w/r	0...1	Support of alarm 3 signaling	
				<b>Value</b>	<b>Description</b>
				0	Support switched off
				1	Support switched on
4025	<b>P_a4</b>	w/r	0, 1	Input quantity controlling the alarm	
				<b>Value</b>	<b>Description</b>
				0	Main input
				1	Auxiliary input

4026	<b>tyP4</b>	w/r	0...5	Type of alarm 4 (description – fig. 12)	
				<b>Value</b>	<b>Description</b>
				0	n-on
				1	n-off
				2	on
				3	off
				4	h-on
				5	h-off
4027	<b>dLY4</b>	w/r	0...120	Delay of alarm 4 (in seconds)	
4028	<b>LEd4</b>	w/r	0...1	Support of alarm 4 signaling	
				<b>Value</b>	<b>Description</b>
				0	Support switched off
				1	Support switched on
4029	<b>P_an</b>	w/r	0, 1	Input quantity, which the analog output has to react on.	
				<b>Value</b>	<b>Description</b>
				0	Main input
				1	Auxiliary input
4030	<b>tYPa</b>	w/r	0...2	Type of analog output	
				<b>Value</b>	<b>Description</b>
				0	Voltage input 0...10 V
				1	Current input 0...20 mA
				2	Current input 4...20 mA
4031	<b>bAud</b>	w/r	0...5	Baud rate	
				<b>Value</b>	<b>Description</b>
				0	4800 bit/s
				1	9600 bit/s
				2	19200 bit/s
				3	38400 bit/s
				4	57600 bit/s
				5	115200 bit/s
4032	<b>prot</b>	w/r	0...3	Transmission mode	
				<b>Value</b>	<b>Description</b>
				0	RTU 8N2
				1	RTU 8E1
				2	RTU 8O1
				3	RTU 8N1

4033	<b>Addr</b>	w/r	0...247	Device address. The write of the value 0 causes the interface switching off.	
4034	<b>sAvE</b>	w/r	0...1	Update transmission parameters. Causes the application of introduced RS-485 interface settings.	
4035	<b>SEt</b>	w/r	0...1	Write of standard parameters	
				<b>Value</b>	
				<b>Description</b>	
				0	
				without changes	
				1	
				Setup of standard parameters	
4036	<b>SEc</b>	w/r	0...6000	Password for parameters	
				<b>Value</b>	
				<b>Description</b>	
				0	
				without password	
				...	
				Entry in parameters preceded by a request about the password	
4037	<b>hour</b>	w/r	0...2359	Current time	
				This parameter occurs in the ggmm format, where: gg - means hours, mm – means minutes. The introduction of a wrong hour will cause the setting 23, however the introduction of wrong minutes will generate the setting of the value 59.	
4038	<b>unit</b>	w/r	0, 1	Switching on/off the unit highlight	
				<b>Value</b>	
				<b>Description</b>	
				0	
				Highlight switched off	
				1	
				Highlight switched on	
...	...	...	...	Reserved	
4048	Status1	w/r	0...65535	Meter status. Describes the current state of the meter. Successive bits present the given event. The bit set up on 1 means, that the event took place. Events can be only erased.	
				Bit 15	Break of the supply
				Bit 14	RTC clock. Loss of settings
				Bit 13	Not used
				Bit 12	Lack of communication with data memory
				Bit 11	Wrong settings
				Bit 10	Manufacturer' s settings restored
				Bit 9	Lack of measured values in data memory
				Bit 8	Reset of the auxiliary counter
				Bit 7	Output plate is detected
Bit 6	Output plate – error or lack of calibration				

				Bit 5	Reset of the main counter (the counter has been automatically erased)
				Bit 4	Not used
				Bit 3	Wrong configuration of the individual characteristic.
				Bit 2	Not used
				Bit 1	Not used
				Bit 0	The averaging period Has not elapsed
4049	Status2	w/r		Meter status. Describes the current state of the meter. Successive bits present the given event. The bit set on 1 means, that the event took place. Events can be only erased.	
				Bit 15	Not used
				Bit 14	Not used
				Bit 13	Not used
				Bit 12	Not used
				Bit 11	Not used
				Bit 10	Not used
				Bit 9	Status of the RESET input
				Bit 8	Status of the START / STOP input.
				Bit 7	LED4 – Signaling of alarm No. 4.
				Bit 6	LED3 – Signaling of alarm No. 3.
				Bit 5	LED2 – Signaling of alarm No. 2.
				Bit 4	LED1 – Signaling of alarm No. 1.
				Bit 3	Status of the alarm relay 4.
				Bit 2	Status of the alarm relay 3.
Bit 1	Status of the alarm relay 2.				
Bit 0	Status of the alarm relay 1.				

Table 12

The value is placed in two successive 16-bit registers. These registers include the same data as 32-bit registers from the area 7600	The value is placed in 32-bit registers	Symbol	write (w) / read-out (r)	Range	Description
7200	7600	<b>CoLLo</b>	w/r	-19999...99999	Lower threshold of the display color change
7202	7601	<b>CoLHI</b>	w/r	-19999...99999	Upper threshold of the display color change
7204	7602	<b>ovrLo</b>	w/r	-19999...99999	Lower threshold of the display narrowing
7206	7603	<b>ovrHI</b>	w/r	-19999...99999	Upper threshold of the display narrowing
7208	7604	<b>PRL1</b>	w/r	-19999...99999	Lower threshold of alarm 1
7210	7605	<b>PrH1</b>	w/r	-19999...99999	Upper threshold of alarm 1
7212	7606	<b>PRL2</b>	w/r	-19999...99999	Lower threshold of alarm 2
7214	7607	<b>PrH2</b>	w/r	-19999...99999	Upper threshold of alarm 2
7216	7608	<b>PRL3</b>	w/r	-19999...99999	Lower threshold of alarm 3
7218	7609	<b>PrH3</b>	w/r	-19999...99999	Upper threshold of alarm 3
7220	7610	<b>PRL4</b>	w/r	-19999...99999	Lower threshold of alarm 4
7222	7611	<b>PrH4</b>	w/r	-19999...99999	Upper threshold of alarm 4
7224	7612	<b>AnL</b>	w/r	-19999...99999	Lower threshold of analog output
7226	7613	<b>AnH</b>	w/r	-19999...99999	Upper threshold of analog output
7228	7614	<b>ConS1</b>	w/r	-19999...99999	Constant recalibrating the input quantity on the main input
7230	7615	<b>t_L1</b>	w/r	0...60000	Minimal duration of the low pulse level on the main input
7232	7616	<b>t_H1</b>	w/r	0...60000	Minimal duration of the high pulse level on the main input

7234	7617	<b>Auto1</b>	w/r	-19999...99999	Automatic reset of the main counter Measurement time of the low frequency, speed and periods
7236	7618	<b>Cons2</b>	w/r	-19999...99999	Constant recalibrating the input quantity on the auxiliary input
7238	7619	<b>t_L2</b>	w/r	0...60000	Minimal duration of the low pulse level on the auxiliary input
7240	7620	<b>t_H2</b>	w/r	0...60000	Minimal duration of the high pulse level on the auxiliary input
7242	7621	<b>Auto2</b>	w/r	-19999...99999	Automatic reset of the auxiliary counter
7244	7622	<b>H1</b>	w/r	-19999...99999	Point of the individual characteristic. Point No. 1
7246	7623	<b>Y1</b>	w/r	-19999...99999	Expected value for the point No. 1
7248	7624	<b>H2</b>	w/r	-19999...99999	Point of the individual characteristic. Point No. 2
7250	7625	<b>Y2</b>	w/r	-19999...99999	Expected value for the point No. 2
7252	7626	<b>H3</b>	w/r	-19999...99999	Point of the individual characteristic. Point No. 3
7254	7627	<b>Y3</b>	w/r	-19999...99999	Expected value for the point No. 3
7256	7628	<b>H4</b>	w/r	-19999...99999	Point of the individual characteristic. Point No. 4
7258	7629	<b>Y4</b>	w/r	-19999...99999	Expected value for the point No. 4
7260	7630	<b>H5</b>	w/r	-19999...99999	Point of the individual characteristic. Point No. 5
7262	7631	<b>Y5</b>	w/r	-19999...99999	Expected value for the point No. 5
7264	7632	<b>H6</b>	w/r	-19999...99999	Point of the individual characteristic. Point No. 6
7266	7633	<b>Y6</b>	w/r	-19999...99999	Expected value for the point No. 6
7268	7634	<b>H7</b>	w/r	-19999...99999	Point of the individual characteristic. Point No. 7
7270	7635	<b>Y7</b>	w/r	-19999...99999	Expected value for the point No. 7
7272	7636	<b>H8</b>	w/r	-19999...99999	Point of the individual characteristic. Point No. 8
7274	7637	<b>Y8</b>	w/r	-19999...99999	Expected value for the point No. 8
7276	7638	<b>H9</b>	w/r	-19999...99999	Point of the individual characteristic. Point No. 9
7278	7639	<b>Y9</b>	w/r	-19999...99999	Expected value for the point No. 9
7280	7640	<b>H10</b>	w/r	-19999...99999	Point of the individual characteristic. Point No. 10
7282	7641	<b>Y10</b>	w/r	-19999...99999	Expected value for the point No. 10
7284	7642	<b>H11</b>	w/r	-19999...99999	Point of the individual characteristic. Point No. 11

Table 12

7286	7643	<b>Y11</b>	w/r	-19999...99999	Expected value for the point No. 11
7288	7644	<b>H12</b>	w/r	-19999...99999	Point of the individual characteristic. Point No. 12
7290	7645	<b>Y12</b>	w/r	-19999...99999	Expected value for the point No. 12
7292	7646	<b>H13</b>	w/r	-19999...99999	Point of the individual characteristic. Point No. 13
7294	7647	<b>Y13</b>	w/r	-19999...99999	Expected value for the point No. 13
7296	7648	<b>H14</b>	w/r	-19999...99999	Point of the individual characteristic. Point No. 14
7298	7649	<b>Y14</b>	w/r	-19999...99999	Expected value for the point No. 14
7300	7650	<b>H15</b>	w/r	-19999...99999	Point of the individual characteristic. Point No. 15
7302	7651	<b>Y15</b>	w/r	-19999...99999	Expected value for the point No. 15
7304	7652	<b>H16</b>	w/r	-19999...99999	Point of the individual characteristic. Point No. 16
7306	7653	<b>Y16</b>	w/r	-19999...99999	Expected value for the point No. 16
7308	7654	<b>H17</b>	w/r	-19999...99999	Point of the individual characteristic. Point No. 17
7310	7655	<b>Y17</b>	w/r	-19999...99999	Expected value for the point No. 17
7312	7656	<b>H18</b>	w/r	-19999...99999	Point of the individual characteristic. Point No. 18
7314	7657	<b>Y18</b>	w/r	-19999...99999	Expected value for the point No. 18
7316	7658	<b>H19</b>	w/r	-19999...99999	Point of the individual characteristic. Point No. 19
7318	7659	<b>Y19</b>	w/r	-19999...99999	Expected value for the point No. 19
7320	7660	<b>H20</b>	w/r	-19999...99999	Point of the individual characteristic. Point No. 20
7322	7661	<b>Y20</b>	w/r	-19999...99999	Expected value for the point No. 20
7324	7662	<b>H21</b>	w/r	-19999...99999	Point of the individual characteristic. Point No. 21
7326	7663	<b>Y21</b>	w/r	-19999...99999	Expected value for the point No. 21

## 6.6. Registers only for Readout

Table 13

The value placed in two successive 16-bit registers. These registers include the same data as 32-bit registers from the area 7500	The value is placed in 32-bit registers	Name	Write (w) /readout (r)	Unit	Name of the quantity
7000	7500	Identifier	r	—	Constant identifying the device. The value 181 means the N300 meter
7002	7501	Status	r	—	Status is register describing the current state of the meter
7004	7502	Control	r	%	It is a register defining the steering out of the analog output
7006	7503	Minimum	r	—	Minimal value of the currently displayed value
7008	7504	Maximum	r	—	Maximal value of the currently displayed value
7010	7505	Displayed value	r	—	Currently displayed value
7012	7506	Measured value on the auxiliary input	r	—	Currently measured value on the auxiliary input
7014	7507	Number of pulses counted by the Cnt1 counter	r		Number of pulses counted by the Cnt1 counter without additional calculations
7016	7508	Number of pulses counted by the Cnt2 counter	r	—	Number of pulses counted by the Cnt2 counter without additional calculations



## 7. ERROR CODES

---

After switching the meter on or during the work, messages about errors can appear.

Messages about errors and their reasons are presented below.

Table 14

Error message	Description
	Overflow of upper value of the measuring range value or the programmed indication range
	Overflow of lower value of the measuring range value or the programmed indication range
ErFrt	Communication error with the data memory. One must contact the service workshop.
ErPar	Parameter error. Wrong configuration data. Manufacturer's settings will be restored after pressing any button.
ErDEF	Default settings have been restored. One must press any push-button to transit to a normal work.
ErFPL	Error of measured values stored by the meter (measured value, maximal value, minimal value). One must press any push-button to transit to the normal work. After pressing the push-button, the ErdEF message will be displayed during one second.
ErCAo	Error of analog output calibration. One must press any push-button to transit to the normal mode. Analog outputs will not be serviced. One must contact the Service Department.

## 8. TECHNICAL DATA

---

Measuring Ranges.

Table 15

Kind of inputs	Indication range	Class
Number of pulses Cntr	-19 999..99 999 <sup>1)</sup>	±1 pulse
Frequency <10 kHz	0.05...99 999 Hz <sup>3)</sup>	0.01
Frequency >10 kHz	1...99 999 Hz (measuring range up to 1 MHz) <sup>2)</sup>	0.01
Rotational speed	0.05...99 999 [Rev/min] <sup>1)</sup>	0.01
Period t < 10s	0.0001...11 [s] <sup>1)</sup>	0.01
Period t > 10s	0.0001...3600 [s] <sup>1)</sup>	0.01
Worktime counter	0...99 999 [h]	0.5 sec/24 hours
Current time	00.00...23.59	0.5 sec/24 hours
Encoder	-19 999...99 999	-

1) maximal frequency of input signal 100 kHz.

2) maximal frequency of input signal 1 MHz.

3) maximal frequency of input signal 100 kHz, measuring range 10 Hz.

### Relay outputs

- relays, NOC voltageless contacts  
load capacity 250 V~/0.5A~
- relays, switched voltageless contacts  
load capacity 250 V~/0.5A~

### Analog outputs (option)

- rogrammable, current 0/4..20 mA  
load resistance ≤ 500 Ω
- programmable, voltage 0...10 V  
load resistance ≥ 500 Ω

<b>Output of auxiliary supply</b>	24 V d.c./30 mA
<b>Alarm output OC (option)</b>	output of OC type, passive npn, 30 V d.c./30 mA.
<b>Input signals</b>	voltage 5...36 V d.c., galvanically separated
<b>Duration of control signals</b>	higher than 10 ms
<b>Serial interface</b>	RS-485 (option)
<b>Transmission protocol</b>	MODBUS RTU
<b>Error of analog output</b>	0.2% of the set range
<b>Protection level ensured by the casing:</b>	
- frontal side	IP65
- terminal side	IP10
<b>Weight</b>	< 0.2 kg
<b>Overall dimensions</b>	96 × 48 × 93 mm (with terminals)
<b>Reference Conditions and Rated Operating Conditions:</b>	
- supply voltage	85...253 V d.c./a.c. 40...400 Hz or 20...40 V d.c./a.c. 40...400 Hz
- input signal	5...24 V d.c.
- duration of the control pulse	> 10 ms (shorter pulses are ignored)
- ambient temperature	-25... <u>23</u> ...+55°C
- storage temperature	-33...+70°C
- relative air humidity	25...95% (inadmissible condensation of water vapour)
- work position	any
<b>Additional errors:</b>	
- from temperature changes:	for analog inputs and outputs 50% of the class/10 K

## **Standards fulfilled by the meter:**

### ***Electromagnetic compatibility:***

- noise immunity acc. to EN 61000-6-2
- noise emissions acc. to EN 61000-6-4

### ***Safety requirements:***

acc. to EN61010-1 standard:

- isolation between circuits: basic,
- installation category: III,
- pollution level: 2,
- maximal phase-to-earth work voltage:
  - 300 V for the supply circuit,
  - 50 V for remaining circuits.
- altitude above sea level: < 2000 m.

## 9. ORDER CODES

Table 16

DIGITAL PANEL METER	N300 -	X	X	XX	XX	X	X
<b>Supply voltage:</b>							
85... 253 V a.c. (40...400 Hz) or d.c. ....		1					
20... 40 V a.c. (40...400 Hz) or d.c. ....		2					
<b>Additional outputs:</b>							
lack .....		0					
OC output, RS485, analog outputs .....		1					
OC output, RS485, analog outputs, switched relay outputs .....		2					
<b>Unit:</b>							
unit code number acc. tab. 17 .....				XX			
<b>Version:</b>							
standard .....						00	
custom-made* .....						XX	
<b>Language:</b>							
Polish .....							P
English .....							E
other* .....							X
<b>Acceptance tests:</b>							
without extra quality requirements .....							8
with an extra quality inspection certificate .....							7

\* - after agreeing with the manufacturer.

### ORDER EXAMPLE:

the code: **N300 - 1-0-12-00-E-8** means:

- N300** – programmable digital meter type,
- 1** – supply: 85...253 V a.c/d.c. (40...400 Hz),
- 0** – lack of additional outputs,
- 12** – unit „Mvar” acc. to the table 17,
- 00** – standard version,
- E** – English language,
- 0** – without extra quality requirements.

<b>Code</b>	<b>Unit</b>	<b>Code</b>	<b>Unit</b>
00	Lack of unit	29	%
01	V	30	%RH
02	A	31	pH
03	mV	32	kg
04	kV	33	bar
05	mA	34	m
06	kA	35	l
07	W	36	s
08	kW	37	h
09	MW	38	m <sup>3</sup>
10	var	39	obr
11	kvar	40	szt
12	Mvar	41	imp
13	VA	42	rps
14	kVA	43	m/s
15	MVA	44	l/s
16	kWh	45	obr/min
17	MWh	46	r.p.m.
18	kvarh	47	mm/min
19	Mvarh	48	m/min
20	kVAh	49	l/min
21	MVAh	50	m <sup>3</sup> /min
22	Hz	51	szt/h
23	kHz	52	m/h
24	$\Omega$	53	km/h
25	k $\Omega$	54	m <sup>3</sup> /h
26	°C	55	kg/h
27	°F	56	l/h
28	K	XX	on order <sup>1)</sup>

1) - after agreeing with the manufacturer.

## 10. MAINTENANCE AND GUARANTEE

---

The N300 digital panel meter does not require any periodical maintenance.

In case of some incorrect operations:

### 1. From the Shipping Date, During the Period Given in the Annexed Guarantee Card

One should take the meter down from the installation and return it to the Manufacturer's Quality Control Dept.

If the meter has been used in compliance with the instructions, the Manufacturer warrants to repair it free of charge.

### 2. After the Guarantee Period:

One should turn over the meter to repair it in a certified service workshop.

The disassembling of the casing causes the cancellation of the granted guarantee.

**Our policy is one of continuous improvement and we reserve the right to make changes in design and specifications of any products as engineering advances or necessity requires and revise the above specifications without notice.**



## SALES PROGRAM

- DIGITAL AND BARGRAPH PANEL METERS
- MEASURING TRANSDUCERS
- ANALOG PANEL METERS (DIN INSTRUMENTS)
- ANALOG AND DIGITAL CLAMP-ON METERS
- INDUSTRIAL CONTROLLERS FOR AUTOMATION
- CHART AND PAPERLESS RECORDERS
- POWER CONTROL UNITS AND SOLIDE-STATE RELAYS
- 1-PHASE AND 3-PHASE ELECTRONIC WATT-HOUR METERS
- INTEGRATION ELEMENTS OF MEASURING NETWORKS
- LARGE-SIZE ALPHANUMERICAL DISPLAY PANELS
- ACCESSORIES FOR MEASURING INSTRUMENTS (SHUNTS AND TRANSFORMERS)
- MEASURING SYSTEMS (ENERGY, HEAT, CONTROL)
- CUSTOM-MADE PRODUCTS

### WE ALSO OFFER OUR SERVICES IN THE PRODUCTION OF:

- ALUMINIUM ALLOY PRESSURE CASTINGS
- PRECISION ENGINEERING AND THERMOPLASTICS PARTS
- SMT ASSEMBLY SERVICES
- SUBCONTRACTED ELECTRONIC PRODUCTS

### QUALITY PROCEDURES:

**ACCORDING TO ISO 9001 AND ISO 14001 INTERNATIONAL REQUIREMENTS.**

ALL OUR INSTRUMENTS HAVE CE MARK.

FOR MORE INFORMATION, PLEASE WRITE TO OR PHONE OUR EXPORT DEPARTMENT

N300-07A



**Lubuskie Zakłady Aparatów Elektrycznych LUMEL S.A.**

ul. Sulechowska 1

65-022 Zielona Góra - Poland

Tel.: (48-68) 329 51 00 (exchange)

Fax: (48-68) 329 51 01

e-mail: [lumel@lumel.com.pl](mailto:lumel@lumel.com.pl)

<http://www.lumel.com.pl>

### **Export Department:**

Tel.: (48-68) 329 53 02 or 53 04

Fax: (48-68) 325 40 91

e-mail: [export@lumel.com.pl](mailto:export@lumel.com.pl)