

LUMEL

**PROGRAMMABLE TRANSDUCER
of d.c. CURRENT
and d.c. VOLTAGE
WITH RS-485 INTERFACE**

P12H



45 × 120 × 100 mm

SERVICE MANUAL

CE

CONTENTS

PAGE

1. APPLICATION.....	3
2. SET OF THE P12H TRANSDUCER.....	4
3. BASIC REQUIREMENTS, OPERATIONAL SAFETY.....	5
4. INSTALLATION.....	6
5. SERVICING.....	9
6. RS-485 INTERFACE.....	26
7. TECHNICAL DATA.....	43
8. BEFORE A DAMAGE WILL BE SUBMITTED.....	46
9. EXAMPLES OF P12H TRANSDUCER PROGRAMMINGS.....	48
10. EXECUTION CODES AND ORDERING.....	51
11. MAINTENANCE AND GUARANTEE.....	53

1. APPLICATION

The P12H programmable transducer is intended to the conversion of d.c current and d.c. voltage into a d.c. current or d.c. voltage standard signal. The output signal is galvanically isolated from the input signal and the supply. The read-out field can be an LCD 2 x 8 display (only in P12H-2 execution).

The P12H transducer has an RS-485 interface with MODBUS protocol.

The P12H transducer is programmed by the producer according the ordered execution code but it is possible to change the parameters by the user by means of the keyboard in the P12H-2 execution, through the RS-485 interface or the PD14 programmer.

The PD14¹⁾ programmer is a universal device serving to program all the P11 and P12 families and it must be ordered separately.

P12H transducers realizes following functions:

- conversion of the measured value into any optional output signal on the base of the individual linear characteristic,
- recalculation of the input signal into the indication on the base of the individual multisegment characteristic (maximum 20 segments),
- signalling the set up alarm value overrunnings,
- recording the input signal in programmed time lengths,
- arithmetical functions: raising to a power, extraction of roots, or result inverse,
- programming the indication resolution (only for P12H-2),
- preview of set up parameters values,
- storage of maximal and minimal values,
- programming of the averaging time,
- display of the unit according the table 1,
- handling the RS-485 interface in the MODBUS protocol, both in ASCII either in RTU mode,
- interlocking the parameter introduction by means of a password.

¹⁾ **Note:** The PD14 programmer must be ordered separately.

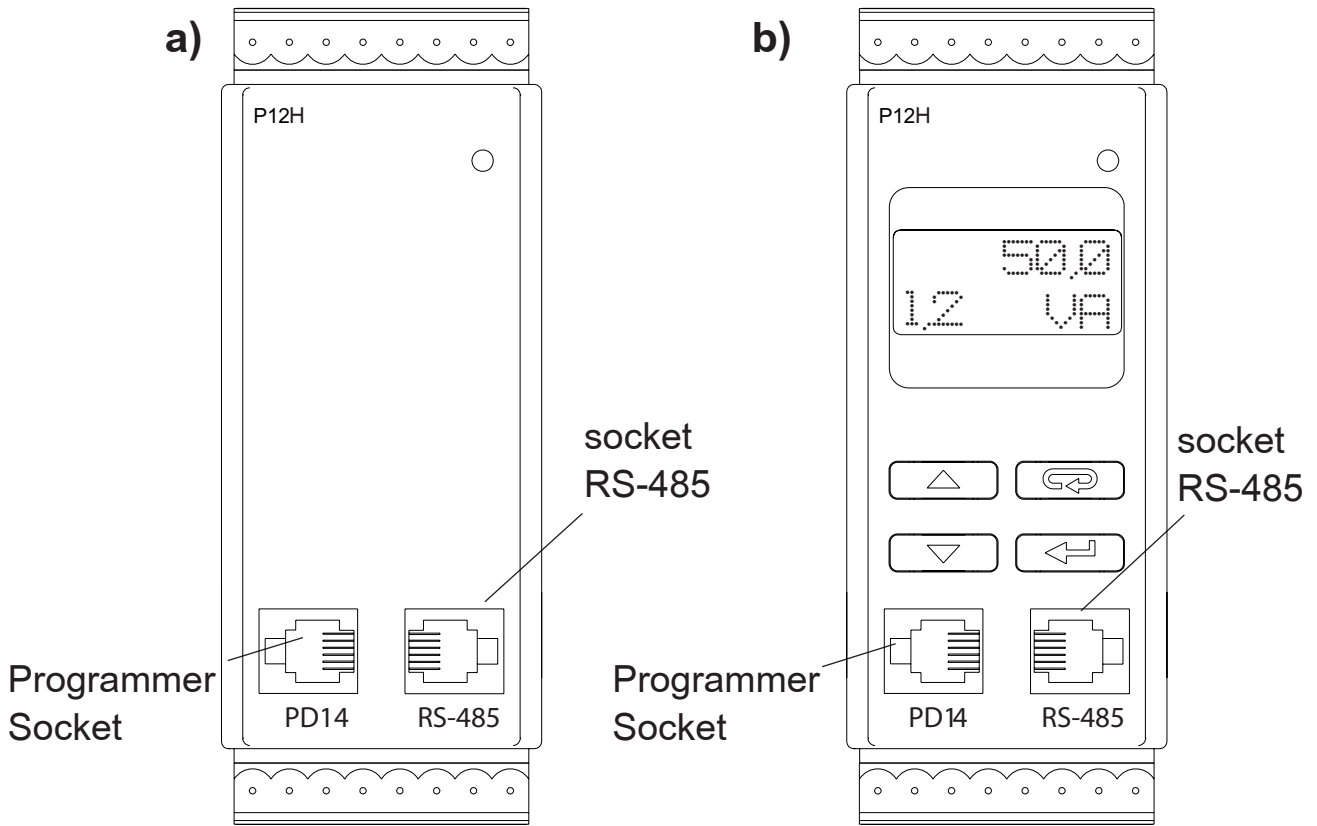

Fig.1 View of the transducer: a) P12H-1, b) P12H-2

2. SET OF THE P12H TRANSDUCER

The set is composed of:

- P12H transducer 1 pc
- service manual 1 pc
- guarantee card 1 pc
- plug with screw terminals
or self-locking terminals 4 pcs
- hole plug of the programmer socket 2 pcs

When unpacking the transducer, please check whether the type and execution code on the data plate correspond to the order code.

3. BASIC REQUIREMENTS, OPERATIONAL SAFETY

Symbols located in this service manual mean:



Especially important, one must acquaint with this before connecting the transducer. The non-observance of notices marked by these symbols can occasion the damage of the transducer.



One must pay attention when the transducer is working contrary to the expectations.

Remarks concerning the operator safety



P12H transducers are destined to be mounted on 35 mm DIN rails. In the range of operational safety they are in conformity with the EN 61010-1 standard requirements.

- The installation and transducer connection should be operated by a qualified personnel.
One must take into consideration all accessible protection requirements.
- Before switching the instrument on, one must check the correctness of the network lead connection.
- In case of the protection terminal connection with a separate lead one must remember to connect it before the connection of network leads.
- Do not connect the instrument to the network through an auto-transformer.
- Before taking the transducer housing out, one must turn the supply off.
- The removal of the transducer housing during the guarantee contract period may cause its cancellation.
- The programmer socket serves exclusively to connect the PD14 or PD11 programmer.
- The RS-485 socket serves exclusively to connect devices working with the MODBUS protocol.
- One must place hole plugs in not used transducer sockets (programmer and RS-485).

4. INSTALLATION

4.1 Fitting of the P12H transducer

P12H transducers are designed to be installed on a 35 mm DIN rail acc. EN 60715 (DIN EN 50 022-35). The housing is made of a self-extinguishing thermoplastics. The housing dimensions are: 45 x 120 x 100 mm. On the external side of the transducer, there are screw or terminal strips or self-locking strips on order enabling the connection of 2.5 mm² cross-section conductors.

Overall dimensions and the fixing way are shown on the fig.2.

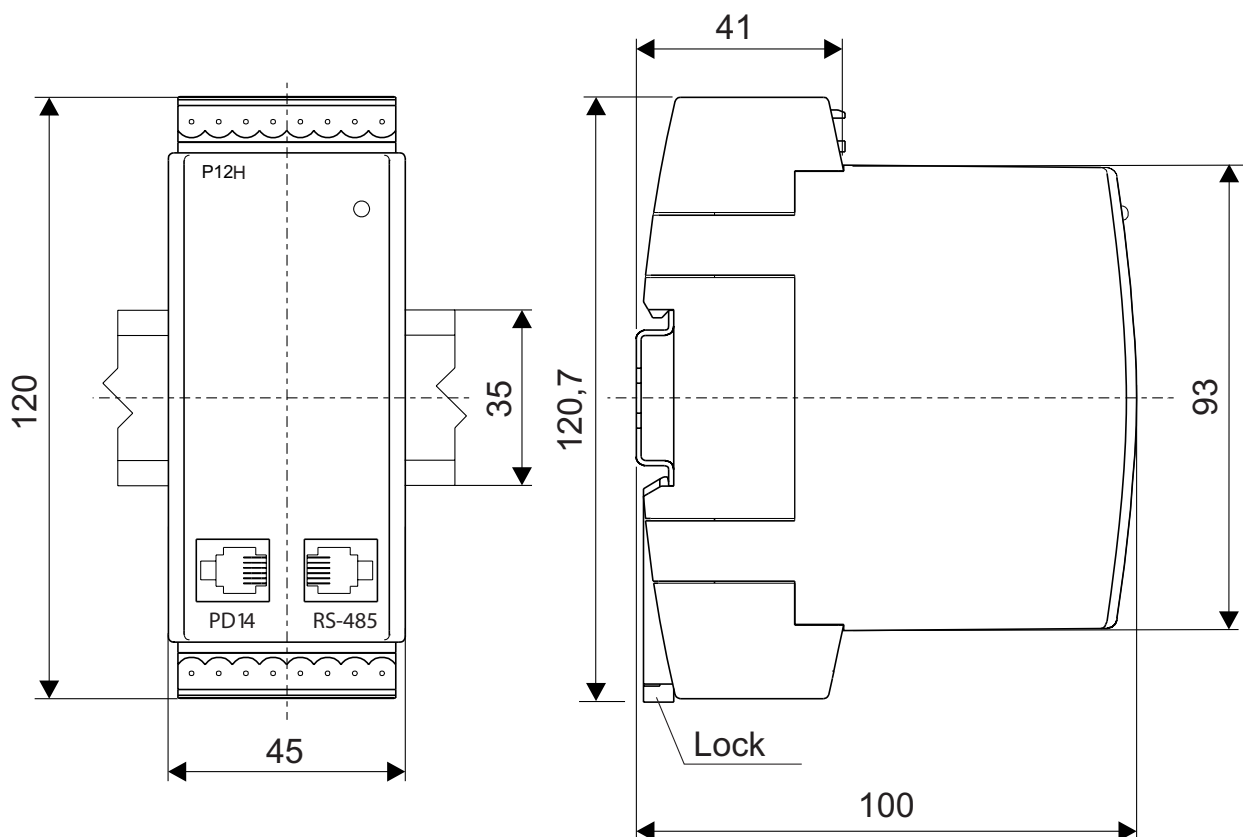

Fig.2. Overall dimensions and fixing way of P12H transducers

4.2 External connection diagrams

Electrical connections must be carried out in compliance with the Fig. 3.



a) Connection way of input signals

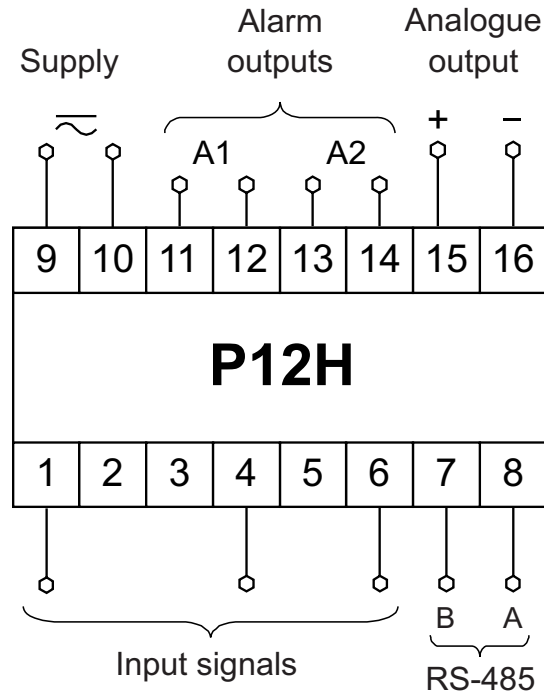

Voltage input: 100 V or 600 V

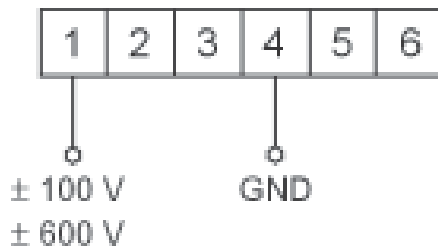

Current input: 1 A or 5 A

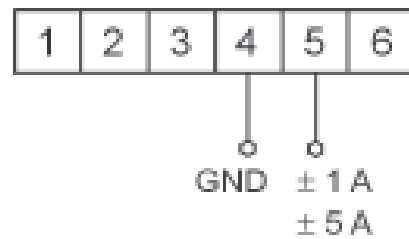

b) Connection way of the RS-485 interface

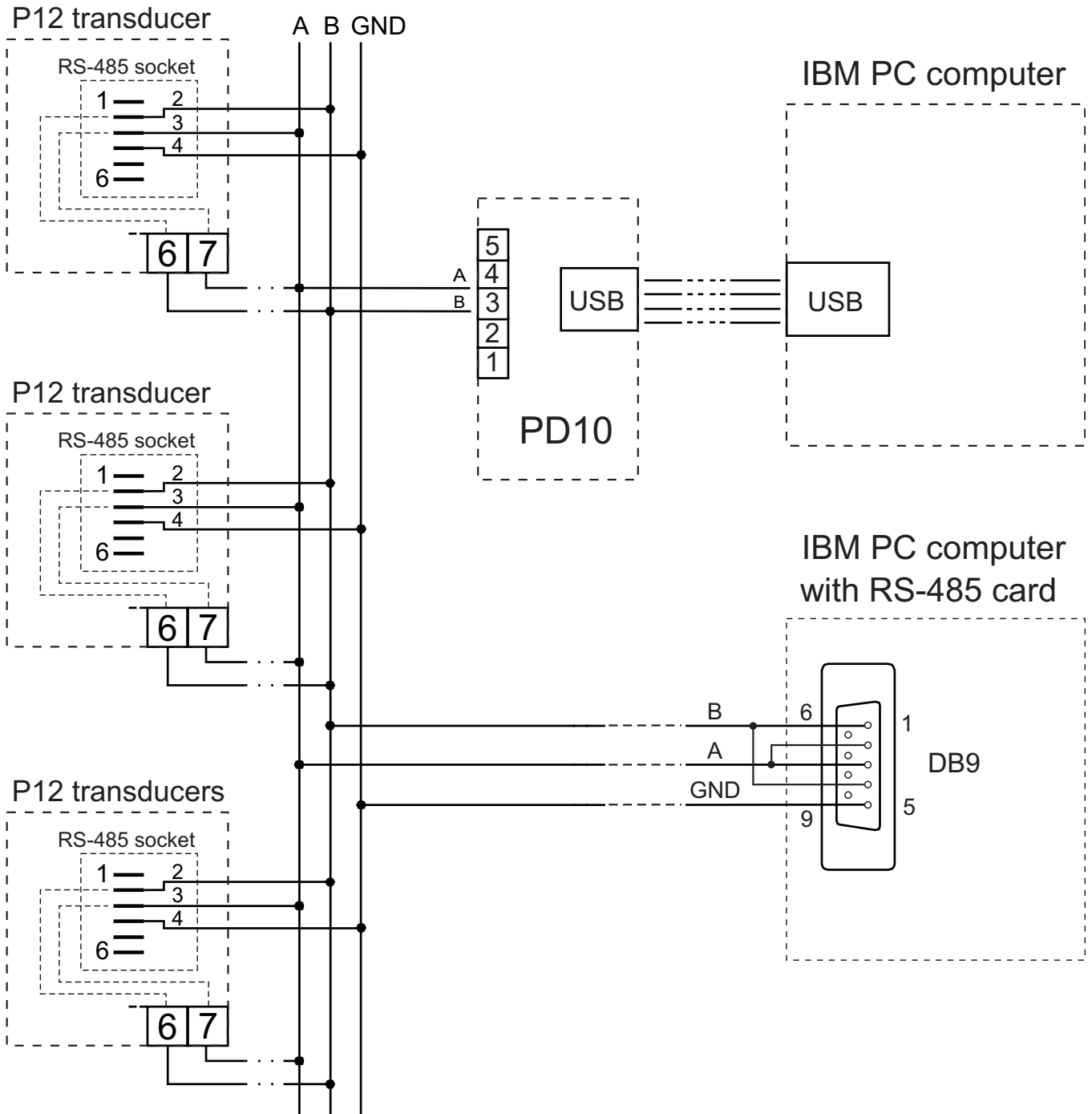
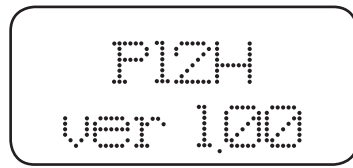

Fig. 3. External connections of the P12H transducer

Taking into consideration electromagnetic interference it is recommended to use screened wires for the connection of input and output signals. The supply must be connected by a two-wire conductor, with an appropriate diameter of wires ensuring its protection by means of an installation fuse.

5. SERVICING

After connecting external signals and turning the supply on, what is signaled by a lighted diode, the transducer displays the type and the current version of the program.



After ca 3s, the transducer automatically transits into the working mode, in which it executes the measurement and conversion into an analogue output signal. It displays the measured value, the unit of the measured or set value by the user, and marks of connected alarms.



The transducer automatically blanks void zeros. The switching of the recording on is signaled on the display (the mark „M.” means the recording switching on, the mark „E” means an empty memory, whereas the mark „F” means a filled up memory).

After filling the memory up, the transducer automatically switches the recording off.

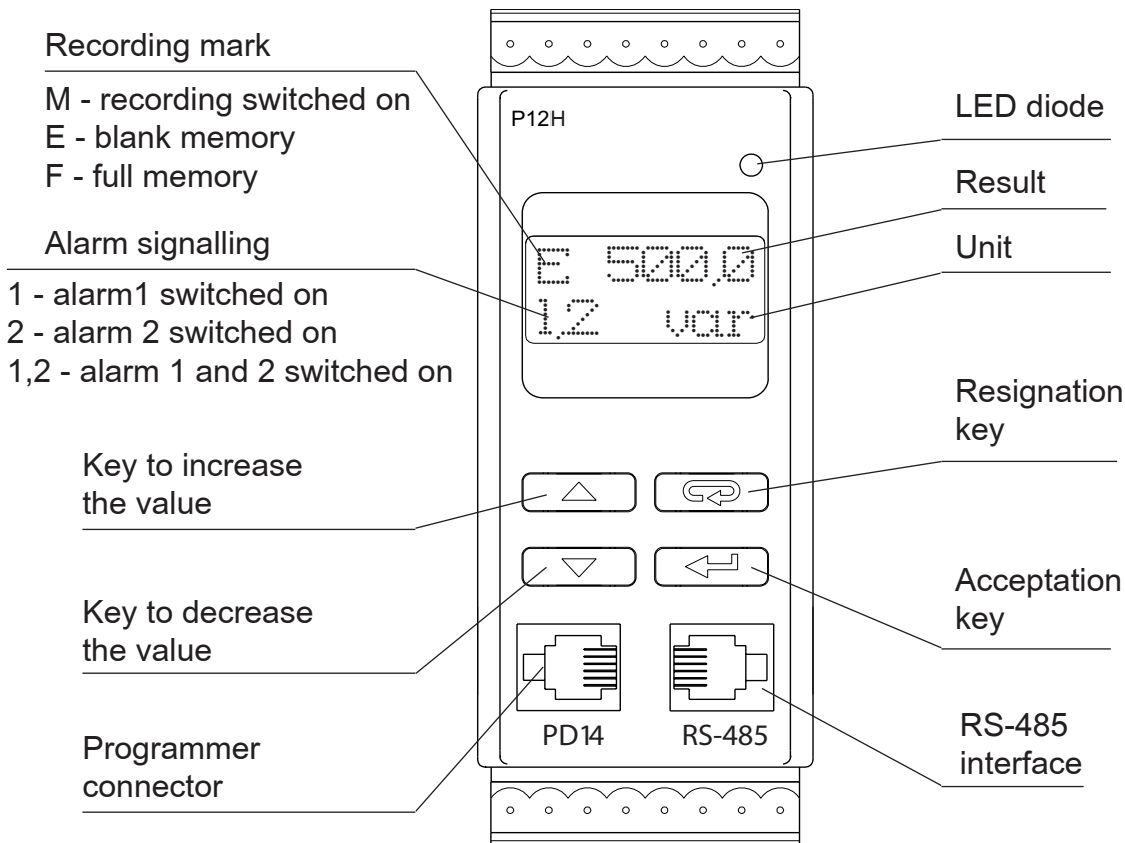

Fig. 4. Description of the P12H transducer frontal plate.

Key functions:

 - acceptance key

- entry into the programming mode (hold down ca 3 s),
- entry into the change of the parameter value mode,
- acceptance of the modified parameter value.

 - value increase key



- display of the maximal value,
- moving along the preview menu or on the programming matrix,
- modification of the chosen parameter value - value increasing.

 - value decrease key

- display of the minimal value,
- moving along the preview menu or on the programming matrix,
- modification of the chosen parameter value - value decreasing.

 - cancellation key

- entry into the menu of parameter preview (hold down ca 3 s),
- exit from the preview menu or programming matrix.
- cancellation of the parameter change.



Pressing the keys   and holding down within ca 3 s causes the erasing of the alarm indication and/or alarm outputs. This operation works exclusively when the support function is switched on.

Pressing the keys   causes the erasing of the minimal value.

Pressing the keys   causes the erasing of the maximal value.

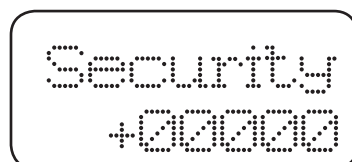
Pressing and holding the  key within ca 3 s causes the entry into the programming mode. The programming mode is secured by a security code.



Pressing and holding down of the  key within ca 3 s cause the entry into the preview menu. One must move on the preview menu by means of  and  keys. In this menu, all transducer programmable parameters are accessible only for readout, with the exception of servicing parameters.

The exit from the preview menu is carried out by means of the  key. It is possible to review recorded values in the preview menu.

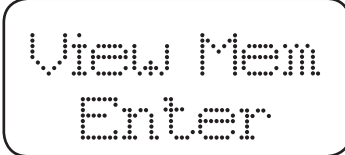

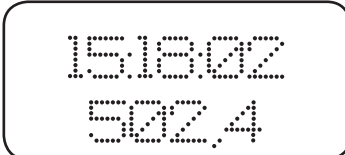

View Mem
Enter

Pressing the  key causes the entry into the review menu of recorded value



151802
502,4

The upper line informs about the sample recording time, whereas the value of the recorded sample is shown on the lower line. Stepping between recorded values happens by  and  keys.

Holding down one of these keys for more than 2 s will speed the reviewing. Pressing  key causes displaying **Pos/Size** inscription, number of sample and total memory used.

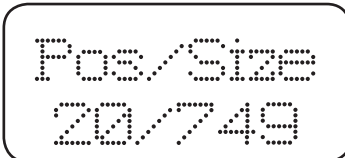

Pos/Size
20/749

The exit from the review of recorded values happens by  key.

The algorithm of the transducer servicing is shown on the Fig.5.

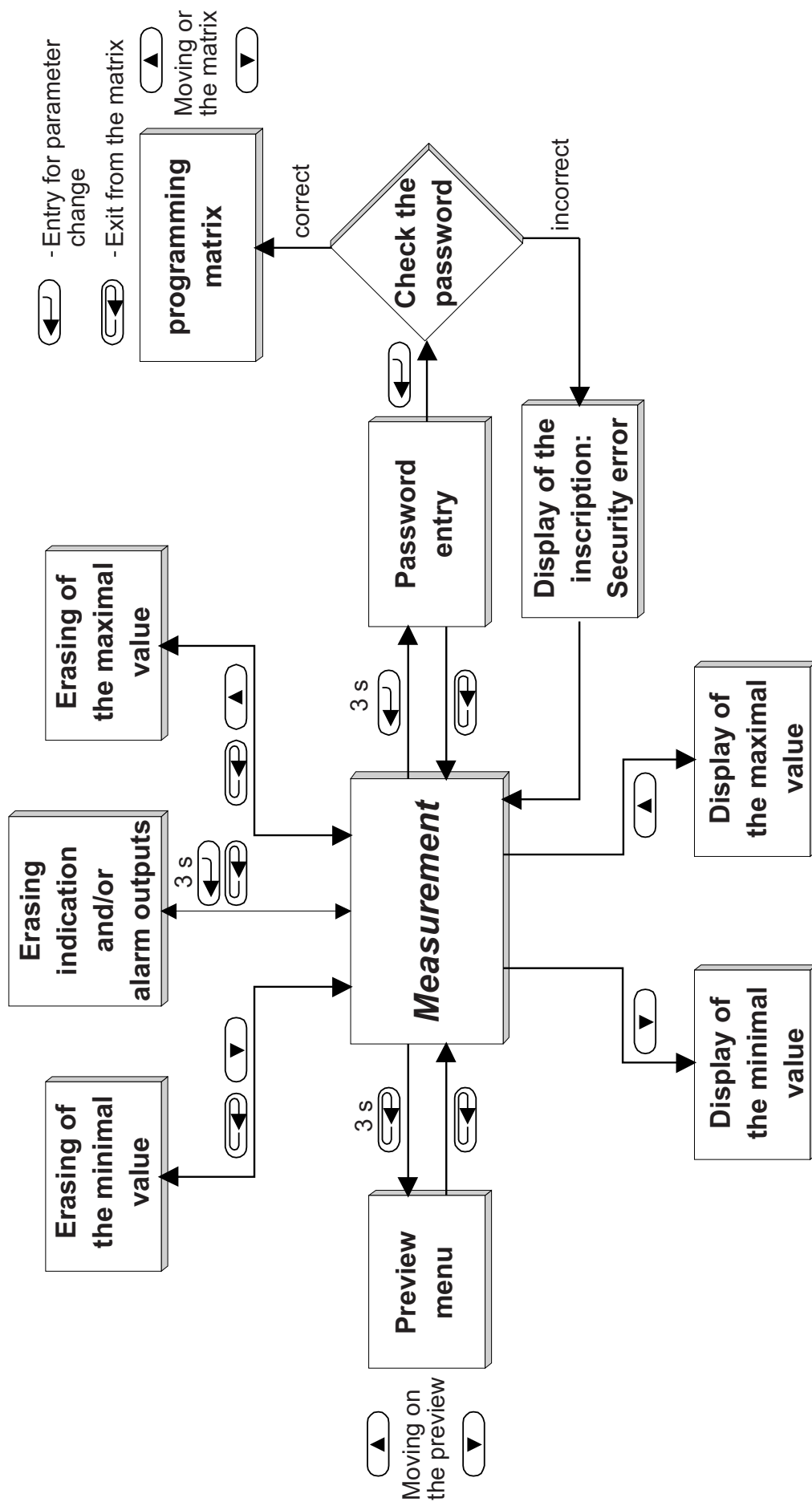
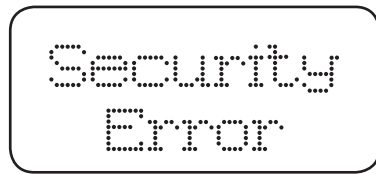
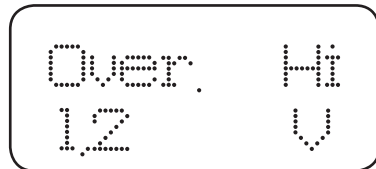

Fig. 5. Algorithm of the P12H transducer.

The appearance of mentioned below symbols and inscriptions means:



Incorrectly introduced security code.



Overrunning of the lower measuring range or lack of sensor.

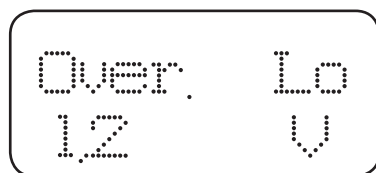

Overrunning of the lower measuring range or sensor short-circuited.

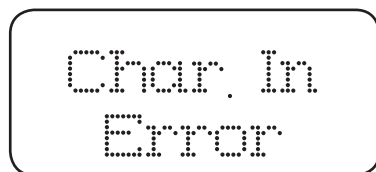

Incorrect introduction of individual characteristic parameters. In this case, the switching of the individual characteristic off follows.

One must introduce input parameters in an ascending way: $X_n I_n < X_{n+1} I_n$

The change of transducer parameters is possible:

- from the transducer keyboard (in P12H-2) - p 5.1.
- through the PD14 programmer and a PC computer - p 5.2.
- through RS-485 - p 6.5.

5.1. Change of P12H transducer parameters from the keyboard

Pressing the  key for ca 3 s causes the display of the inscription:



The introduction of the correct code causes the entry into the programming mode. The designs below present the programming way:

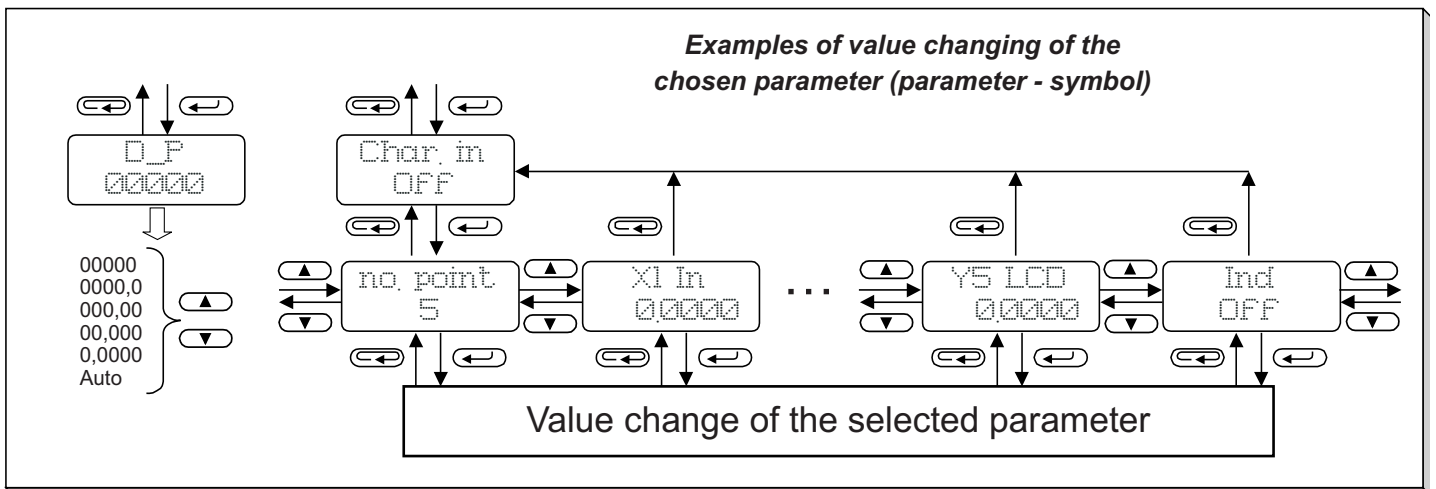
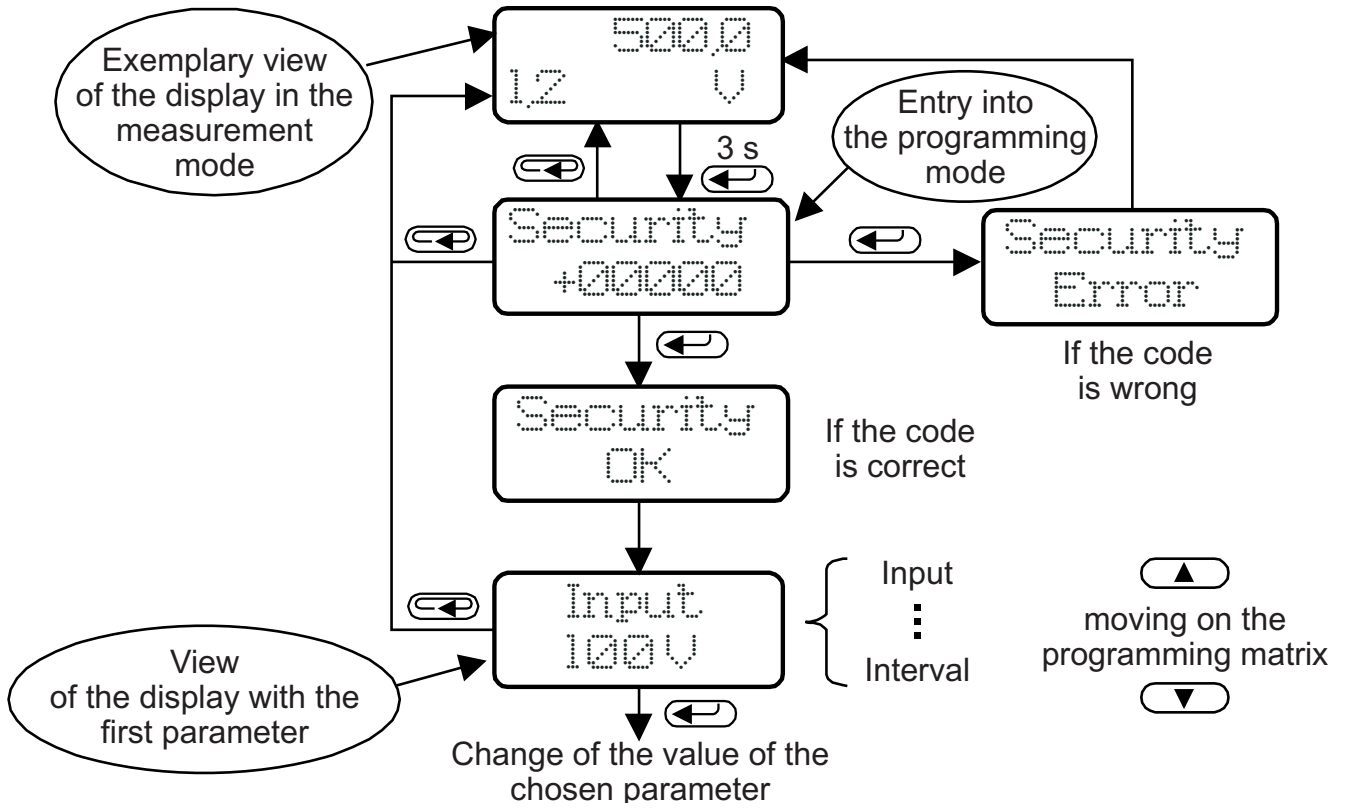

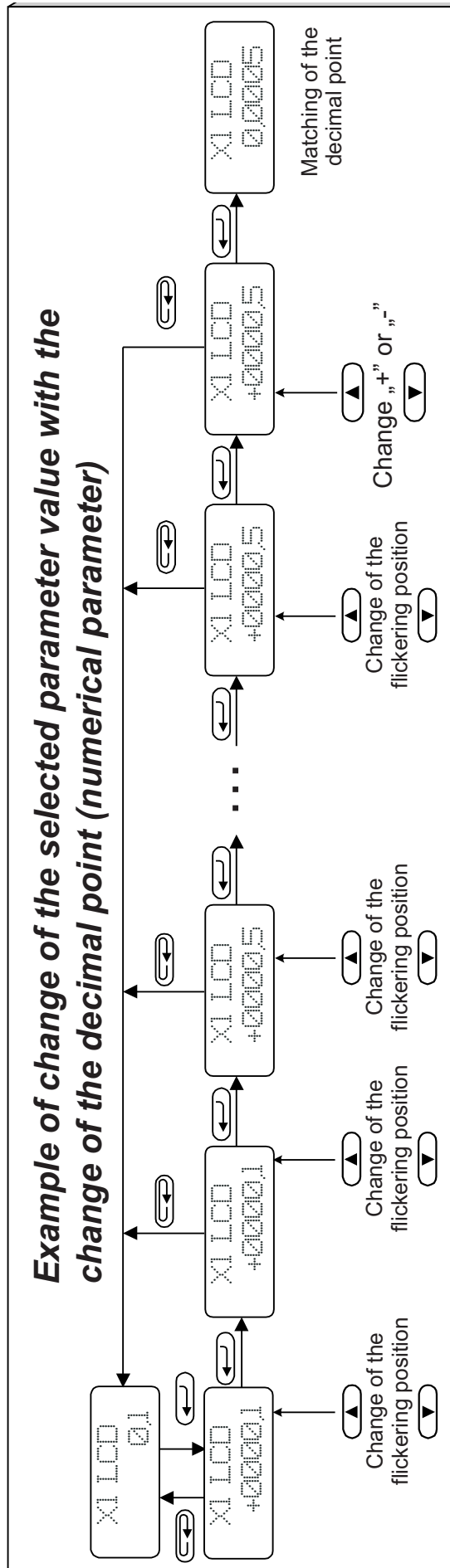
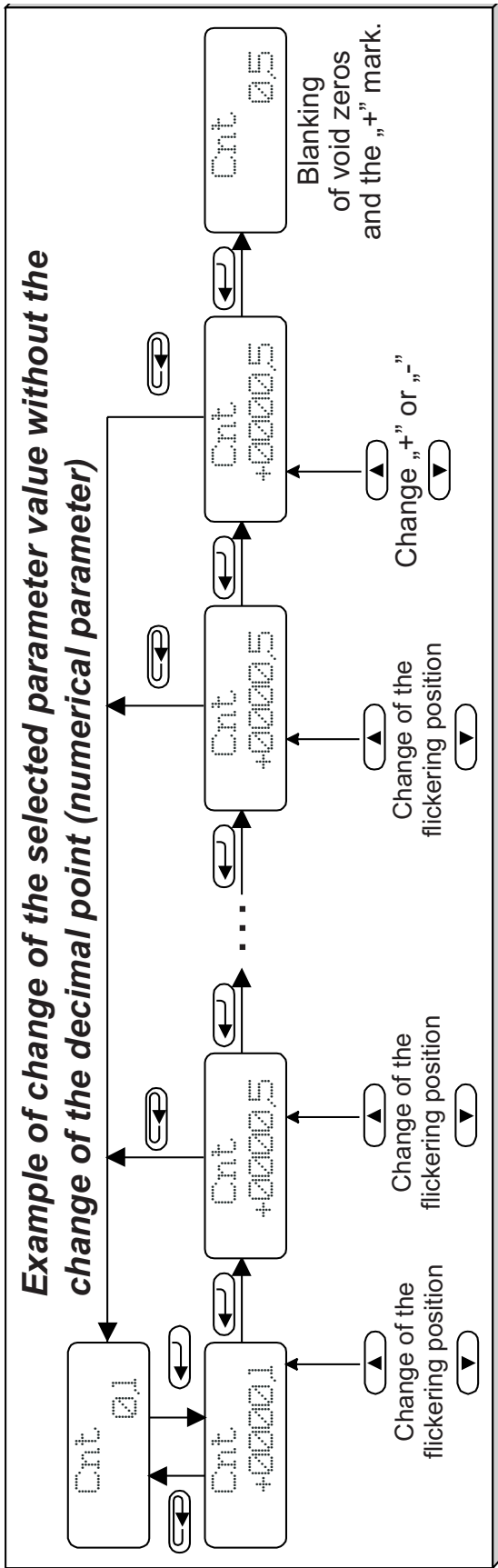

Fig. 6. Transition matrix in the programming mode

5.2. Change of P12H transducer parameters through the PD14 programmer

The way of connection of the P12H transducer through the PD14 programmer to the PC computer is shown on the Fig. 7. The programmer is connected from one side to the USB port of the PC computer, and from the other one, through a plug of RJ12 type to the P12H transducer.

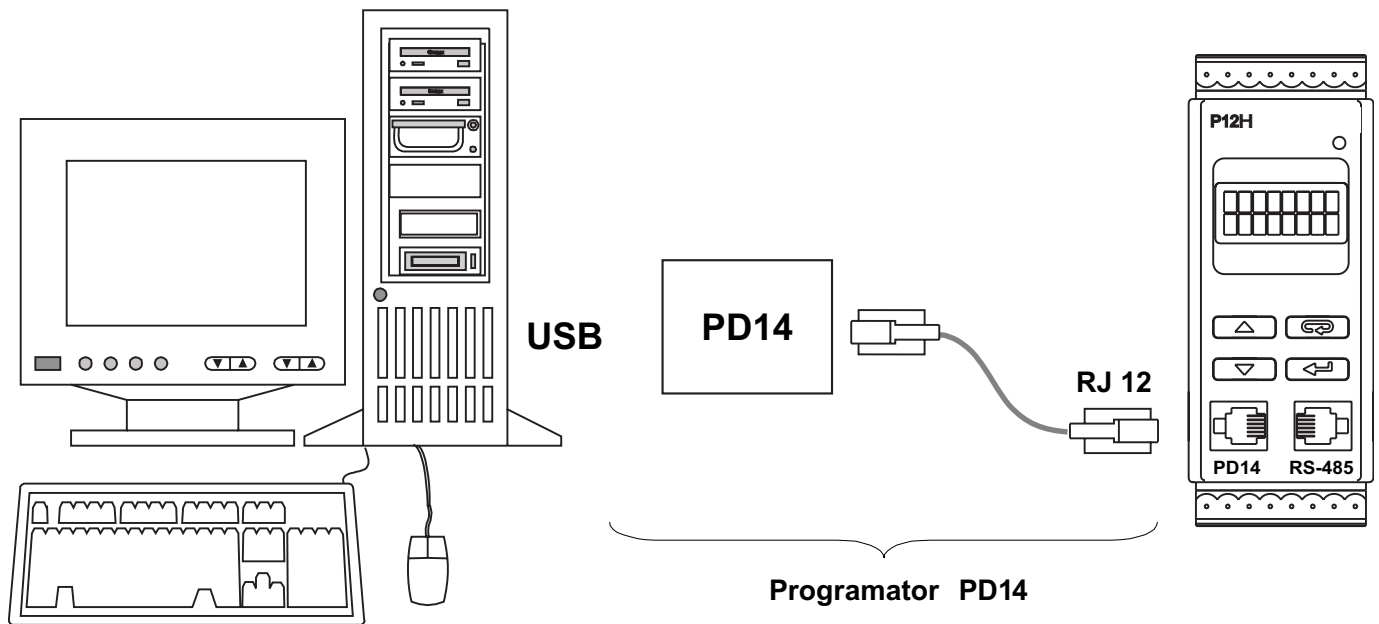

Fig. 7. Connection way of the P12H transducer through the PD14 programmer to the PC computer

Programmable transducer parameters are specified in the table 1. The programming of the parameters is possible just after the password entry.

	Symbols on the display	Description of parameters	Range of changes	
Input parameters	Input 100 V	Input type	100 V 600 V 1 A 5 A	
	Function OFF	Mathematical functions: The conversion of the result through mathematical functions follows before the individual characteristic	Off - mathematical functions switched off Sqr - raising to a power (result) ² Sqrt - extraction of roots $\sqrt{\text{result}}$ Exp - result inverse $\frac{1}{\sqrt{\text{result}}}$	
	D.P 0000.0	Setting of the decimal point. The setting operates either when the individual characteristic is switched off or on. The introduction of the decimal point which makes impossible the display of 7 characters („+ or -”, 5 characters for the result, the decimal character) on the display will cause the display of the low or upper exceeding.	Possibility of settings: 00000 0000.0 000.00 00.000 0.0000 Auto - automatic choice of the decimal point	
	Cnt 0.1	Averaging time of the measurement	0...9999.9 s	The input of the 0 causes the measurement switching off and the stoppage of the transducer work. The current time is displayed on the display.
	Unit V	Selection of the unit	Possibility of settings: V, A, μV, mV, kV, MV, μA, mA, kA, MA, mW, W, kW, MW, var, kvar, Mvar, VA, kVA, MVA, °C, °F, K, Hz, kHz, MHz, mAh, Ah, kAh, Wh, kWh, MWh, m/s, μm, mm, cm, m, km, m ² , m ³ , m ² /s, m ² /min, m ² /h, m ³ /s, m ³ /min, m ³ /h, l, l/s, l/min, l/h, l/m ² , l/m ³ , kg/s, kg/min, kg/h, ms, s, h, mN, N, kN, Pa, hPa, kPa, MPa, mmHg, bar, rad, mΩ, Ω, kΩ, MΩ, GΩ, %, °, turns rps, rpm, rev/h, m/h, km/h.	

Table 1 (continuation)

	Symbol on the display	Description of parameters	Range of changes
Alarm 1 and alarm 2 parameters (continuation)		 <p>Number of points of the individual characteristic</p>	Possible settings: 2... 21
		<div style="display: flex; flex-direction: column; align-items: center;"> <div data-bbox="453 472 660 589"></div> <div data-bbox="453 607 660 723"></div> <div data-bbox="453 741 660 857"></div> <div data-bbox="453 875 660 992"></div> <div data-bbox="453 1010 660 1126"></div> <div data-bbox="453 1144 660 1261"></div> </div> <p>Parameters of input individual characteristic. On the base of given co-ordinates of points by the user, the transducer assigns (from the system of equations) coefficients a and b of the individual characteristic</p> $\begin{cases} Y_n LCD = a \cdot X_n In + b \\ Y_{n+1} LCD = a \cdot X_{n+2} In + b \end{cases}$ <p>where: <i>X_n In</i> - measured value <i>Y_n LCD</i> - expected value on the display.</p> <p>The Fig. 9 shows the operation way of the individual characteristic.</p>	<p>Possible settings: - 99999... 99999</p> <p>One must write in the input parameters in an ascending way (<i>X_n In</i> < <i>X_{n+1} In</i>)</p> <p>The correct writing of individual characteristic parameters causes the display of the inscription:</p> <div data-bbox="1177 943 1390 1037" style="border: 1px solid black; border-radius: 10px; padding: 5px; text-align: center; width: fit-content; margin: 0 auto;">  </div> <p>However, the incorrect writing of individual characteristic parameters causes the display of the inscription:</p> <div data-bbox="1193 1267 1406 1361" style="border: 1px solid black; border-radius: 10px; padding: 5px; text-align: center; width: fit-content; margin: 0 auto;">  </div> <p>and the switching of the individual characteristic off.</p>
			<p>Switching off or on of the linear individual characteristic of the user - („individual characteristic of the input”). Fig. 9a.</p>

Table 1 (continuation)

Alarm 1 and alarm 2 parameters	<div style="border: 1px solid black; border-radius: 10px; padding: 5px; display: inline-block;"> Low AI1 0,0 </div>	Lower alarm threshold	-99999...99999
	<div style="border: 1px solid black; border-radius: 10px; padding: 5px; display: inline-block;"> Low AI2 200,0 </div>		
	<div style="border: 1px solid black; border-radius: 10px; padding: 5px; display: inline-block;"> High AI1 20,0 </div>	Upper alarm threshold	-99999...99999
	<div style="border: 1px solid black; border-radius: 10px; padding: 5px; display: inline-block;"> High AI2 300,0 </div>		
	<div style="border: 1px solid black; border-radius: 10px; padding: 5px; display: inline-block;"> Type AI1 Normal </div>	Alarm type Fig.8. presents types of alarms.	Normal - normal, On - switched on, Off - switched off. Hand on - switched on manually; up to the time of changing the alarm type remains switched on for good. Hand off - Switched off manually; up to the time of changing the alarm type remains switched off for good.
	<div style="border: 1px solid black; border-radius: 10px; padding: 5px; display: inline-block;"> Type AI2 On </div>		
<div style="border: 1px solid black; border-radius: 10px; padding: 5px; display: inline-block;"> Delay AI1 0,0 </div>	Delay of alarm operation The parameter is defined in seconds, ie one must give after how many seconds from its occurrence, the alarm operation will follow. The alarm operation occurs after the measurement averaging. The alarm switching-off follows without delay.	0.0...9999.9 The introduction of 0.0 causes the operation at the moment of the alarm occurrence.	
<div style="border: 1px solid black; border-radius: 10px; padding: 5px; display: inline-block;"> Delay AI2 5,0 </div>			

Table 1 (continuation)



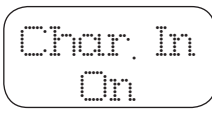
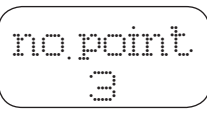
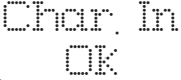
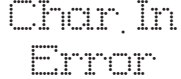
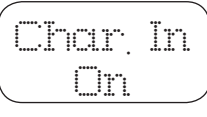



	Symbols on the display	Description of parameters	Range of changes
Alarm 1 and alarm 2 parameters (continuation)	<div style="border: 1px solid black; border-radius: 10px; padding: 5px; text-align: center; margin-bottom: 10px;"> Hold Al1 OFF </div> <div style="border: 1px solid black; border-radius: 10px; padding: 5px; text-align: center;"> Hold Al2 Relay </div>	<p>The maintenance of the alarm indication.</p> <p>In the situation when the maintenance function is switched on after the withdrawal of the alarm, state on the display and/or the contact state does not change. It signals the alarm state till the moment of its termination by means of the key  and  during ca 3 s.</p>	<p>Off - Maintenance switched off,</p> <p>LCD - Maintenance of the alarm signalling on the display,</p> <p>Relay - maintenance of the alarm relay,</p> <p>LCD+Rel - maintenance of the alarm indication on the display and the alarm relay.</p>
	Output parameters	<div style="border: 1px solid black; border-radius: 10px; padding: 5px; text-align: center;"> Char Out OFF </div>	<p>Switching on or off of the individual linear user's characteristic - („ the individual characteristic of the analogue output”). Fig. 9b.</p>
<div style="border: 1px solid black; border-radius: 10px; padding: 5px; text-align: center; margin-bottom: 5px;"> X1 LCD 0,0 </div> <div style="border: 1px solid black; border-radius: 10px; padding: 5px; text-align: center; margin-bottom: 5px;"> Y1 Out. 0,0 </div> <div style="border: 1px solid black; border-radius: 10px; padding: 5px; text-align: center; margin-bottom: 5px;"> X2 LCD 0,0 </div> <div style="border: 1px solid black; border-radius: 10px; padding: 5px; text-align: center;"> Y2 Out. 0,0 </div>		<p>Parameters of the individual characteristic of the analogue output.</p> <p>Based on user defined coordinates of two points, the transducer determines (from the system of equations) coefficients a and b of the individual characteristic.</p> $\begin{cases} Y1 Out = a \cdot X1 LCD + b \\ Y2 Out = a \cdot X2 LCD + b \end{cases}$ <p>Where: X1 LCD and X2 LCD - displayed value, Y1 Out and Y2 Out - expected value on the analogue output. Fig. 9. presents the graphical illustration explaining the idea of the individual characteristic.</p>	<p>Possibilities of settings: -99999...99999</p> <p style="text-align: center; color: gray; font-size: 1.2em; transform: rotate(-15deg); opacity: 0.5;"> Accessible when the individual characteristic is switched on </p>

Table 1 (continuation)

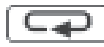
Output parameters (continuation)		Baude rate of the RS-485 interface	2400 b/s 4800 b/s 9600 b/s
		Kind of transmission through the RS-485 interface	Off - interface switched off ASCII 8N1 ASCII 7E1 ASCII 7O1 RTU 8N2 RTU 8E1 RTU 8O1 RTU 8N1
		Device address	0... 247
Servicing parameters		Factory parameters Factory parameters are presented in the table 2.	Pressing key causes the registration of factory parameters.
		Introduction of a new password	- 99999... 99999
		Display test The display test consists on a successive lighting of the first line LCD segments, and next the whole line. The same test is carried out for the second line.	Pressing key causes the test switching on. Pressing key ends the test.
		Setting of the current time. Time format: hh:mm:ss	00:00:00 ... 23:59:00

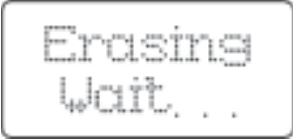
Table 1 (continuation)

	Symbols on the display	Description of parameters	Range of changes
Recording parameters		<p>Switching the recording on or off. At the moment of the recording switching on, the transducer erases the previous memorised values.</p> 	<p>On - recording switched on Off - recording switched off</p>
		<p>Time of the recording start. Time format: hh:mm:ss</p>	<p>00:00:00 ... 23:59:59</p>
		<p>Date of the recording start. Date format: dd.mm.yy This is an information parameter. It is not to define the date the recording should start from, just to inform when the recording was started.</p>	<p>00.00.00 ... 99.99.99</p>
		<p>Time interval of the recording. Define time period - how often the result should be saved.</p>	<p>00:00:00 ... 99:59:59</p>

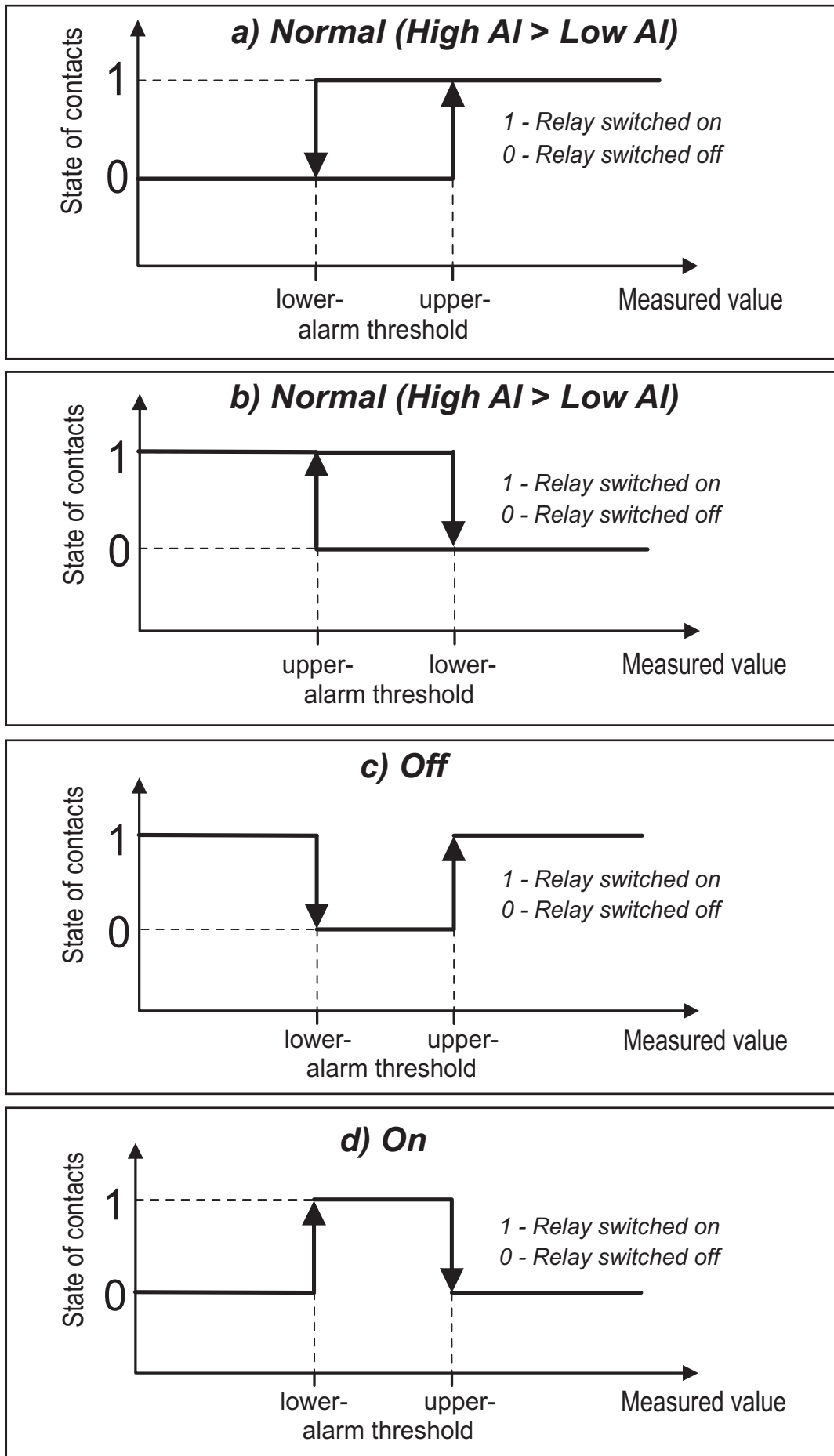
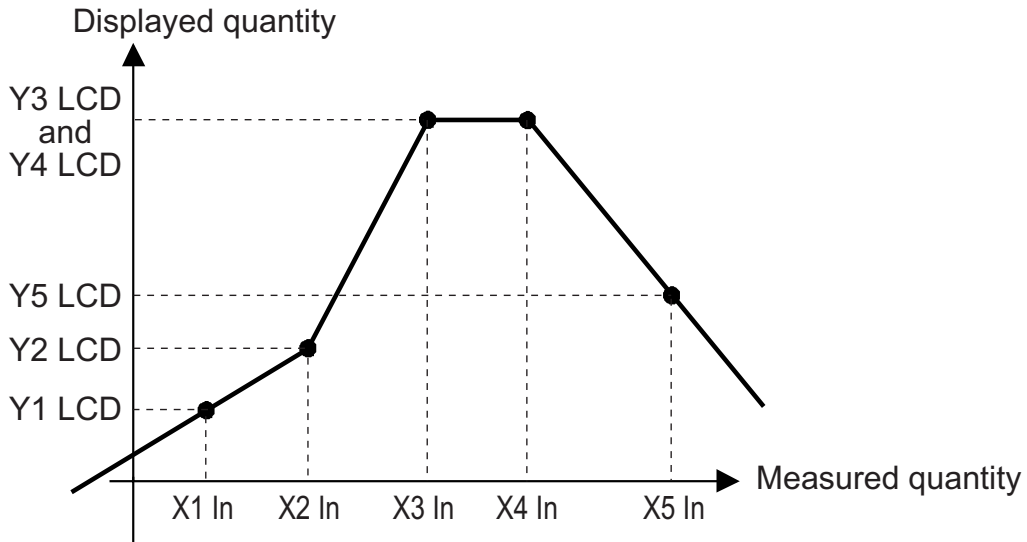

Fig. 8. Alarm types: a), b) normal c) switched off d) switched on.

a)



X1 In value on the transducer input => Y1 LCD value on the display

.

X5 In value on the transducer input => Y5 LCD value on the display
The other points of the characteristic are calculated.

b)

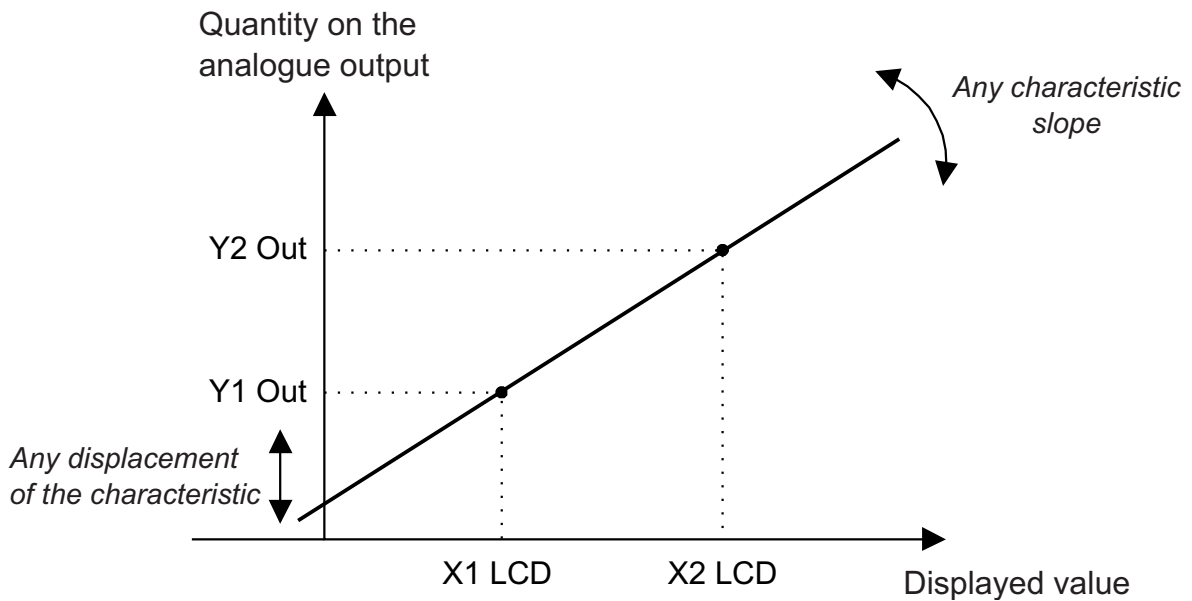

X1 LCD value on the display => Y1 Out value on analogue output

X2 LCD value on the display => Y2 Out value on analogue output

The other points of the characteristic are calculated.

**Fig .9. Individual characteristic: a) of the display,
b) of the analogue output.**

Caution! 

- In case of the display individual characteristic connection, the result on the display is linearly converted according to the introduced **X1,2 In** and **Y1,2 LCD** parameters.
- In case of the analogue output individual characteristic connection, the measurement result is linearly converted according to the introduced **X1,2 LCD** and **Y1,2 Out** parameters.
- The transducer currently the value of the presently introduced parameter. In case when the introduced value overruns the upper or lower range of changes given on the table 1, the transducer will not carry out the parameter recording.
- In case of the **Input type** change, a simultaneous change of the unit and decimal point follows, optimally for the given input.
- The recording switching off occurs in the cases: switching off the recording from the programming matrix, change of the input type, Cnt=0 setting and at the renewed connection of the transducer to the mains.

Standard parameters of the P12H transducer

Table 2

<i>Parameter description</i>	<i>Standard value</i>
Input	600 V
Function	Off
D_P	0000.0
Cnt	0.1
Unit	V
Char. In	Off
no.point	2
X1 In,Y1 LCD,X2 In,Y2 LCD	0
Low AI1, Low AI2	- 600
High AI1, High AI2	600
Type AI1, Type AI2	Off
DelayAI1, DelayAI2	0
Hold AI1, Hold AI2	Off

Standard parameters of the P12H transducer

Table 2 (continuation)

<i>Parameter description</i>	<i>Standard value</i>
Char. Out	Off
X1 LCD, Y1 Out, X2 LCD, Y2 Out	0
Baud	9600
Mode	RTU 8N2
Address	1
Security	0
Time	00:00:00
Memory	Off
StartMem	00:00:00
DateMem	70.01.01
Interval	00:15:00

n - amount of points of the individual characteristic

6. RS-485 INTERFACE

P12H programmable digital transducers have a serial link in the RS-485 standard for the communication in computer systems and with other devices fulfilling the Master function. An asynchronous character MODBUS communication protocol has been implemented on the serial link. The transmission protocol describes the manners of information change between devices through the serial link.

6.1. Manners of the serial interface connection

The RS-485 standard allows the direct connection up to 32 devices on a 1200 m long single serial link.

In order to connect a greater number of devices it is necessary to use additional intermediary-separating systems.

The leading out of the interface line is given in the transducer service manual. To obtain a correct transmission it is necessary to connect the lines **A** and **B** to their equivalents in other devices. The connection must be carried out by means of screened conductors. The screen must be connected to the protective terminal in a single point.

The **GDN** line serves to the extra protection of the interface line in case of long connections. One must connect it to the protective terminal (this is not necessary for a correct interface operation).

To obtain the connection with IBM PC class computer, a converter USB into RS-485 of PD10 type (produced by LUMEL S.A.) or an RS-485 interface card is indispensable.

The connection way of P12 transducer through a PD10 converter is presented on Fig.3.

The denotation of transmission lines for the card in the PC computer depends on the card producer.

6.2. Description of the MODBUS implementation

The implemented protocol is in compliance with the specification PI-MBUS-300 Rev G of the Modicon Company.

List of parameters of the transducer serial link in the MODBUS protocol:

- transducer address 1...247
- baud rate 2400, 4800, 9600 bit/s
- working mode ASCII, RTU
- information unit ASCII: 8N1, 7E1, 7O1,
 RTU: 8N2, 8E1, 8O1, 8N1
- maximal response time 300 ms

The parameter configuration of the serial link is described in the further part of the service manual. This configuration consists on the settlement of the baud rate (**Baud** parameter), device address (**Address** parameter), and the type of the information unit (**Mode** parameter).

Note: Each transducer connected to the communication network must:

- the unique address, different from other devices connected to the network,
- the same baud rate and type of the information unit.

6.3. Description of the MODBUS protocol functions

In the P12 transducers series the following MODBUS protocol functions are implemented:

Function description Table 3

Code	Meaning
03 (03 h)	Read-out of n-registers
06 (06 h)	Recording of a single register
16 (10 h)	Recording of n-registers
17 (11 h)	Identification of the slave device

Read-out of n-registers (code 03 h)

The function is inaccessible in the publication mode.

Example: read-out of 2 registers starting from the register which the address is 1 DBDh (7613).

Request:

Device address	Function	Register address Hi	Register address Lo	Number of registers Hi	Number of registers Lo	Control total CRC
01	03	1D	BD	00	02	52 43

Response:

Device address	Function	Number of bytes	Register value 1DBD (7613)				Register value 1DBE (7614)				Control total CRC
01	03	08	3F	80	00	00	40	00	00	00	42 8B

Recording of values into the register (code 06h)

The function is accessible in the publication mode.

Example: recording of the register which address is 1DBDh (7613)

Request:

Device address	Function	Register address Hi	Register address Lo	Register value 1DBD (7613)				Control total CRC
01	06	1D	BD	3F	80	00	00	85 AD

Response:

Device address	Function	Register address Hi	Register address Lo	Register value 1DBD (7613)				Control total CRC
01	06	1D	BD	3F	80	00	00	85 AD

Recording into n-registers (code 10h)

The function is accessible in the publication mode

Example: recording of 2 registers starting from the register which address is 1DBDh (7613).

Request:

Device address	Function	Register address		Number of registers		Number of bytes	Value for the register 1DBD (7613)				Value for the register 1DBE (7614)				Control total CRC
		Hi	Lo	Hi	Lo										
01	10	1D	BD	00	02	08	3F	80	00	00	40	00	00	00	03 09

Response:

Device address	Function	Register address Hi	Register address Lo	Number of registers Hi	Number of registers Lo	Control total (CRC)
01	10	1D	BD	00	02	D7 80

Report identifying devices (code 11h)

Request:

Device address	Function	Control total (CRC)
01	11	C0 2C

Response:

Device address	Function	Number of bytes	Device identifier	Device state	Field depending the type of device	Control total
X	11	08	X	FF	XXXXXX	

Device address	depending on the set value,
Function	Number of function 0x11,
Number of bits	0x08,
Device identifier	0x71 - P12H 0x72 - P12S 0x74 - P12U 0x73 - P12O 0x79 - P12P
Device state	0xFF
Field depend on the device type	XXXXXX
Device name	- transmitted as an ASCII character and defines the type of transducer: H - 0x48, 48 X X X X X S - 0x53, 53 X X X X X U - 0x55, 55 X X X X X O - 0x4F, 4F X X X X X P - 0x50, 50 X X X X X
Analogue output	- field depending on the type of the analogue output, - 0x00 - voltage analogue output, X 00 X X X X - 0x01 - current analogue output, X 01 X X X X
No. of the software version	- software version implemented into the transducer XX_ _ _ _ 4-byte variable of the floating type
Control total	- 2 bytes in case of work in the RTU mode - 1 byte in case of work in the ASCII mode

Example:

Work in the RTU mode, eg: **Mode = TRU 8N2** (value 0x02 in read-out/recording case through the interface)

P12H transducer

Execution with a voltage analogue output: **00**

Nr of the software version: **1.00**

Device address set on: **Address=0x01**

For such a type of transducer the frame has the following form:

Device address	Function	Number of bytes	Device identifier	Device state	Field depending of the device type	Control total (CRC)
01	11	08	71	FF	48 00 3F 80 00 00	FE 1B

6.4. P12 transducers' register map

P12 transducers' register map

Table 4

Address range	Typ of value	Description
7000-7200	Float (32 bits)	The value is placed in two successive 16-bit registers. Registers enclose the same data as 32-bit registers from the 7500 area. Registers are only for read-out.
7200-7400	Float (32 bits)	The value is placed in two successive 16-bit registers. Registers enclose the same data as 32-bit registers from the 7600 area. Registers can be read out and recorded.
7500-7600	Float (32 bits)	The value is placed in a 32-bit register. Registers are only for read-out.
7600-7700	float (32 bits)	The value is placed in a 32-bit register. Registers can be read out and recorded.

6.5. Registers for recording and read-out

P12H transducer

Table 5

The value is placed in two successive 16-bit registers enclosing the same data as 32-bit registers from the 7600 area	The value is placed in 32-bit registers	Symbol	Recording (w)/ read-out (r)	Range	Description	
7200	7600	Identifier	r	-	Device identifier	
					Value	
					0 x 71 h	Identifier
7202	7601	Input	w/r	0... 3	Kind of input	
					Value	
					0	Voltage measur. -100...100 V
					1	Volt. measur. -600...600 V
					2	Current measur. -1...1 A
					3	Current measur. -5...5 A
7204	7602			No occurs ¹⁾		
7206	7603			No occurs ¹⁾		
7208	7604			No occurs ¹⁾		
7210	7605			No occurs ¹⁾		
7212	7606			No occurs ¹⁾		
7214	7607			No occurs ¹⁾		
7216	7608			No occurs ¹⁾		
7218	7609			No occurs ¹⁾		
7220	7610			No occurs ¹⁾		
7222	7611			No occurs ¹⁾		
7224	7612			No occurs ¹⁾		
7226	7613	D_P	w/r	0... 4	Decimal point	
					Value	
					0	00000
					1	0000.0
					2	000.00
					3	00.000
					4	0.0000
					5	Automat. decimal point

Table 3 (continuation)

7228	7614	Cnt	w/r	0... 9999.9	Measurement time	
7230	7615	Function	w/r	0... 3	Arithmetical functions	
					Value	
					0	Switched off
					1	Raising to a power
					2	Extraction of roots
					3	inverse
7232	7616			No occurs ¹⁾		
7234	7617			No occurs ¹⁾		
7236	7618			No occurs ¹⁾		
7238	7619			No occurs ¹⁾		
7240	7620			No occurs ¹⁾		
7242	7621	Low AL1	w/r	- 99999... 99999	Lower threshold of alarm 1	
7244	7622	High AL1	w/r	- 99999... 99999	Upper threshold of alarm 1	
7246	7623	Type AL1	w/r	0... 4	Alarm 1 type	
					Value	
					0	Normal
					1	Switched on
					2	Switched off
					3	Manually switched on
					4	Manually switched off
7248	7624	Delay AL1	w/r	0... 9999.9	Delay of alarm 1	
7250	7625	Delay AL1	w/r	0... 3	Holding of the alarm 1 signalling	
					Value	
					0	Holding switched off
					1	Signalling on LCD
					2	Relay holding
					3	Signalling on LCD and relay holding
					To erase the alarm holding, one must switch the holding off (0 value) and then return to the previously set value.	
7252	7626			No occurs ¹⁾		
7254	7627	Low AL2	w/r	- 99999... 99999	Lower threshold of alarm 2	
7256	7628	High AL2	w/r	- 99999... 99999	Upper threshold of alarm 2	

Table 3 (continuation)

7258	7629	Type AL2	w/r	0... 4	Alarm 2 type	
					Value	
					0	Normal
					1	Switched on
					2	Switched off
					3	Manually switched on
					4	Manually switched off
7260	7630	Delay AL2	w/r	0... 9999.9	Delay of the alarm 2	
7262	7631	Hold AL2	w/r	0... 3	Holding of the alarm 2 signalling	
					Value	
					0	Holding switched off
					1	Signalling on LCD
					2	Relay holding
					3	Signalling on LCD and relay holding
					To erase the alarm holding, one must switch the holding off (0 value) and then return to the previously set value.	
7264	7632		No occurs ¹⁾			
7266	7633		No occurs ¹⁾			
7268	7634		No occurs ¹⁾			
7270	7635	Char.Out	w/r	0... 1	Characteristic of analogue output	
					Value	
					0	Characteristic switched off
					1	Characteristic switched off
7272	7636	X1 LCD	w/r	-99999... 99999	Displayed lower value	
7274	7637	Y1 Out	w/r	-99999... 99999	Lower value of the analogue output	
7276	7638	X2 LCD	w/r	-99999... 99999	Displayed upper value	
7278	7639	Y2 Out	w/r	-99999... 99999	Upper value of the analogue output	
7280	7640	Time	w/r	0... 99999	Current time	
7282	7641	Unit	w/r	0... 80 ²⁾	Choice of unit	

Table 3 (continuation)

7284	7642	Memory	w/r	0... 1	Recording of measured quantity
					Value
					0 Characteristic switched off
					1 Characteristic switched on
7286	7643	Interval	w/r	0... 99,9959	Time interval of the recording
7288	7644	year	w/r	1970... 2038	Year of the recording start
7290	7645	month	w/r	1... 12	Month of the recording start
7292	7646	day	w/r	1... 31	Day of the recording start
					Parameters: Year, Month, Day are information parameters. They do not serve to define the data from which the recording is to begin, but only to inform when the recording started.
7294	7647	Start mem.	w/r	0... 23.5959	Time of recording start
					This parameter occurs with four places after the decimal point in the format gg, mmss, where: gg - means hours, mm - means minutes, ss - means seconds. In case of a wrong time introduction, the transducer will correct it automatically.
7296	7648	Del.Min	w/r	0... 1	Erasing of the minimal value
					Value
					0 No operation
					1 Erasing of the minimal value
7298	7649	Del.Max	w/r	0... 1	Erasing of the minimal value
					Value
					0 No operation
					1 Erasing of the maximal value
7300... 7310	7655... 7655	No occurs ¹⁾			
7320	7660	Year of the stored value	w/r	1970... 2038	Year of the stored value in the memory
7322	7661	Month of the stored value	w/r	1... 12	Month of the stored value in the memory
7324	7662	Day of the stored value	w/r	1... 31	Day of the stored value in the memory

Table 3 (continuation)

7326	7663	Time of the stored value	w/r	0... 23.5959	Time of the stored value in the memory																		
					<p>This parameter occurs with four places after the decimal point in the format gg, mmss, where:</p> <p>gg - means hours, mm - means minutes, ss - means seconds.</p> <p>In case of a wrong time introduction, the transducer will correct it automatically.</p>																		
7328	7664	Index of the stored value	w/r	1... 750	Number of the stored value in the memory																		
7330	7665	Status	w/r	0... 7	Status of the operation in the buffer																		
					<table border="1"> <thead> <tr> <th>Value</th> <th></th> </tr> </thead> <tbody> <tr> <td>0</td> <td>No operation</td> </tr> <tr> <td>1</td> <td>Search acc. the date and time (registers No. 7660...7663 and 7320...7326)</td> </tr> <tr> <td>2</td> <td>Search acc. the time (registers No. 7663 and 7326)</td> </tr> <tr> <td>3</td> <td>Search acc. the index (registers No. 7664 and 7328)</td> </tr> <tr> <td>4</td> <td>Load next values into the buffer (registers No. 7662...7691 and 7344...7382)</td> </tr> <tr> <td>5</td> <td>Load previous values into the buffer (registers No. 7672...7691 and 7344...7382)</td> </tr> <tr> <td>6</td> <td>Go to the first stored value in the memory</td> </tr> <tr> <td>7</td> <td>Go to the last stored value in the memory</td> </tr> </tbody> </table>	Value		0	No operation	1	Search acc. the date and time (registers No. 7660...7663 and 7320...7326)	2	Search acc. the time (registers No. 7663 and 7326)	3	Search acc. the index (registers No. 7664 and 7328)	4	Load next values into the buffer (registers No. 7662...7691 and 7344...7382)	5	Load previous values into the buffer (registers No. 7672...7691 and 7344...7382)	6	Go to the first stored value in the memory	7	Go to the last stored value in the memory
Value																							
0	No operation																						
1	Search acc. the date and time (registers No. 7660...7663 and 7320...7326)																						
2	Search acc. the time (registers No. 7663 and 7326)																						
3	Search acc. the index (registers No. 7664 and 7328)																						
4	Load next values into the buffer (registers No. 7662...7691 and 7344...7382)																						
5	Load previous values into the buffer (registers No. 7672...7691 and 7344...7382)																						
6	Go to the first stored value in the memory																						
7	Go to the last stored value in the memory																						

Table 3 (continuation)

7332	7666	Number of the stored value	r	0... 750	Number of the stored value into the memory, placed in the first buffer register
					Value
					0
					The memory is empty
					1... 750
					No. of the stored value
7334	7667	Number of recorded register	r	0... 750	Number of recorded buffer registers
					Value
					0
					The buffer is empty
					1... 750
					Number of registers
7336	7668	Year	r	1970... 2038	Year of the value in the first register
7338	7669	Month	r	1... 12	Month of the value in the first register
7340	7670	Day	r	1... 31	Day of the value in the first register
7342	7671	Time	r	0... 23.5959	Time of the value in the first register
					This parameter occurs with four places after the decimal point in the format gg, mmss, where: gg - means hours, mm - means minutes, ss - means seconds.
7344...7382	7672... 7691	Buffer	r	–	Stored values, read-out from the memory
					20 registers, including 20 stored values

7400	7700	no.point	w/r	2... 21	Number of points of the individual characteristic
7402	7701	Char. In	w/r	0... 1	Individual characteristic
					Value
					0
					Characteristic switched off
					1
					Characteristic switched on
7404	7702	X1 In	w/r	-99999...99999	Parameters of the individual characteristic
7406	7703	Y1 LCD	w/r		
7408	7704	X2 In	w/r		
7410	7705	Y2 LCD	w/r		
7412	7706	X3 In	w/r		
7414	7707	Y3 LCD	w/r		

Table 3 (continuation)

7416	7708	X4 In	w/r	-99999...99999	Parameters of the individual characteristic
7418	7709	Y4 LCD	w/r		
7420	7710	X5In	w/r		
7422	7711	Y5 LCD	w/r		
7424	7712	X6In	w/r		
7426	7713	Y6 LCD	w/r		
7428	7714	X7 In	w/r		
7430	7715	Y7 LCD	w/r		
7432	7716	X8 In	w/r		
7434	7717	Y8 LCD	w/r		
7436	7718	X9 In	w/r		
7438	7719	Y9 LCD	w/r		
7440	7720	X10 In	w/r		
7442	7721	Y10 LCD	w/r		
7444	7722	X11 In	w/r		
7446	7723	Y11 LCD	w/r		
7448	7724	X12 In	w/r		
7450	7725	Y12 LCD	w/r		
7452	7726	X13 In	w/r		
7454	7727	Y13 LCD	w/r		
7456	7728	X14 In	w/r		
7458	7729	Y14 LCD	w/r		
7460	7730	X15In	w/r		
7462	7731	Y15 LCD	w/r		
7464	7732	X16 In	w/r		
7466	7733	Y16 LCD	w/r		
7468	7734	X17 In	w/r		
7470	7735	Y17 LCD	w/r		
7472	7736	X18In	w/r		
7474	7737	Y18 LCD	w/r		
7476	7738	X19 In	w/r		
7478	7739	Y19 LCD	w/r		
7480	7740	X20 In	w/r		
7482	7741	Y20 LCD	w/r		
7484	7742	X21 In	w/r		
7486	7743	Y21 LCD	w/r		

1) In case of registers no occurring in the given transducer series, their values is 1E+20

2) Unit values

Table 4

Code	Unit	Code	Unit	Code	Unit	Code	Unit
0	V	21	°F	42	m ² /h	63	kPa
1	A	22	K	43	m ³ /s	64	MPa
2	μV	23	Hz	44	m ³ /min	65	mmHg
3	mV	24	kHz	45	m ³ /h	66	bar
4	KV	25	MHz	46	l	67	rad
5	MV	26	mAh	47	l/s	68	mOhm
6	μA	27	Ah	48	l/min	69	Ohm
7	mA	28	kAh	49	l/h	70	kOhm
8	kA	29	Wh	50	l/m ²	71	MOhm
9	MA	30	kWh	51	l/m ³	72	GOhm
10	mW	31	MWh	52	kg/s	73	%
11	W	32	m/s	53	kg/min	74	°
12	kW	33	μm	54	kg/h	75	turns
13	MW	34	mm	55	ms	76	rps
14	var	35	cm	56	s	77	rpm
15	kvar	36	m	57	h	78	rph
16	Mvar	37	km	58	mN	79	m/h
17	VA	38	m ²	59	N	80	km/h
18	kVA	39	m ³	60	kN		
19	MVA	40	m ² /s	61	Pa		
20	°C	41	m ² /min	62	hPa		

6.6. Registers only for read-out

P12H transducer

Table 5

The value is placed in two successive 16-bit registers. Registers enclose the same data as 32-bit registers from the 7600 area	The value is placed in 32-bit registers	Name	Recording (w) /read -out (r)	Range	Description
7000	7500	Identifier	r	-	Constant identifying the device
					0x71 - P12H 0x72 - P12S 0x74 - P12U 0x75 - P12O 0x76 - P12P
7002	7501	Status	r	-	Status is the register describing the transducer current state
7004	7502	Steering out	r	%	It is the register describing the steering out of the analogue output
7006	7503	Min	r	-	Minimal value of the currently measured value
7008	7504	Max	r	-	Maximal value of the currently measured value
7010	7505	Measured value	r	-	Currently measured value
7012	7506	No occurs ¹⁾			
7014	7507	Hour	r	gg, mmss	Current time
7016	7508	No occurs ¹⁾			
7018... 7096	7509... 7548	No occurs ¹⁾			

¹⁾ In case of registers no occurring in the given transducer series, their values is 1E+20

Caution!

- while exceeding the upper or the lower parameter range, „ displayed value”, „minimum”, „maximum” are set on the 1E+20 value.

For the **Cnt=0** parameter (measurement switching off or display blanking), the „ maximum”, „minimum” or „displayed value” parameters are set on the 1E +20 value

Status register describing

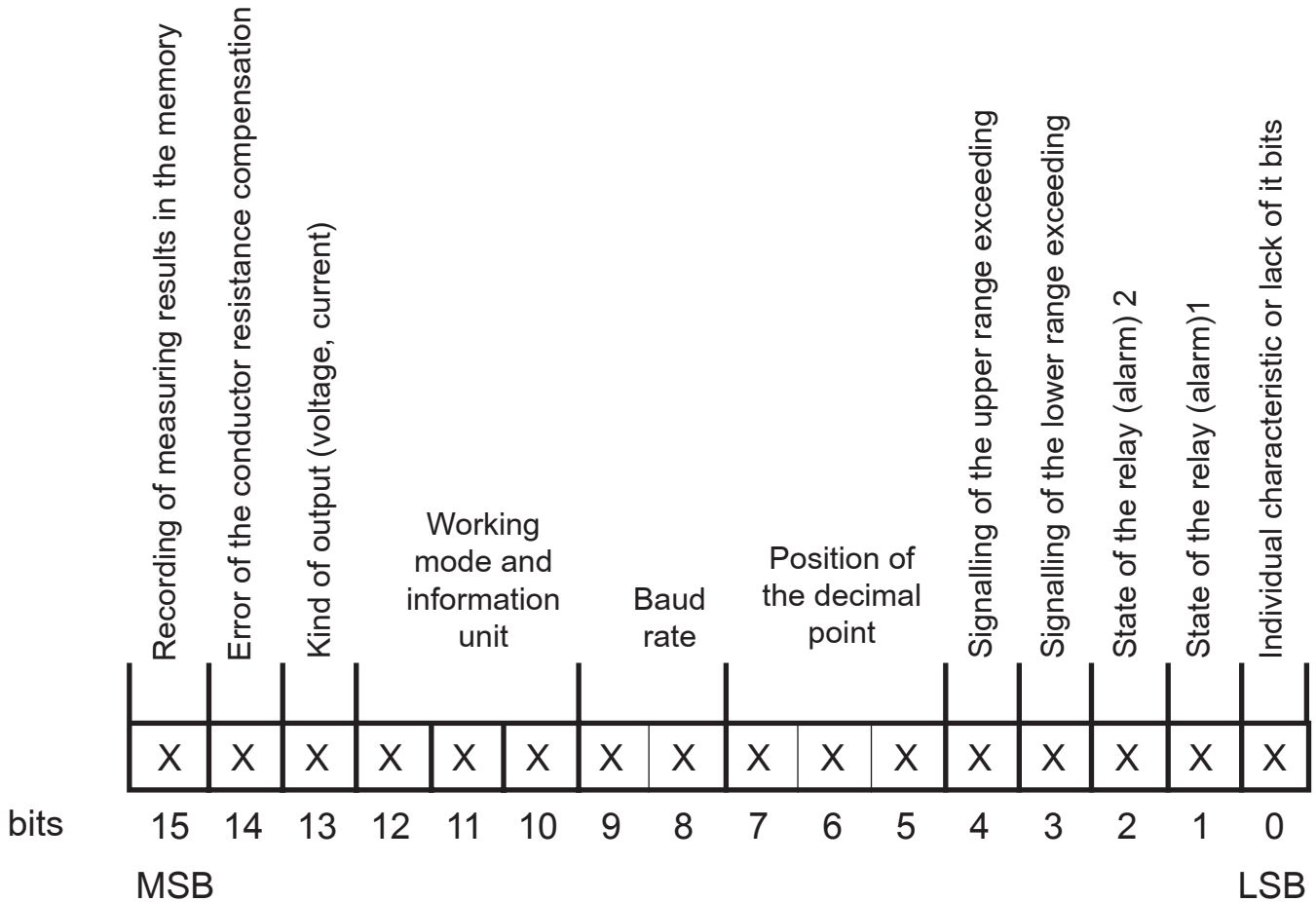

Bit-15 Recording of the measurement results in the memory

- 0 - writing switched off into the memory
- 1 - writing switched on into the memory

Bit-14 Error of the conductor resistance compensation

- 0 - lack of error
- 1 - signalling of the compensation error

Caution!

This bit is set only in P12U transducers. For other types of transducer executions, the value of this bit is free.

Bit-13 Kind of output (voltage, current)

0 - voltage

1 - current

Bit-12...10 Working mode and information unit

000 - interface switched off

001 - 8N1 - ASCII

010 - 7E1 - ASCII

011 - 7O1 - ASCII

100 - 8N2 - RTU

101 - 8E1 - RTU

110 - 8O1 - RTU

111 - 8N1 - RTU

Bit-8...9 Baud rate

00 - 2400 bit/s

01 - 4800 bit/s

10 - 9600 bit/s

Bit-5...7 Position of the decimal point

000 - lack

001 - 0.0

010 - 0.00

011 - 0.000

100 - 0.0000

101 - automatic decimal point

Bit-4 Signalling of the upper overrunning of the range

0 - normal work

1 - range overrunning

Bit-3 Signalling of the lower overrunning of the range

0 - normal work

1 - range overrunning

Bit-2 Relay (alarm) 2 state

0 - switched off

1 - switched on

Bit-1 Relay (alarm)1 state

- 0 - switched off
- 1 - switched on

Bit-0 Individual characteristic

- 0 - individual characteristic switched off
- 1 - individual characteristic switched on

7. TECHNICAL DATA

- **Inputs signal:**
 - 100... 100 V input resistance > 4.2 M Ω
 - 600... 600 V input resistance > 4.2 M Ω
 - 1... 1 A input resistance = 10 m Ω \pm 10%
 - 5... 5 A input resistance = 10 m Ω \pm 10%
- **Analog outputs** galvanically insulated with a range resolution of 0.025%:
 - current programmed 0/4... 20 mA load resistance \leq 500 Ω
 - or voltage programmed 0...10 V load resistance \geq 500 Ω
- **Relay outputs:**
 - 2 relay outputs
 - voltagless make contacts
 - maximal load capacity:
 - voltage 250 V a.c., 150 V d.c.,
 - current 5 A 30 V d.c., 250 V a.c.,
 - resistance load 1250 VA, 150 W,
 - programmable alarm thresholds,
 - three types of alarms,
 - hysteresis defined by means of the lower and upper alarm threshold,
 - signalling of alarm operation on the LCD display.
- **Digital output:**
 - interface RS-485,
 - transmission protocol MODBUS,
 - ASCII 8N1, 7E1, 7O1,
 - RTU 8N2, 8E1, 8O1, 8N1,
 - baud rate 2400, 4800, 9600 bauds,
 - max. response time to the query frame 300 ms.

■ **Communication parameters of the programmer socket:**

– interface	UART
– data bit	8
– even parity	none
– stop bit	1
– baud rate	9600 bit/s
– flow control	none

■ **Storage parameters:**

– transducer storage (recording)	750 samples
– minimal recording interval	1 s

■ **Accuracy class**

0.2
minimal sub-range: four times smaller than the full range

■ **Additional error from ambient temperature changes**



$\pm (0.1\% \text{ of the range } / 10\text{K})$

■ **Conversion time:**

– P12H-1	< 200 ms
– P12H-2	min. 200 ms (min. 100 ms averaging time of measurement + 100 ms output response time)

■ **Rated operating conditions:**

– supply voltage depending on the version code	85... <u>230</u> ...253 V a.c./d.c. 20... <u>24</u> ...50 V a.c./d.c.
– supply voltage frequency	40... <u>50/60</u> ...440 Hz
– ambient temperature	- 25... <u>23</u> ...55°C
– storage temperature	- 25...+85°C
– air relative humidity	< 95% (no condensation)
– preheating time of the transducer	10 min
– working position	any

■ Sustained overload	20%	
■ Short duration overload (3s):		
– voltage input	2 Un (< 1000 V)	
– current input	3 In	
■ Display fields	LCD 2 x 8 displays	
	indication range: - 99999... 99999	
■ Handling (in P12H-2 only)	four keys:	
		
■ Ensured protection degree through the case	IP 40	
■ Dimensions	45 x 120 x 100 mm	
■ Weight	< 300 g	
■ Fixing	on a 35 mm DIN rail	
■ Power consumption	< 4 VA	
■ Resistance against current decay	acc. EN 50082-2	
■ Electromagnetic compatibility:		
– noise immunity	acc. EN 61000-6-2	
– noise emission	acc. EN 61000-6-4	
■ Security requirements acc. IEC 61010-1:		
– installation category	III	
– pollution degree	2	
– phase-to-earth maximal working voltage	600 V d.c.	

8. BEFORE A DAMAGE WILL BE SUBMITTED



In case of incorrect symptoms please to acquaint with the below table.

SYMPTOMS	PROCEDURE
1. The transducer diode does not light. Lack of any indications.	Check the connection of the mains cable.
2. The time (eg. 12:34:43) and the „ Time ” inscriptions are alternately displayed with the „ P12H ” inscription on the display.	The number of measurements Cnt=0 has been introduced. The transducer is working in the SLEEP
3. Inscriptions Over.Hi or Over.Lo are displayed on the display.	Check the correctness of the input signal connection. See the service manual. Check also the setting of D_P and Char.In parameters.
4. A signal inconsistent with our expectations occurs on the transducer output.	One must check whether the load resistance of the analogue output is compatible with the technical data. Check whether the individual characteristic is not switched on. In case of necessity make the change of the individual characteristic parameters or introduce factory parameters: Par.fact .
5. Lack of possibility to enter into the programming mode. The inscription Security error is displayed.	The programming mode is secured by the password. In case when the user will forgot which password had been introduced, he should phone the nearest service workshop.
6. Lack of certainty if all character fields of the display are efficient.	Enter into the programming matrix and switch the display test on. The character fields are successively lighted in the first line till the lighting of the last field. Then, the whole line is lighted. This operation is repeated for the second line. If otherwise, submit the fault to the nearest service workshop.

<p>7. During the moving along the programming mode, values not conform to the range of changes given in the table 1, occur on the display.</p>	<p>Enter into the programming matrix and accept the Par. fact. parameter. The transducer will introduce parameters acc. the table 2.</p>
<p>8. A result inconsistent with our expectations appears on the display.</p>	<p>Check whether the individual characteristic is not switched on. In case of needs, enter into the programming matrix and accept the Par. fac. parameter. The transducer will introduce parameters acc. the table 2.</p>
<p>9. Symbols of X1In , X2In, Y1 LCD, and Y2 LCD parameters are not displayed in the programming mode.</p>	<p>In case of the switched individual characteristic off, the mentioned symbols are avoided.</p>
<p>10. Despite the alarm threshold overrunning, the alarm does not switch on and lack of signalling on the display.</p>	<p>Check the introduced delay into the alarm operation. If possible correct Delay AI1, Delay AI2 parameters.</p>
<p>11. Despite the relay switching off, the alarm occurrence is still signalled on the display. Despite the alarm signalling on the display is over, the relay is still switched on.</p>	<p>Check whether the support of the alarm signalling or the relay is switched on Hold AI1, Hold AI2 parameters. In case of necessity switch it off.</p>
<p>12. Lack of possibility to erase the signalling from the display or switch the relay off by means of the combination of keys when the parameter of the alarm signalling support is switched on.</p>	<p>The alarm is still operating. The erased alarm signalling from the display is immediately displayed again. The erased relay is switched on again, at once.</p>
<p>13. Despite the alarm lasts, the erased alarm signalling from the display is not displayed again or/and the relay remains switched off.</p>	<p>Check whether a delay in the relay operation was not introduced. Delay AI1, Delay AI2 parameters.</p>

<p>14. Instead of display the measuring result, the transducer displays the parameter symbol and its value.</p>	<p>The transducer works in the review mode or the programming matrix. Press the erase key.</p>
<p>15. A delay of the alarm operation was introduced, e.g. 30 s, but the alarm, after this time did not operate.</p>	<p>The persisting alarm state was shorter than the programmed one, i.e. a state of the alarm retract occurs during the alarm operation. In that case, the transducer begins to deduct the time from the beginning.</p>
<p>16. The transducer does not communicate with the computer through the RS-485 interface.</p>	<p>Check if the interface conductors were correctly connected (A, B, GND). Then, check the setting of the interface in the programming matrix (Mode, Baud, Address). These parameters must be the same as in the used software.</p>
<p>17. The transducer does not communicate with the computer through the PD14 programmer.</p>	<p>Check whether the PD14 programmer was correctly connected. Check if in the used software the proper communication port was chosen. The programmer works only with one transducer socket.</p>

9. EXAMPLES OF P12H TRANSDUCER PROGRAMMINGS

Example 1 - Programming of the individual characteristic

We want to program in order that:

- the value 10 on the display will correspond to the value 15 V,
- the value 50 on the display will correspond to the value 20 V,
- the value 200 on the display will correspond to the value 30 V,
- the value 200 on the display will correspond to the value 100 V,
- the value 170 on the display will correspond to the value 120 V,
- However the value 80 on the display will correspond to the value 100 V, (6 points of the individual characteristic), one must:
 - enter into the programming mode and choose the **D_P** parameter responsible for the decimal point.

- set the decimal point on **00000**
- choose the **Char. In** parameter and press the  key
- choose the **no.point** parameter and introduce the value 6
- choose the **X1 IN** parameter and introduce the value 15
- choose the **Y1 LCD** parameter and introduce the value 10
- choose the **X2 IN** parameter and introduce the value 20
- choose the **Y2 LCD** parameter and introduce the value 50
- choose the **X3 IN** parameter and introduce the value 30
- choose the **Y3 LCD** parameter and introduce the value 200
- choose the **X4 IN** parameter and introduce the value 100
- choose the **Y4 LCD** parameter and introduce the value 200
- choose the **X5 IN** parameter and introduce the value 120
- choose the **Y5 LCD** parameter and introduce the value 170
- choose the **X6 IN** parameter and introduce the value 200
- choose the **Y6 LCD** parameter and introduce the value 80
- choose the **Char. In** parameter and switch individual characteristic on

Example 2 - Programming of alarm with hysteresis

If we want to program the alarm1 operation such that at the value 500.0 V the alarm was switched on and switched off at the value 50.0 V and the alarm2 operation such that at the value 300.0 the alarm was switched off and switched on at the value - 400.0 V, one must:

- enter into the programming mode, choose the **Low AI1** parameter and introduce the value 500.0
- transit to the **High AI1** parameter and introduce the value 50.0
- transit to the **Type AI1** parameter and choose the function designated as **Normal**
- choose the **Low AI2** parameter and introduce the value 300.5
- transit to the **High AI2** parameter and introduce the value - 400.0
- transit to the **Type AI2** parameter and choose the **Normal** function.

Example 3 - Programming of alarm with a set up interval with delay

If we want the alarm 1 was switched on in the interval from 100 V to 300 V and operated only after 10 seconds, one must:

- enter into the programming mode and choose the **Low AI1** parameter and

introduce the value 100,

- transit into the **High AI1** parameter and introduce the value 300,
- transit into the **Type AI1** parameter and choose the function **On**,
- transit into the **Delay AI1** parameter and introduce the value 10.0,

In case of continuation of the alarm state more than 10 seconds, the transducer will switch the alarm relay on or/and signal this on the display.

Example 4 - Programming of the analogue output

If we want to program in order that the 4.00 mA value will correspond to the displayed value 10.0 V on the analogue output, however the value 20.00 mA to the value 500.0 V, one must:

- enter into the programming mode, choose the **Char. out** parameter and switch the individual characteristic **On**,
- choose the **X1 LCD** parameter and introduce the value 10.0,
- transit to the **Y1 OUT** parameter and introduce the value 4.00,
- transit to the **X2 LCD** parameter and introduce the value 500.0,
- transit to the **Y2 OUT** parameter and introduce the value 20.00.

10. EXECUTION CODES

Execution codes of the P12H transducer

Table 6.

PROGRAMMABLE TRANSDUCER P12H	X	XX	X	X	X	XX	X
Kind of transducer:							
without a display	1						
with a display	2						
Input signal*:							
voltage measurement -100... 100 V	00						
voltage measurement - 600... 600 V	01						
current measurement - 1... 1 A	02						
current measurement - 5... 5 A	03						
Output signal:							
voltage 0... 10 V	1						
current 0... 20 mA	2						
current 4... 20 mA	3						
current 0... 5 mA	4						
Supply:							
85... 253 V a.c./d.c.	1						
20... 50 V a.c./d.c.	2						
Kind of terminals:							
socked - screw plug	0						
on order***	X						
Version:							
standard	00						
custom-made**	XX						
Acceptance tests:							
without extra quality requirements	8						
with an extra quality inspection certificate	7						
other requirements acc user's agreement**	X						

* The transducer has an universal input. One must give in order the code of the input signal which will be programmed.

** After agreeing by the producer.

*** Possible version with self-locking sockets.

The transducer maintains its class to the fourfold decrease of the basic range of the input signal. In the P12H-1 transducer, besides the basic range, one must give the required sub-range in remarks. In case when the given sub-range is smaller than the basic range divided by four, one must precise the input signal on the XX order.

CODING EXAMPLES:

1. Example of a transducer with a basic range:

P12H 2 02 3 1 0 00 8 code means:

- 2** - version of a P12H transducer with a display
- 02** - input signal: - 1... 1 A, programmed by the manufacturer
- 3** - output signal: 4... 20 mA
- 1** - supply voltage: 85... 253 V a.c./d.c.
- 0** - socket - screw-plug terminals
- 00** - standard version
- 8** - without extra quality requirements.

2. Example of a transducer with a measuring sub-range:

P12H 1 03 1 1 0 00 8, range: - 2... 2 A code means:

- 1** - version of a P12H transducer without a display
- 03** - input signal: - 5... 5 A, programmed by the manufacturer to the input range - 2... 2 A
- 1** - voltage analogue output: 0... 10 V
- 1** - supply voltage: 85... 253 V a.c./d.c.
- 0** - socket - screw-plug terminals
- 00** - standard version
- 8** - without extra quality requirements.

In case of custom-made version or to obtain more detailed information, please contact our Export Department.

11. MAINTENANCE AND GUARANTEE

The P12H transducer does not require any periodical maintenance.

In case of some incorrect unit operations:

1. Within the period given in the guarantee card and from the date of purchase:

One should take the transducer down from the installation and return it to the Manufacturer's Quality Control Department.

If the unit has been used in compliance with the instructions, the manufacturer guarantees to repair it free of charges.

The disassembling of the housing can cause the cancellation of the granted guarantee.

2. After the the guarantee period:

One should return the transducer to repair in an authorized service shop.

The producer reserves the right to make changes in design and specifications of any products as engineering advances or necessity requires.

P12H-09A



Lubuskie Zakłady Aparatów Elektrycznych - LUMEL S.A.
ul. Sulechowska 1, 65-022 Zielona Góra, Poland

Tel.: (48-68) 32 95 100 (exchange)

Fax: (48-68) 32 95 101

www.lumel.com.pl

e-mail: lumel@lumel.com.pl

Export Department:

Tel.: (48-68) 329 53 02 or 53 04

Fax: (48-68) 325 40 91

e-mail: export@lumel.com.pl