

# TRANSDUCER OF NETWORK PARAMETERS P43 TYPE



**USER'S MANUAL**





# Contents

---

<b>1. Application</b> .....	<b>5</b>
<b>2. Transducer Set</b> .....	<b>6</b>
<b>3. Basic Requirements and Operational Safety</b> .....	<b>6</b>
<b>4. Installation</b> .....	<b>7</b>
<b>5. Service</b> .....	<b>12</b>
<b>6. Archive - Power Profile</b> .....	<b>30</b>
<b>7. Error Codes</b> .....	<b>30</b>
<b>8. Serial Interfaces</b> .....	<b>31</b>
<b>9. Examples of P43 Transducer Programming</b> .....	<b>40</b>
<b>10. Technical Data</b> .....	<b>43</b>
<b>11. Execution Codes</b> .....	<b>46</b>
<b>12. Maintenance and Guarantee</b> .....	<b>47</b>



# 1. APPLICATION

---

The P43 transducer is a programmable digital instrument destined for the measurement and parameter conversion of 3 or 4-wire three-phase power networks, in balanced and unbalanced systems.

It ensures the measurement and conversion of measured values into standard analog current signals. Two relay outputs signal the overflow of selected quantities, and the pulse output can be used for the consumption monitoring of the 3-phase active energy.

Quantities measured and calculated by the transducer:

- phase voltages .....  $U_1, U_2, U_3$
- phase-to-phase voltages .....  $U_{12}, U_{23}, U_{31}$
- 3-phase mean voltage .....  $U$
- phase-to-phase mean voltage .....  $UPP$
- three-phase mean current .....  $I$
- phase currents .....  $I_1, I_2, I_3$
- phase active powers .....  $P_1, P_2, P_3$
- phase reactive powers .....  $Q_1, Q_2, Q_3$
- phase apparent powers .....  $S_1, S_2, S_3$
- phase active power factors .....  $Pf_1, Pf_2, Pf_3$
- reactive/active ratio of power factors .....  $tg\varphi_1, tg\varphi_2, tg\varphi_3$
- three-phase mean power factors .....  $Pf, tg\varphi$
- three-phase active, reactive and apparent powers ...  $P, Q, S$
- active mean power (e.g. 15 min.) .....  $P_{av}$
- three-phase active and reactive energy .....  $E_{pt}, E_{qt}$ ,
- frequency .....  $f$

The transducer possesses an archive, in which 1000 last mean power values suitably synchronized with the clock (15, 30 or 60 minutes) are stored.

Maximal and minimal values are measured for all quantities. Additionally, there is the possibility to accommodate the transducer to external measuring transducers. The transducer has a detection and signaling of incorrect phase sequence. The actualization time of all accessible

quantities does not exceed 1 second. All quantities and configuration parameters are accessible through the RS-485 interface and the USB interface.

Transducer output signals are galvanically isolated from the input signal and the supply. Outside the transducer, there are socket-plug

## 2. TRANSDUCER SET

---

The set of the P43 transducer is composed of:

- |                  |      |
|------------------|------|
| - P43 transducer | 1 pc |
| - user's manual  | 1 pc |
| - guarantee card | 1 pc |
| - CD disc        | 1 pc |

**When unpacking the transducer, please check whether the type and execution code on the data plate correspond to the order.**

## 3. BASIC REQUIREMENTS AND OPERATIONAL SAFETY

---

In the safety service scope, the transducer meets to requirements of the EN 61010-1 standard.



### **Observations Concerning the Operational Safety:**

- All operations concerning transport, installation, and commissioning as well as maintenance, must be carried out by qualified, skilled personnel, and national regulations for the prevention of accidents must be observed.
- Before switching the transducer on, one must check the correctness of connections to the network.
- Before removing the transducer housing, one must switch the supply off and disconnect measuring circuits.

- The removal of the transducer housing during the guarantee contract period may cause its cancellation.
- The P43 transducer is destined to be installed and used in industrial electromagnetic environment conditions.
- One must remember that in the building installation, a switch or a circuit-breaker should be installed. This switch should be located near the device, easy accessible by the operator, and suitably marked.

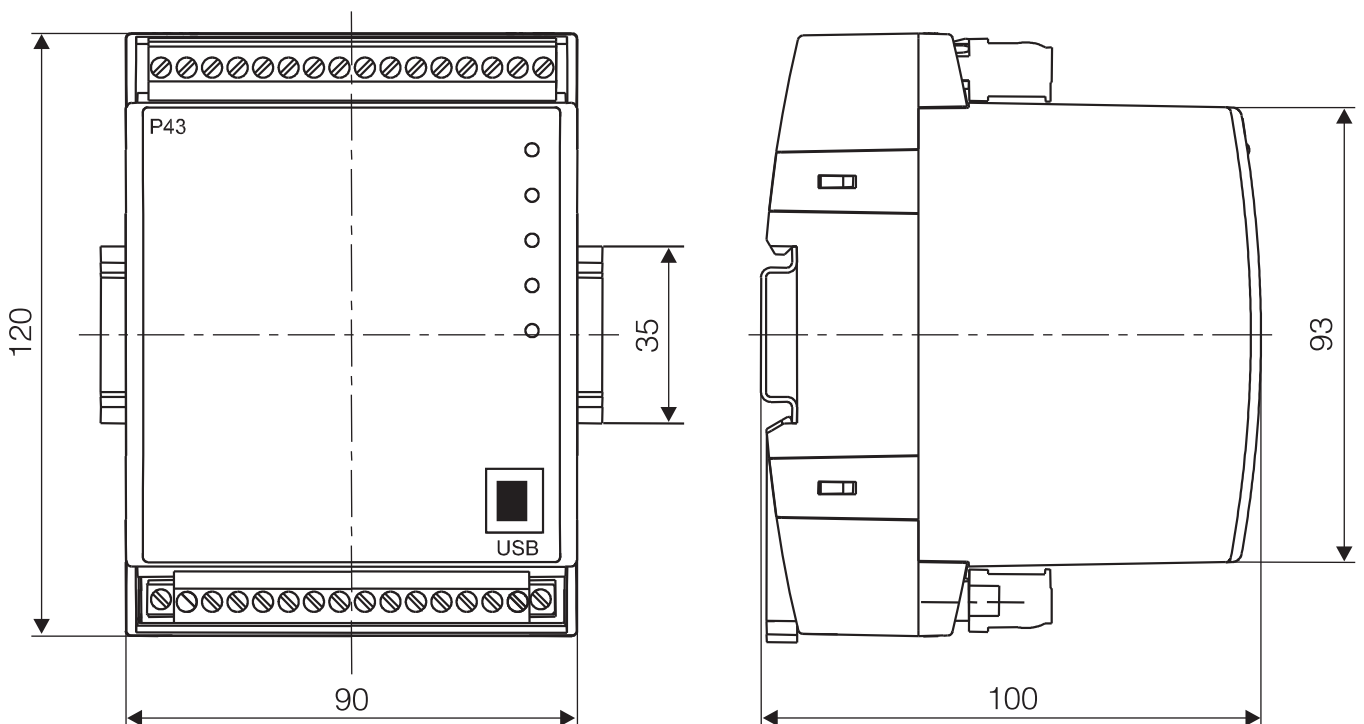
## 4. INSTALLATION

---

### 4.1. Fitting

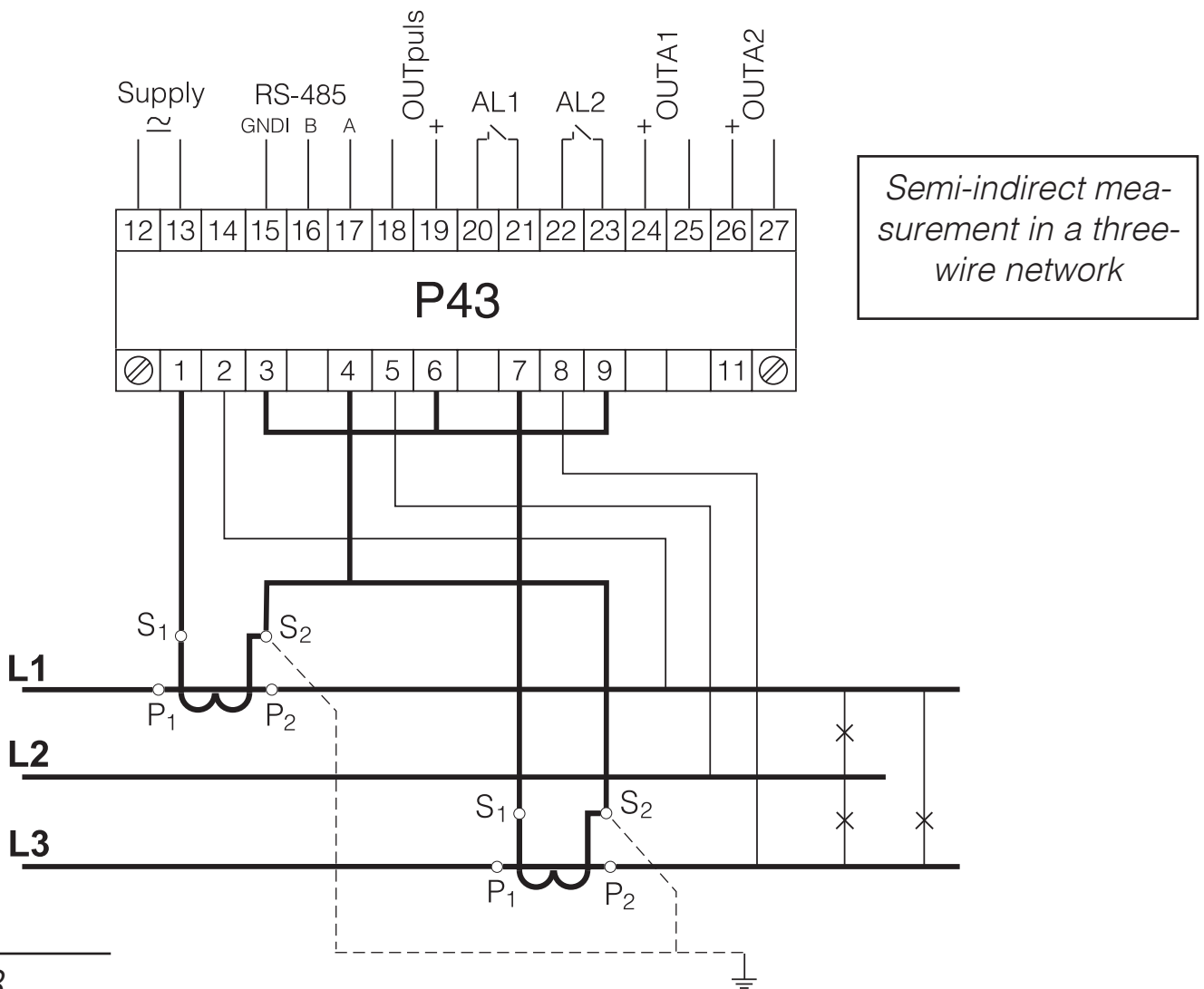
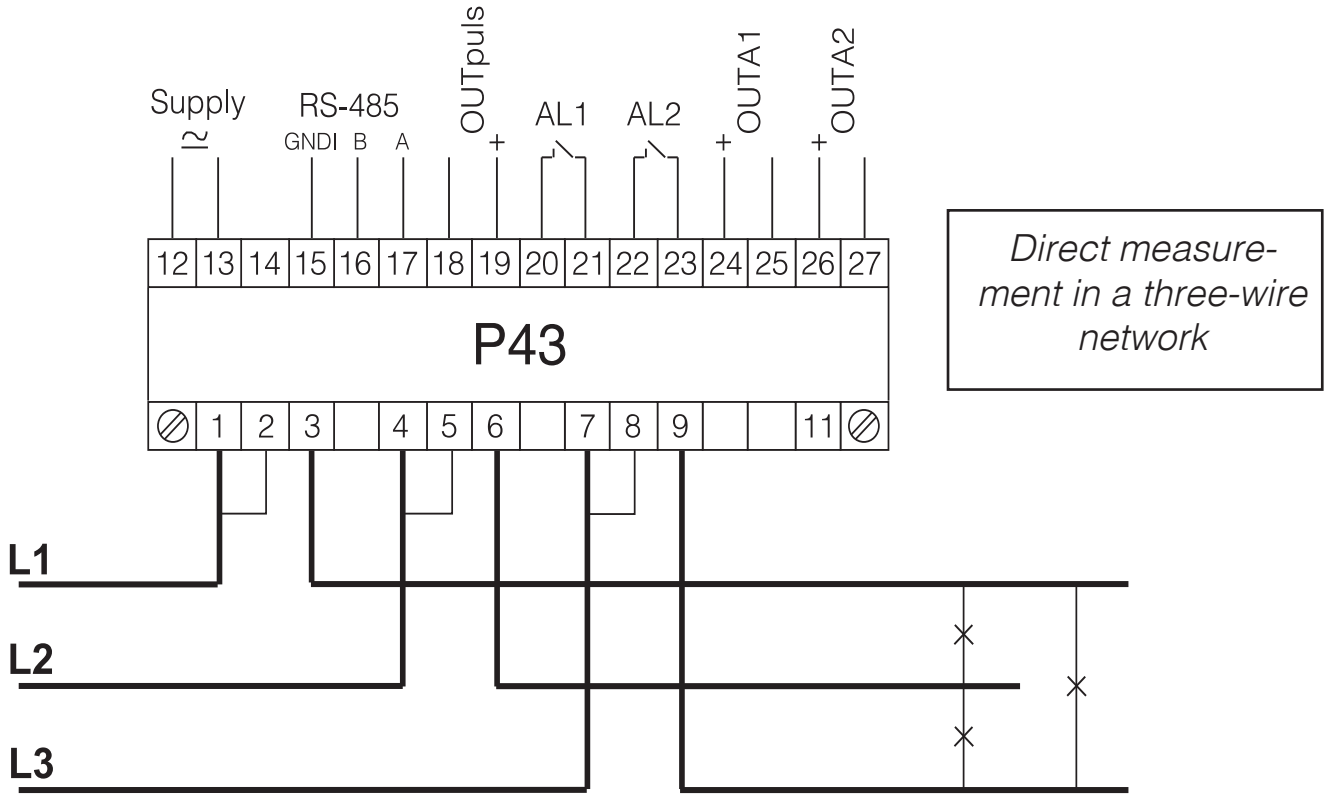
The P43 transducer is adapted to be mounted on a 35 mm rail acc. to EN 60715.

The overall drawing and the fitting way are presented on the fig.1.

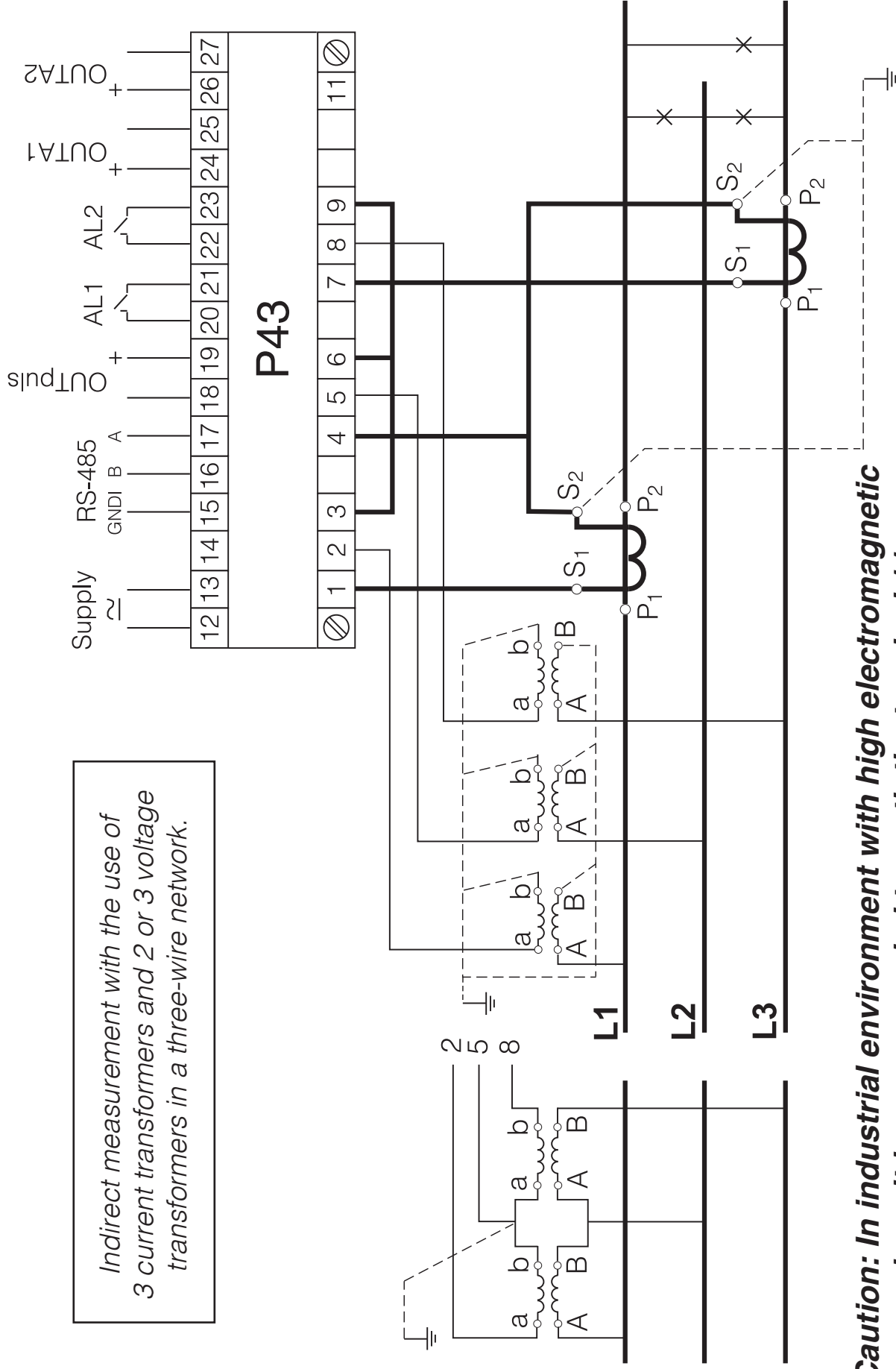


*Fig.1 Overall Dimensions and Transducer Fitting Way.*

## 4.2. External Connection Diagrams

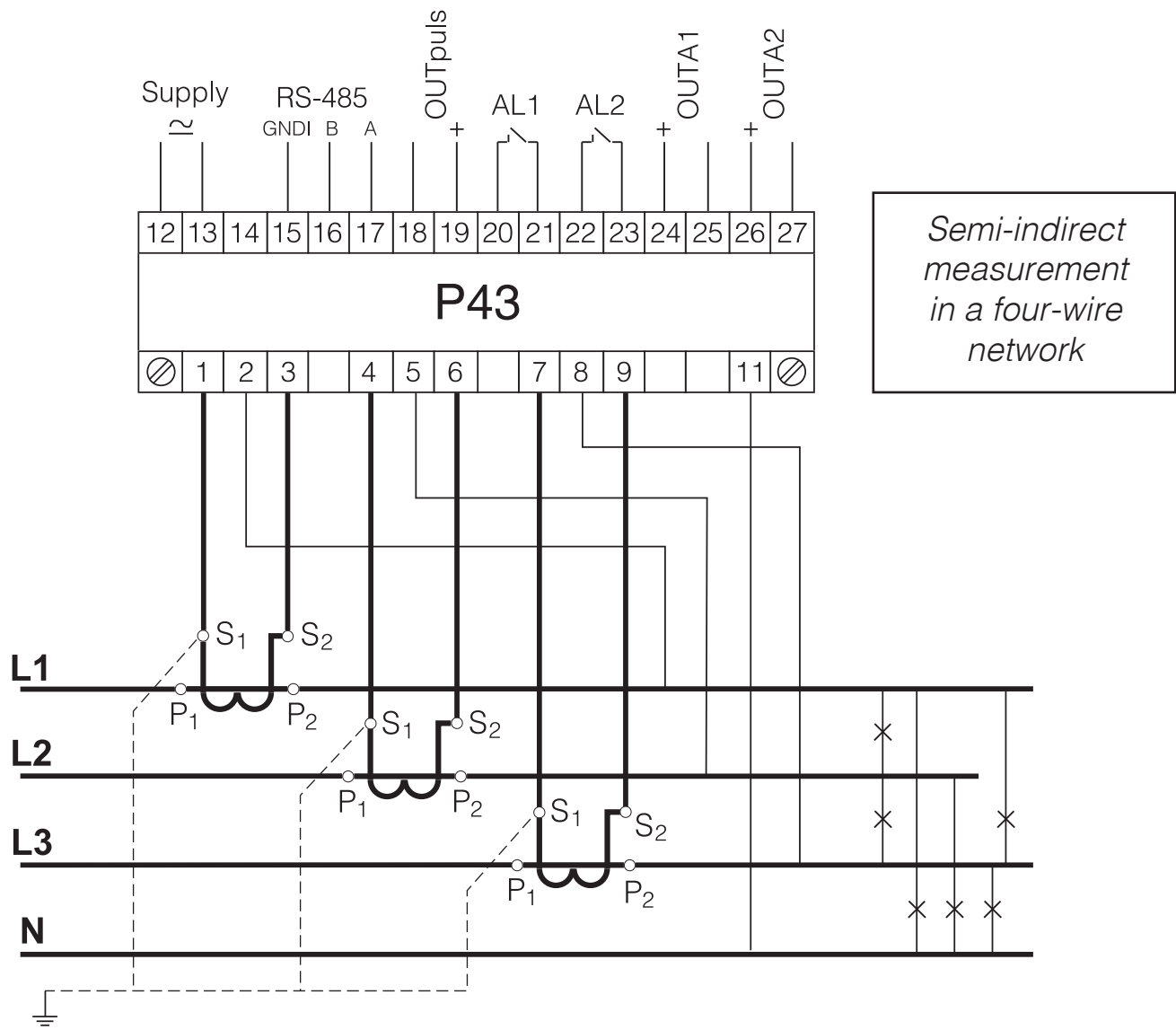
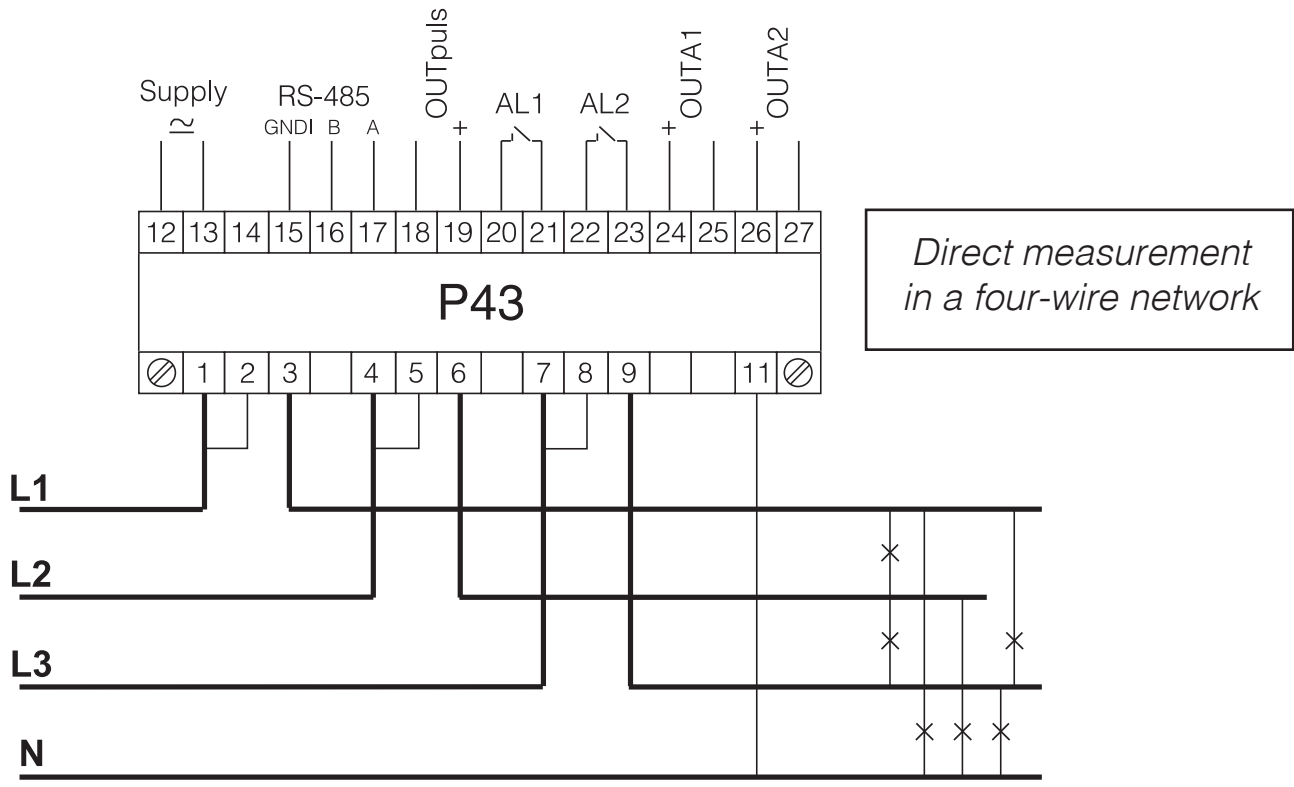


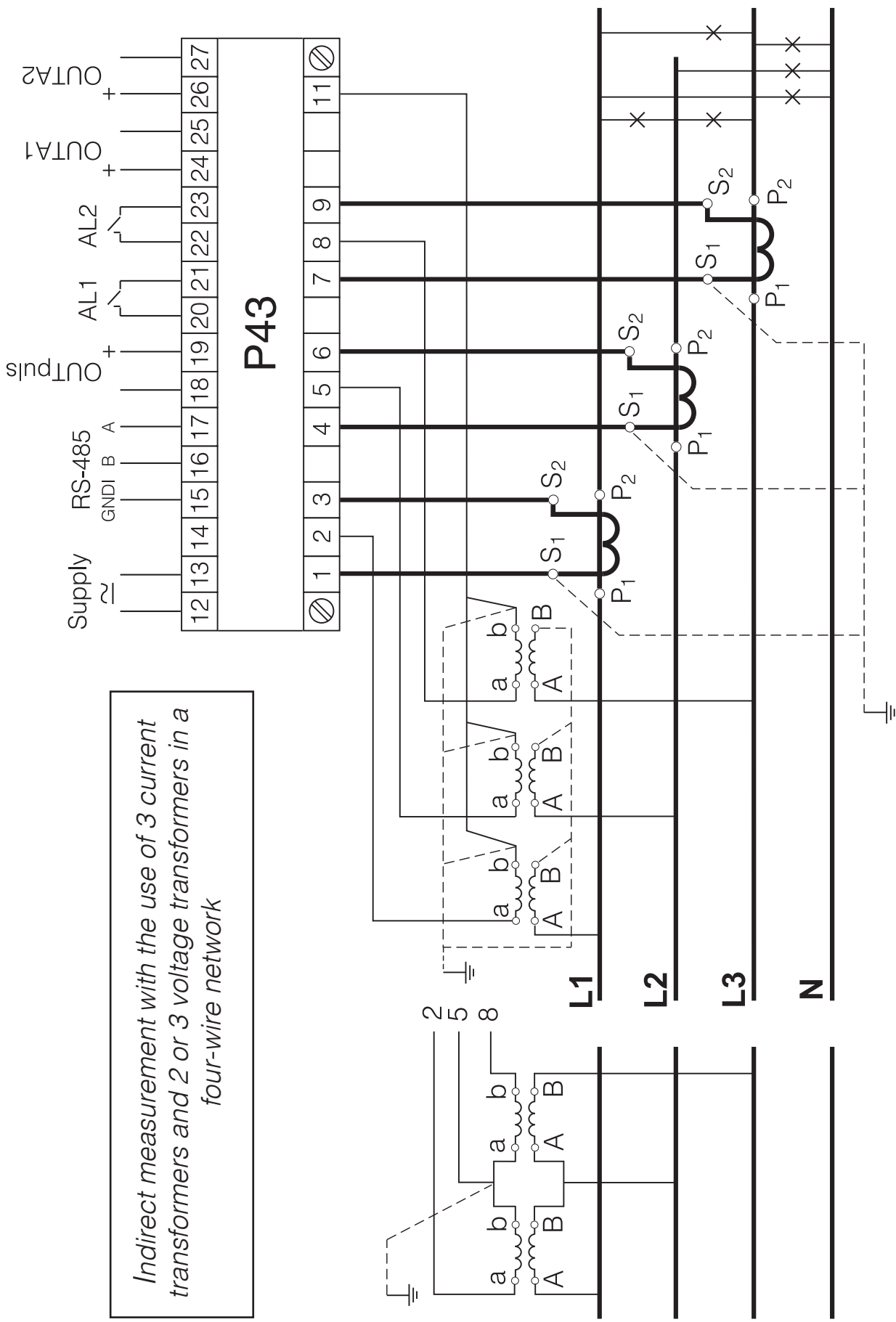
Indirect measurement with the use of 3 current transformers and 2 or 3 voltage transformers in a three-wire network.



**Caution: In industrial environment with high electromagnetic noises, it is recommended to earth the terminal 11.**

Fig. 2. Connection Diagrams of the Transducer in a Three-wire Network





*Indirect measurement with the use of 3 current transformers and 2 or 3 voltage transformers in a four-wire network*

*Fig. 3. Connection Diagrams of the Transducer in a Four-wire Network*

## 5. SERVICE

### Frontal Plate Description

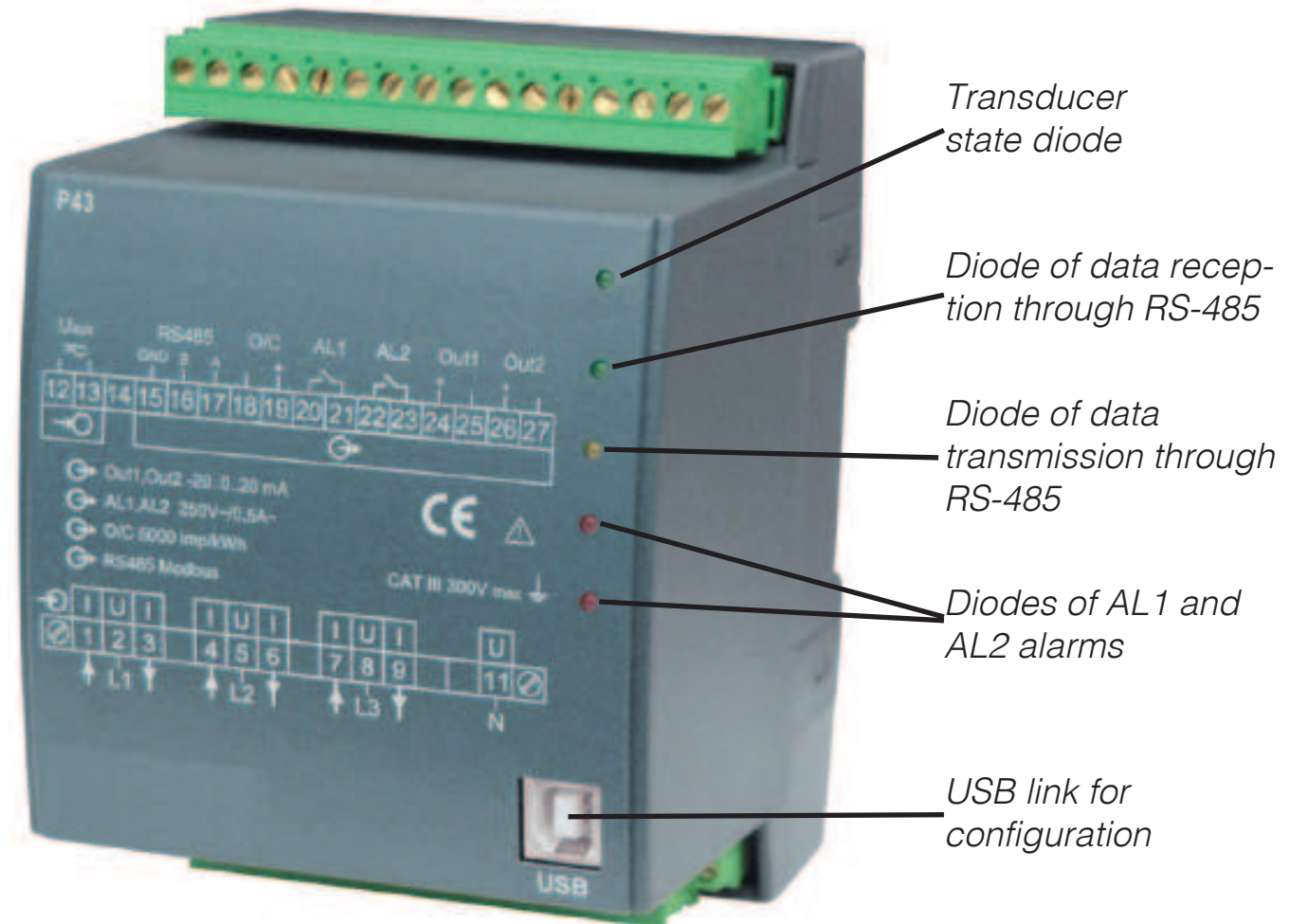


Fig. 4 Frontal view of the P43 transducer

### Messages after Switching the Supply on

After switching the supply on, the state diode should light up for a moment in red, and next should light up in green. The recording confirmation in registers is signaled by a short extinction of the state diode.

The incorrect work is signaled by the state diode in the way described in the chapter 7. The data reception through the RS-485 interface is signaled by a pulsing of the Rx diode. The data transmission through

the RS-485 interface is signaled by a pulsing of the Tx diode.

The switching of the relay 1 on causes the lighting of the AL1 diode, however the switching of the output 2 on causes the lighting of the AL2 diode (fig. 4).

## Installation of COM Port Controllers in the Computer

The P43 transducer makes use of the software, which creates in the system, a device of Universal Serial Bus – **P43 transducer of network parameters**, and connected to it, the virtual COM port named **P43 transducer of network parameters**.

The controller installation in the Windows system causes the addition of a successive serial COM port to the list of ports serviced by the operating system.

After connecting the transducer to the USB port, the operating system informs about the appearance of a new device by means of the message presented on the fig. 5.

The creator to find a new hardware of the Universal Serial Bus will be started automatically. One must act in compliance with the creator suggestions, choosing the installation from the indicated location and giving the path to controllers being in the added CD. Controllers are compatible with following systems: Windows 2000, XP, Server 2003, Vista, server 2008, (x86 and X64). When installing controllers, information about the lack of the controller digital signature can occur. One must ignore this information and carry on the installation.



*Fig. 5. Message signaling the detection of a new device “Transducer of P43 type”.*

After closing the creator, the system detect immediately the successive device – USB Serial Port (fig. 6.). The creator for detection a new hardware will start again.



*Fig. 6. Systemic message concerning the detection of a new device*

After the successful ending of the installation, the system will inform about the installation of a new device (fig. 7.). Two new devices appear in the device manager – **Transducer P43** and Port COM named: **Transducer P43**, acc. to the fig. 8.



*Fig. 7. Systemic message ending the installation of P43 controllers*

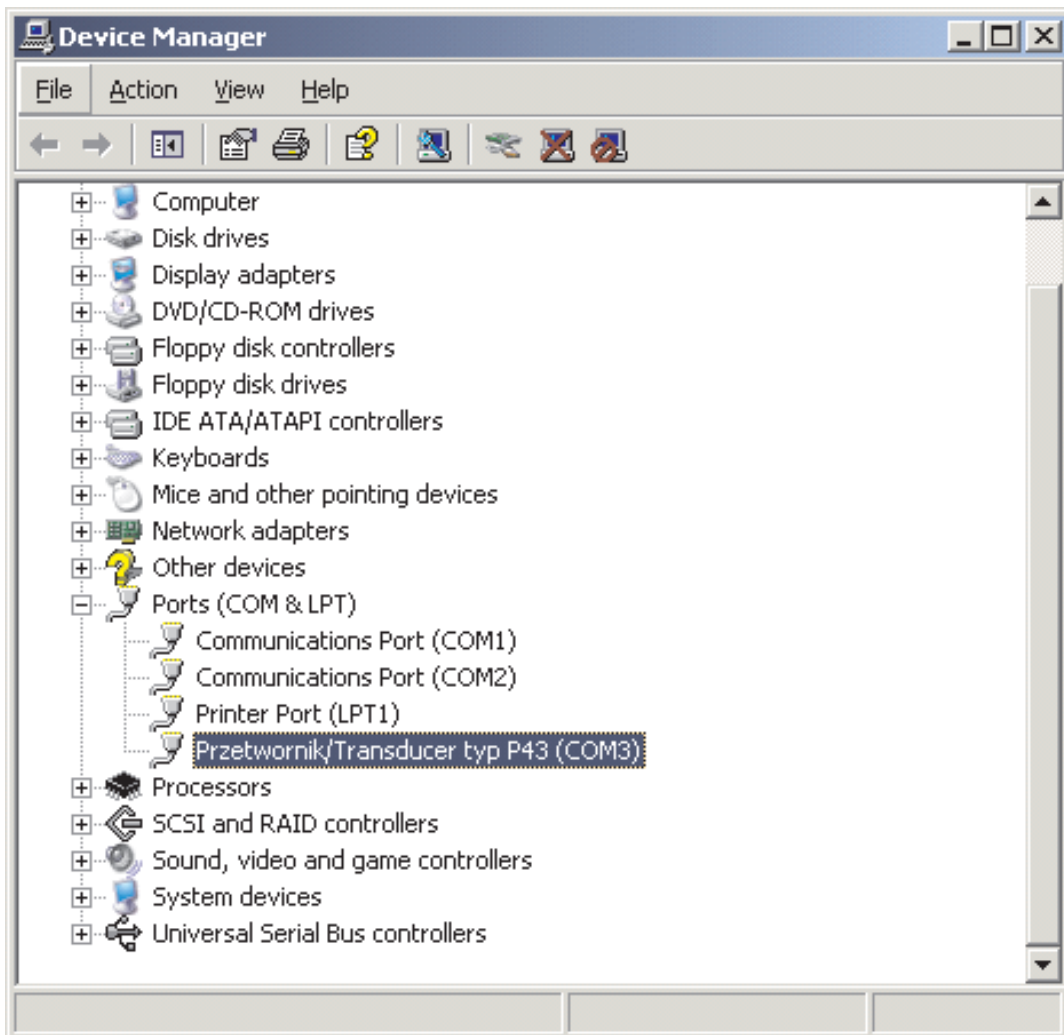
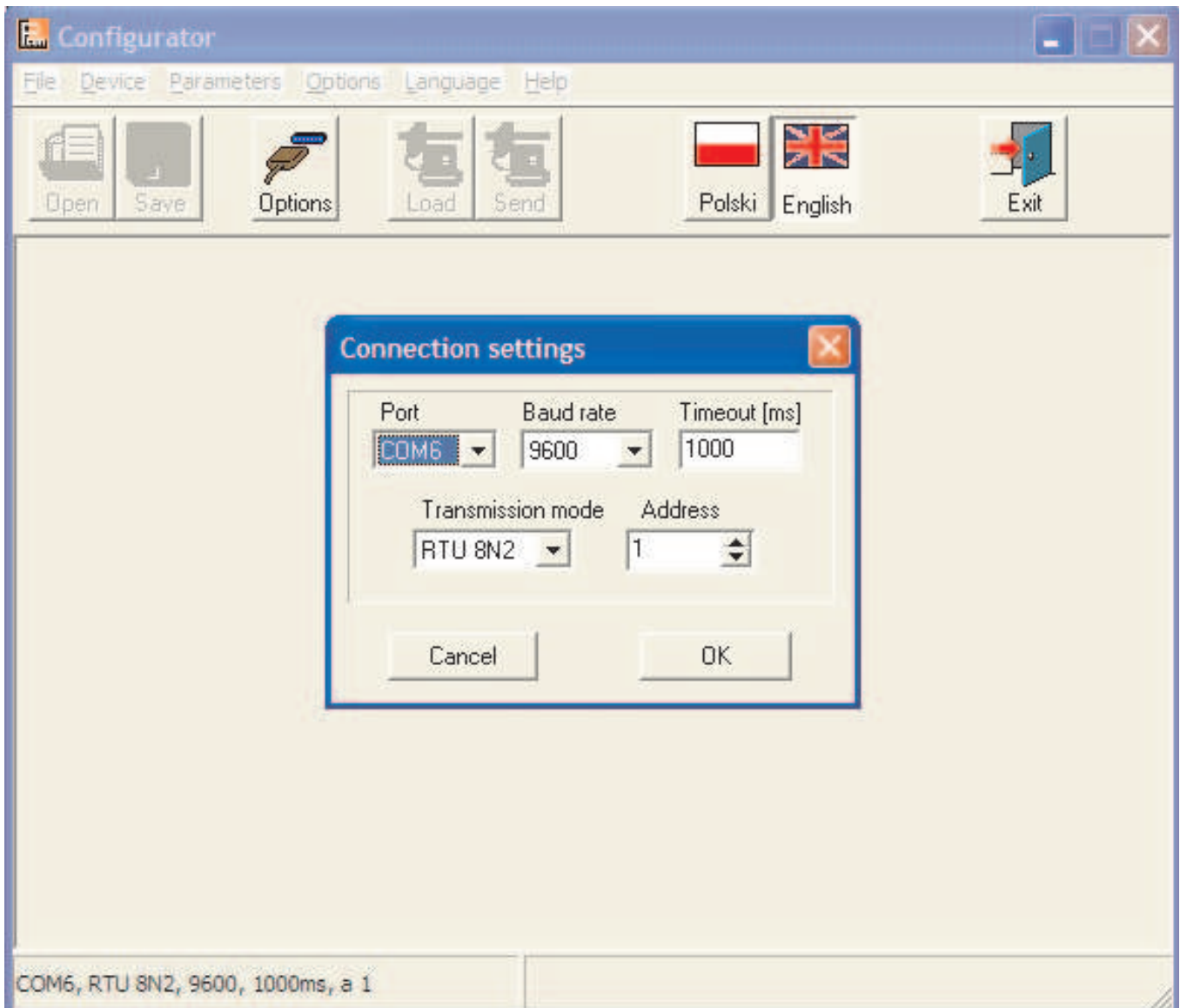


Fig. 8. View of the device manager window together with the installed P43 transducer, which the port COM6 is assigned to.

## Transducer Configuration by Means of the LPCon Software

The LPCon software is destined for the configuration of the P43 transducer. One must connect the transducer to the PC computer through the PD10 converter or directly through the USB link and after choosing the **Option-> Connection configuration**, configure the connection (fig. 9.). For direct connection, through USB: address 1, baud rate 9600 kb/s, mode RTU 8N2, timeout 1000 ms and the suitable COM port under which the controller of the P43 transducer has been installed or through the RS-485 interface and the PD10 programmer: address, baud rate, and the mode acc. to the installed in the transducer.



*Fig. 9. Configuration of the connection with the P43 transducer*

After the connection configuration, one must choose from the **Device -> Transducers -> P43** menu, and next click the **Readout** icon in order to read out all parameters. One can also read out parameters individually in each group, clicking the **Refresh** button. In order to change parameters, one must write the new value in the parameter window and click the **Apply** button.

## Setting of Transmission Parameters

After choosing the group – **transmission parameters**, it is possible to configure following elements:

- address – address for the communication with the P43 transducer through the RS-485 interface from the range 1...247. The value 1 is normally set up by the manufacturer.
- baud rate – the communication rate through the RS-485 interface from the range (4800, 9600, 19200, 38400 bit/sec.) The value 9600 is set up by the manufacturer.
- transmission mode – The transmission mode through the RS485 interface from the range (RTU 8N2, RTU 8E1, RTU 8O1, RTU 8N1). The transmission mode is normally set up on RTU 8N2 by the manufacturer.

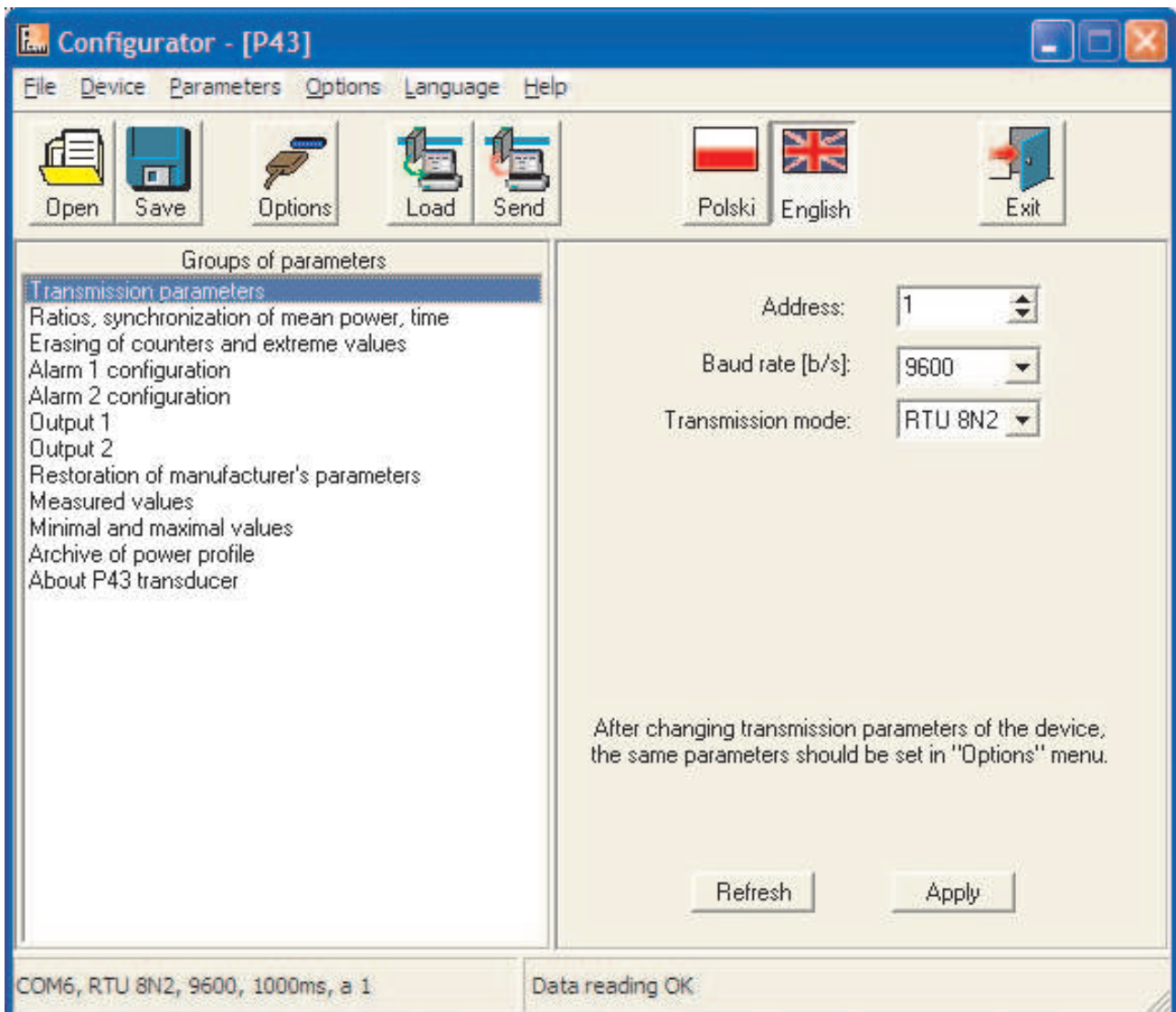


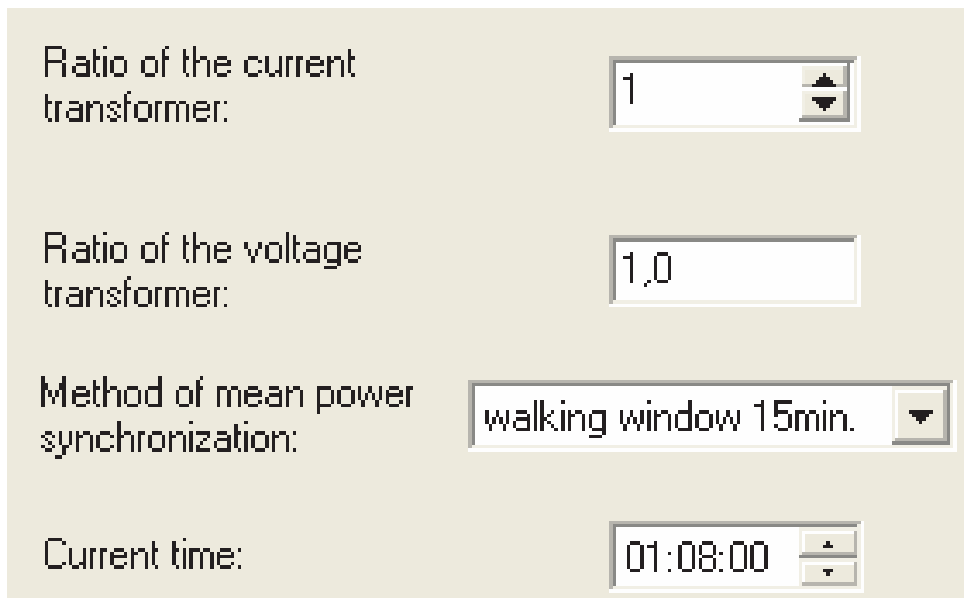
Fig. 10. View of the configuration window of transmission parameters

## Setting of Measurement Parameters

After choosing the group: **ratios, power synchronization, time**, following elements can be configured (fig. 11.):

- a) current transformer ratio. The multiplier is used to recalculate the current in the transformer primary side. It is set up on 1 by the manufacturer.
- b) voltage transformer ratio. The multiplier is used to recalculate the voltage in the transformer primary side. It is set up on 1 by the manufacturer.
- c) way to synchronize the mean power:
  - 15 minutes' walking window – mean power PAV will be recalculated for the last 15 minutes, actualized every 15 seconds, i.e. walking window,
  - measurement synchronized with the clock every 15, 30 or 60 minutes - mean power PAV will be actualized every 15, 30 or 60 minutes synchronized with the external real clock (fig. 12).

It is set up on the walking window by the manufacturer.



Ratio of the current transformer:	1
Ratio of the voltage transformer:	1,0
Method of mean power synchronization:	walking window 15min.
Current time:	01:08:00

Fig.11. View of the configuration window of measurement parameters

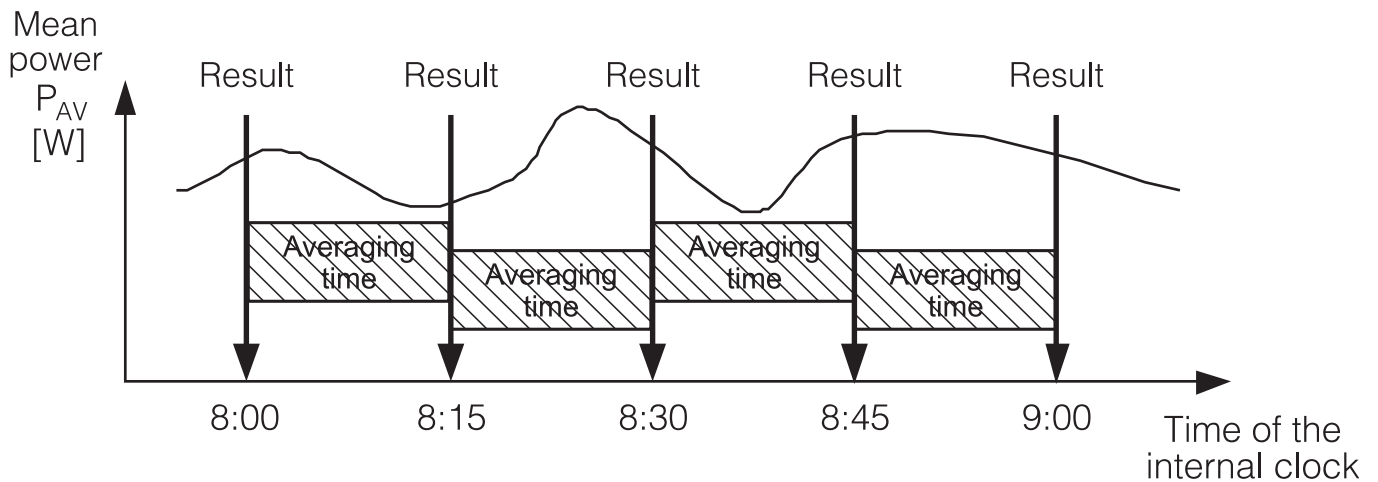


Fig. 12. Measurement of the 15 minutes' active mean power synchronized with the clock.

- d) current time. Time in the form hh:mm:ss. It is set up on 0:00:00 by the manufacturer (also after the supply decay).

## *Erasing of Watt-hour Meters and Extremal Values*

After choosing the group: **erasing of watt-hour meters and extremal Values**, following commands are possible to carry out (fig. 13):

- erasing of watt-hour meters. All watt-hour meters of active and reactive energy are erased,
- erasing of active mean power. The power archive is additionally erased, the number of measurements is set up on 0.
- erasing of min. and max. values. The currently measured value is copied out to the minimal and maximal value.

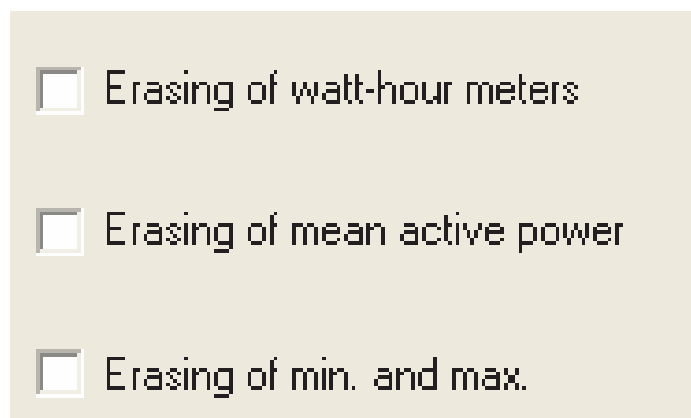


Fig. 13. View of the window to erase watt-hour meters.

## Setting of alarm parameters

After choosing the group: **alarm 1 configuration** or **alarm 2 configuration**, it is possible to configure following alarm parameters (fig. 15):

- a) assignment of the alarm output parameter – kind of signal, on which the alarm acc. to the table 1 has to react,

The set of the input quantity for alarms and analog outputs is included in the table 1. The calculation way is shown in examples in the chapter 9.

Table 1

Value in registers 4010, 4015, 4020, 4026	Kind of quantity	Value for percentage calculation of alarms and output values
00	Lack of quantity /alarm or analog output switched off/	Lack
01	Voltage of phase 1	$U_n$ [V] *
02	Current in the wire of phase L1	$I_n$ [A] *
03	Active power of phase L1	$U_n \times I_n \times \cos(0^\circ)$ [W] *
04	Reactive power of phase L1	$U_n \times I_n \times \sin(90^\circ)$ [var] *
05	Apparent power of phase L1	$U_n \times I_n$ [VA] *
06	Coefficient of active power of phase L1	1
07	Coefficient $\text{tg}\varphi$ of phase L1	1
08	Voltage of phase 2	$U_n$ [V] *
09	Current in the wire of phase L2	$I_n$ [A] *
10	Active power of phase L2	$U_n \times I_n \times \cos(0^\circ)$ [W] *
11	Reactive power of phase L2	$U_n \times I_n \times \sin(90^\circ)$ [var] *
12	Apparent power of phase L2	$U_n \times I_n$ [VA] *
13	Coefficient of active power of phase L2	1
14	Coefficient $\text{tg}\varphi$ of phase L2	1
15	Voltage of phase 3	$U_n$ [V] *
16	Current in the wire of phase L3	$I_n$ [A] *
17	Active power of phase L3	$U_n \times I_n \times \cos(0^\circ)$ [W] *
18	Reactive power of phase L3	$U_n \times I_n \times \sin(90^\circ)$ [var] *

19	Apparent power of phase L3	$U_n \times I_n$ [VA] *
20	Coefficient of active power of phase L3	1
21	Coefficient $\text{tg}\phi$ of phase L3	1
22	3-phase mean voltage	$U_n$ [V] *
23	3-phase mean current	$I_n$ [A] *
24	3-phase active power (P1+P2+P3)	$3 \times U_n \times I_n \times \cos(0^\circ)$ [W] *
25	3-phase reactive power (Q1+Q2+Q3)	$3 \times U_n \times I_n \times \sin(90^\circ)$ [var] *
26	3-phase reactive power (S1+S2+S3)	$3 \times U_n \times I_n$ [VA] *
27	Power factor of 3-phase active power	1
28	3-phase coefficient $\text{tg}\phi$	1
29	Frequency	100 [Hz]
30	Phase-to-phase voltage L1-L2	$\sqrt{3} U_n$ [V] *
31	Phase-to-phase voltage L2-L3	$\sqrt{3} U_n$ [V] *
32	Phase-to-phase voltage L3-L1	$\sqrt{3} U_n$ [V] *
33	Phase-to-phase voltage mean voltage	$\sqrt{3} U_n$ [V] *
34	15, 30, 60 minutes' 3-phase active power	$3 \times U_n \times I_n \times \cos(0^\circ)$ [W] *

\*  $U_n, I_n$  – Rated values of transducer voltage and current

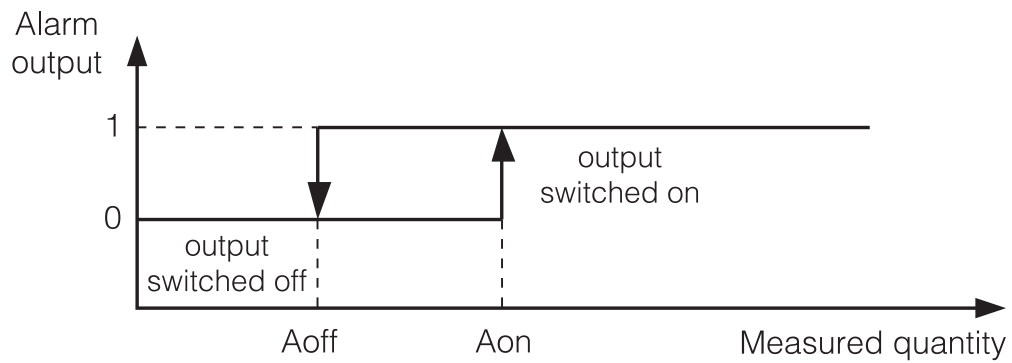
- b) kind of the alarm output operation – choose one from 6 modes n-on, n-off, on, off, h-on and h-off. Working modes have been presented on the fig. 14,
- c) lower value of alarm switching – percentage value of the state change of the chosen signal,
- d) upper value of alarm switching – percentage value of the state change of the chosen signal,
- e) switching delay of the alarm. Delay time in seconds when switching the alarm state

Both alarms are set up in the mode n-on.

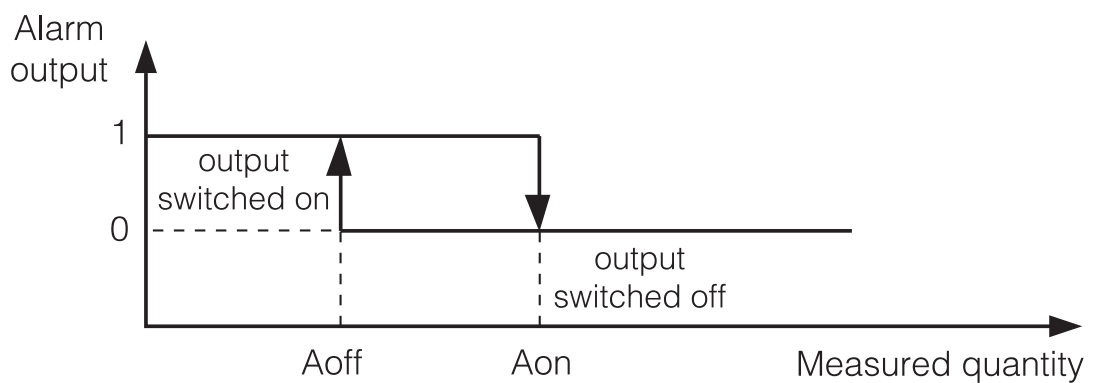
**Caution! The setup of the value  $A_{off} \geq A_{on}$  causes the alarm switching off.**

Exemplary configuration of alarm 1 and 2 is presented on the fig. 15.

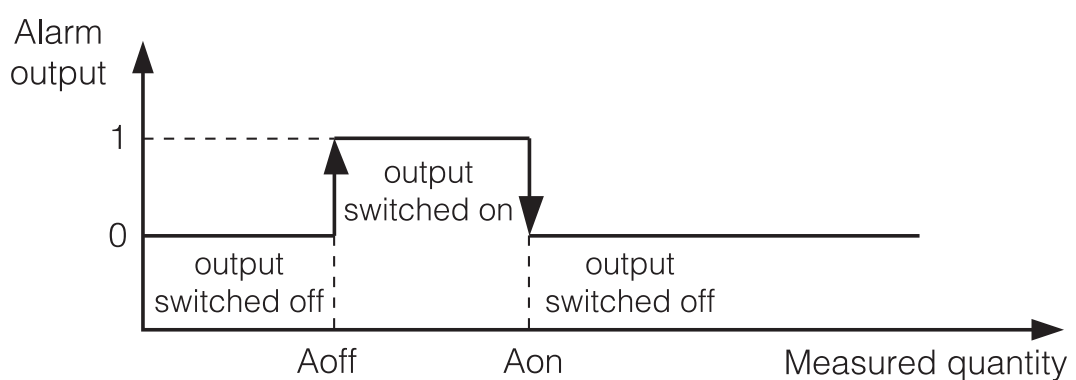
**a) n-on**



**b) n-off**



**c) on**



**d) off**

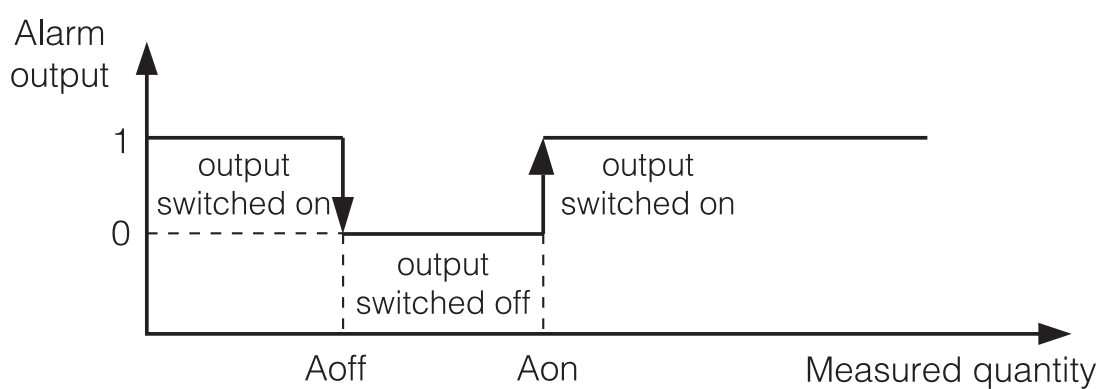


Fig. 14. Alarm types: a) n-on, b) n-off c) on d) off.

Other alarm types: h-on – always switched on; h-off – always switched off.

Assigning a measuring value to the alarm output:

3-phase active power

Output type: n-on

Upper value of alarm switching [%]: 101,0

Lower value of alarm switching [%]: 99,0

Delay of alarm switching [s]: 0

Fig. 15. View of the configuration window of analog output

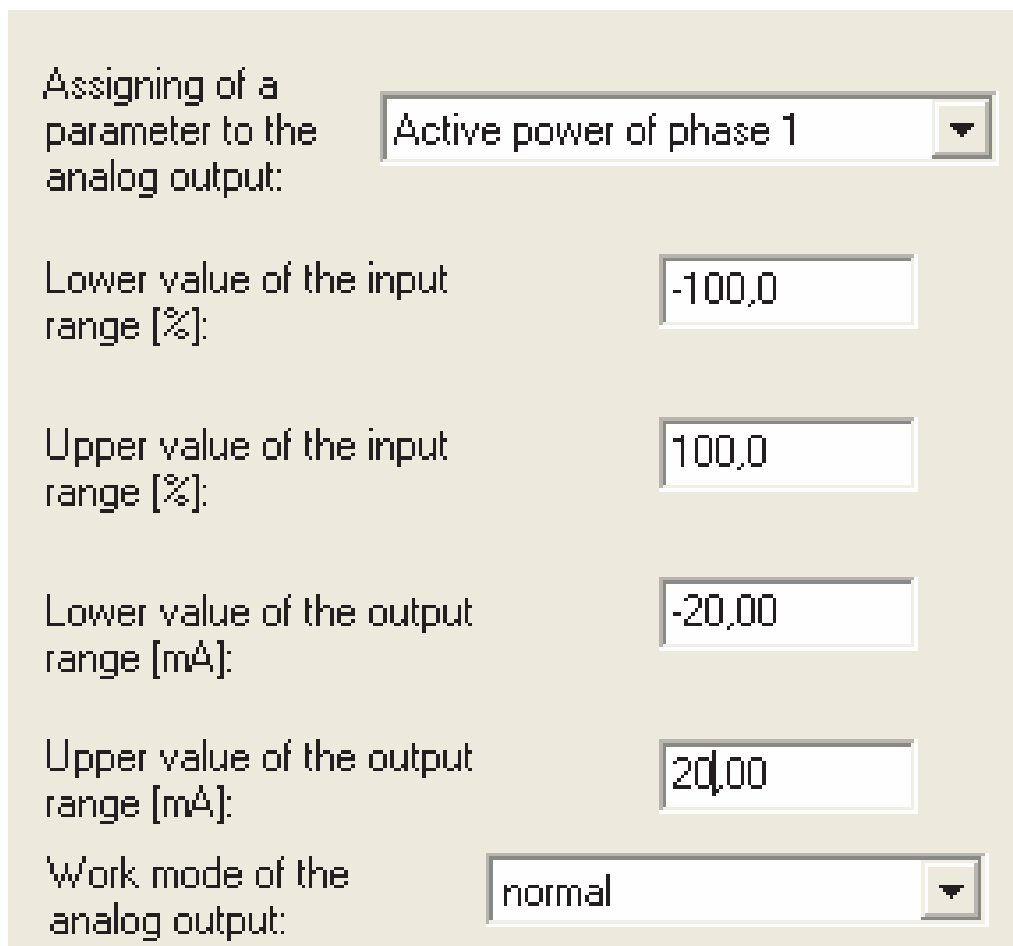
## ***Setup of analog output parameters***

After choosing the group: **output 1** or **output 2**, it is possible to configure following output parameters:

- a) assignment of the parameter to the analog output. Kind of signal, on which the output has to react acc. to the table 1,
- b) lower value of the input range. Percentage value of the chosen signal,
- c) upper value of the input range. Percentage value of the chosen signal,
- d) lower value of the output range. Output signal value in mA,
- e) upper value of the output range. Output signal value in mA,

- f) working mode of the analog output. Following modes are accessible: normal work lower value, upper value. Both alarms are set up in the normal mode by the manufacturer.

An exemplary configuration of the analog output is presented on the fig. 16.e).



The screenshot shows a configuration window with the following fields and values:

Assigning of a parameter to the analog output:	Active power of phase 1
Lower value of the input range [%]:	-100,0
Upper value of the input range [%]:	100,0
Lower value of the output range [mA]:	-20,00
Upper value of the output range [mA]:	20,00
Work mode of the analog output:	normal

Fig. 16. View of the analog output configuration window

Admissible overflow on the analog output: 20% of the lower and upper range value.

Minimal value on the analog output:  $-20 \times 1.2 = -24$  mA.

Maximal value on the analog output:  $20 \times 1.2 = 24$  mA.

## ***Restoration of Manufacturer Parameters***

After choosing the group: **restoration of manufacturer parameters** it is possible to restore following manufacturers parameters set in the table 2:

Table 2

<b>Parameter description</b>	<b>Range/value</b>	<b>Manufacturer value</b>
Ratio of the current transformer	1...10000	1
Ratio of the voltage transformer	1...4000	1.0
Synchronization of the active mean power:	<ul style="list-style-type: none"> <li>- 15 minutes' walking window (recording in the archive every 15 minutes)</li> <li>- measurement synchronized with the clock every 15 minutes,</li> <li>- measurement synchronized with the clock every 30 minutes,</li> <li>- measurement synchronized with the clock every 60 minutes,</li> </ul>	walking window
Hour x100 + Minutes	0:00...23:59	0:00
Quantity on the relay output No 1	0...34 (acc. to the table 1)	24
Output type of the alarm 1	n-on; n-off; on; off; h-on; h-off;	n-on
Lower value of the alarm 1 switching	-120.0...120.0%	99.0%
Upper value of the alarm 1 switching	-120.0...120.0%	101.0%
Switching delay of the alarm 1	0...300 sekund	0
Quantity on the relay output No 2	0...34 (acc. to the table 1)	23
Output type of the alarm 2	n-on; n-off; on; off; h-on; h-off;	n-on
Lower value of the alarm 2 switching	-120.0...120.0%	99.0%
Upper value of the alarm 2 switching	-120.0... 120.0%	101.0%

Switching delay of the alarm 2	0...300	0
Quantity on the continuous No 1	0...34 (acc. to the table 1)	24
Lower value of the input range in % of the rated range of the input No 1	-120.0...120.0%	0.0%
Upper value of the input range in % of the rated range of the input No 1	-120.0...120.0%	100.0%
Lower value of the output range of the output No 1	-20.00...20.00 mA	4.00 mA
Lower value of the output range of the output No 1	0.01...20.00 mA	20.00 mA
Manual switching of the analog output 1 on:	normal work, the lower value of the output range No 1 is set up the upper value of the output range No 1 is set up.	normal work
Quantity on the continuous No 2	0...34 (acc. to the table 1)	23
Lower value of the input range in % of the rated range of the input No 2	-120.0...120.0%	0.0%
Upper value of the input range in % of the rated range of the input No 2	-120.0...120.0%	120.0%
Lower value of the output range of the output No 2	-20.00...20.00 mA	0 mA

Upper value of the output range of the output No 2	0.01...20.00 mA	20 mA
Manual switching of the analog output 2:	normal work, the lower value of the output range No 2 is set up, the upper value of the output range No 2 is set up.	normal work
Address in the MOD-BUS network	1... 247	1
Transmission mode	8n2, 8e1, 8o1, 8n1	8n2
Baud rate	4800, 9600, 19200, 38400	9600

## Measured Values

After choosing the group: - **measured values**, all parameters measured by the transducer are displayed in the form of a list (fig. 17.).

Parameter	Value
Mean minimal 3-phase voltage	229,92 V
Mean maximal 3-phase voltage	9198,44 V
Mean minimal 3-phase current	3,197 A
Mean maximal 3-phase current	319,71 A
Minimal 3-phase active power	2204,061 W
Maximal 3-phase active power	8817099 W
Minimal 3-phase reactive power	- 6,172 Var
Maximal 3-phase reactive power	1,811 Var
Minimal 3-phase apparent power	2205,419 VA
Maximal 3-phase apparent power	8822500 VA
Minimal active power factor	1
Maximal active power factor	1

Fig. 17. View of the window of the measured value group

## Minimal and Maximal Values

After choosing the group: - **minimal and maximal values**, minimal and maximal values of individual parameters measured by the transducer in the form of a list are displayed (fig. 18.).

Parameter	Value
Mean minimal 3-phase voltage	229,92 V
Mean maximal 3-phase voltage	9198,44 V
Mean minimal 3-phase current	3,197 A
Mean maximal 3-phase current	319,71 A
Minimal 3-phase active power	2204,061 W
Maximal 3-phase active power	8817099 W
Minimal 3-phase reactive power	- 6,172 Var
Maximal 3-phase reactive power	1,811 Var
Minimal 3-phase apparent power	2205,419 VA
Maximal 3-phase apparent power	8822500 VA
Minimal active power factor	1
Maximal active power factor	1

Fig. 18. View of the window of the min. and max. value group

## Archive of power profile

After choosing the group: - **archive of power profile**, following information is displayed:

archiving frequency – frequency time to store the value of averaged power (sample), number of samples, from which sample to display from the range 1...961 (fig. 19).

Archive of Mean Active Power	
Archive period:	15 min.
Number of samples:	4
Reading 40 samples from No.:	1
Sample No.	Mean Power
1	3380,482 W
2	3442,557 W
3	3442,604 W
4	3442,8 W
5	-----
6	-----
7	-----
8	-----
9	-----
10	-----

Fig. 19. View of the window of the power profile archive group

The detailed description of archive operation is described in chapter 6.

## Information about the Device

After choosing the group – **information about the device**, following information is displayed: The device picture, serial number, program version, and a short device description



Factory No: 0809002  
Firmware version: 0.80

Fig. 20. View of the window of the information about the device group

## 6. Archive – Power Profile

---

The P43 transducer is equipped with an archive allowing to store up to 1000 measurements of averaged active power. The averaged active power  $P_{AV}$  can be archived with time intervals 15, 30, 60 minutes synchronized with the real time clock (0, 15, 30, 45 minutes – an example for 15 minutes is shown on the fig.11).

In case of work in the mode: 15 minutes' walking window, the archiving is the same as for the 15 minutes' time interval (fig. 12). The archive is available in the form of 1001 registers in the range of addresses 8000-9000.

The number of archived values is in the register 8000, however values (samples) are archived in registers with addresses 8001-9000. Values 1e20 are in registers, in which samples are not written yet.

The archive is organized in the shape of a circular buffer. After writing the thousandth value, the next value overwrites the oldest value with the number 1, and successively the next with the number 2, etc.

As long as the number of samples does not exceed 1000, the value in the register 8000 indicates the number of archived samples. After exceeding 1000 samples, the number of archived values changes in the range from 1000 to 2000. E.g. the value 1006 in the register 8000 means, that there was more than a thousand of samples and the oldest samples are from the register 8007 to 9000, next from 8001 to the youngest sample located in the register 8006.

The change of the current or voltage transformer ratio, real time or the kind of mean power causes the archive erasing.

## 7. Error Codes

---

After connecting the transducer to the network, messages about errors can appear. Causes of errors are presented below:

- the state diode pulsates in red – lack of calibration or the non-volatile memory is damaged. One must return the transducer to the manufacturer,
- the state diode lights in red – inappropriate work parameters; one must configure the transducer again.
- the state diode pulsate alternately in red and green - error of phase connection sequence; one must interchange the connection of phase L2 with the phase L3.

## 8. Serial Interfaces

---

### 8.1. RS-485 Interface – Set of Parameters

- identifier 0xB4 (180)
- transducer address 1...247
- baud rate 4.8, 9.6, 19.2, 38.4 kbit/s
- working mode Modbus RTU
- information unit 8N2, 8E1, 8O1, 8N1
- maximal response time 1000 ms
- maximal number of bytes during the readout/write: 200 bytes
- implemented functions 03, 16, 17
  - 03 readout of registers,
  - 16 write of registers,
  - 17 device identifying.

Manufacturer's settings: address 1, baud rate 9600, mode RTU 8N2.

### 8.2. USB Interface – Set of Parameters

- identifier 0xB4
- transducer address 1
- baud rate 9.6 kbit/s
- working mode Modbus RTU
- information unit 8N2
- maximal response time 1000 ms
- maximal number of bytes during the readout/write: 200 bytes
- implemented functions 03, 16, 17
  - 03 readout of registers,
  - 16 write of registers,
  - 17 device identifying.

### 8.3. Register Map of the P43 Transducer

In the P43 transducer, data are located in 16-bit and 32-bit registers. Process variables and transducer parameters are located in the register address space in the way depending on the type of the variable

value type. Bits in 16-bit register are numbered in the way depending on the variable value type. Bits in 16-bit registers are numbered from the younger to the older (b0-b15). 32-bit registers contain numbers of float type in the IEEE-745 standard. Register ranges are set in the table 3. 16-bit registers are presented in the table 4. 32-bit registers are set in tables 5 and 6. Register addresses in tables 3,4,5,6 are physical addresses.

Table 3

Range of addresses	Type of value	Description
1000 – 3001	Float (2x16 bits)	Value located in two successive 16-bit registers. Registers contain the same data as 32-bit registers from the area 8000. Registers only for readout.
4000 – 4044	Integer (16 bits)	Value located in one 16-bit register. The table 3 contains the register description. Registers for write and readout.
7000 – 7121	Float (2x16 bits)	Value located in two successive 16-bit registers. Registers contain the same data as 32-bit registers from the area 7500. Registers for readout.
7500 – 7560	Float (32 bits)	Value located in one 32-bit register. The table 4 contains the description of registers. Registers for readout.
8000 – 9000	Float (32 bits)	Value located in one 32-bit register. The table 6 contains the description of registers. Registers for readout.

Table 4

Register address	Operations	Range	Description	By Default
4000	RW	0	Reserved	0
4001	RW	0	Reserved	0
4002	RW	0	Reserved	0
4003	RW	1...10000	Current transformer ratio	1
4004	RW	1...40000	Voltage transformer ratio x 0.1	10

4005	RW	0...3	Synchronization of mean active power: 0 – 15 minutes' walking window (recording synchronized every 15 min with the clock.) 1 – measurement synchronized every 15 min with the clock. 2 – measurement synchronized every 30 min with the clock. 3 – measurement synchronized every 60 min with the clock.	0
4006	RW	0.1	Erasing of energy watt-hour meters	0
4007	RW	0.1	Erasing of mean active power $P_{AV}$	0
4008	RW	0.1	Erasing min and max	0
4009	RW	0...2359	Hour x100 + Minutes	0
4010	RW	0.1..34	Quantity on the relay output No 1 /code acc. to the table 1/	0
4011	RW	0..5	Output type: 0 – n-on, 1– n-off, 2 – on, 3 - oFF, 4 – h-on, 5 – h-oFF	0
4012	RW	-1200..0..1200 [‰]	Lower switching value of the alarm No 1 (relay)	990
4013	RW	-1200..0..1200 [‰]	Upper switching value of the alarm No 1 (relay)	1010
4014	RW	0..300 s	Switching delay of the alarm 1	0
4015	RW	0.1..34	Quantity on the relay output No 2 (code acc. to the table 1)	0
4016	RW	0..5	Output type: 0 – n-on, 1– n-off, 2 – on, 3 - oFF, 4 – h-on, 5 – h-oFF	0
4017	RW	-1200...0...1200 [‰]	Lower switching value of the alarm No 2 (relay)	990
4018	RW	-1200...0...1200 [‰]	Upper switching value of the alarm No 2 (relay)	1010
4019	RW	0...300 s	Switching delay of the alarm 2	0
4020	RW	0.1...34	Quantity on the continuous output No 1 (code acc. to the table 1)	0
4021	RW	-1200...0...1200 [‰]	Lower value of the input range in [‰] of the rated input range No 1	0

4022	RW	-1200...0...1200 [‰]	Upper value of the input range in [‰] of the rated input range No 1	1200
4023	RW	-2000...0...2000 [10 µA]	Lower value of the output range of the output No1 [10 µA]	400
4024	RW	1...2000 [10 µA]	Upper value of the output range of the output No1	2000
4025	RW	0...2	Manual switching on of the analog output 1: 0 – normal work, 1 – value set from the register 4023, 2- value made from the register 4024	0
4026	RW	0.1...34	Quantity on the continuous output No 2 (code acc. to the table 1)	0
4027	RW	-1200...0...1200 [‰]	Lower value of the input range in [‰] of the rated range of the input No 2	0
4028	RW	-1200...0...1200 [‰]	Upper value of the input range in [‰] of the rated range of the input No 2	1200
4029	RW	-2000...0...2000 [10 µA]	Lower value of the output range of the output No 2 [10 µA]	400
4030	RW	1...2000 [10 µA]	Upper value of the output range of the output No 2 [10µA]	2000
4031	RW	0..2	Manual switching on of the analog output 2: 0 – normal work, 1 – value set from the register 4029, 2- value set from the register 4030	0
4032	RW	1...247	Address in the MODBUS network	1
4033	RW	0...3	Transmission mode: 0->8n2, 1->8e1,2->8o1, 3->8n1	0
4034	RW	0...3	Baud rate: 0->4800, 1->9600 2->19200, 3->38400	1
4035	RW	0,1	Update the change of transmission parameters	0
4036	RW	0,1	Record of standard parameters	0
4037	R	0...15258	Active input energy, two older bytes*	0

4038	R	0...65535	Active input energy, two younger bytes*	0
4039	R	0...15258	Reactive inductive energy, two older bytes*	0
4040	R	0...65535	Reactive inductive energy, two younger bytes*	0
4041	R	0...65535	Status register – description below	0
4042	R	0...65535	Serial number, two older bytes*	0
4043	R	0...65535	Serial number, two younger bytes*	0
4044	R	0...65535	Program version (x 100)	100
4045	R	0...15258	Active energy output, two older bytes*	0
4046	R	0...65535	Active energy output, two younger bytes*	0
4047	R	0...15258	Reactive capacitive energy, two older bytes*	0

\* available from the program version 1.02. In prior versions, registers 4037- 4040 include energies from added modules of particular energies.

In parenthesis [ ]: resolution or unit is suitably placed.

Energies are render accessible in hundreds of Watt-hours (Var-hours) in two 16-bit registers and for this reason when recalculating values of each energy from registers, one must divide them by 10, i.e:

Active input energy = (value of register.4034 \* 65536 + value of register 4038) / 10 [kWh]

Active output energy = (value of register.4045 \* 65536 + value of register 4046) / 10 [kWh]

Reactive inductive energy = (value of register 4039 \* 65536 + value of register 4040) / 10 [kVarh]

Reactive capacitive energy = (value of register 4047 \* 65536 + value of register 4048) / 10 [kVarh]

Status register:

Bit 15 – „1” – damage of non-volatile memory

Bit 14 – „1” – lack of calibration or erroneous calibration

Bit 13 – „1” – error of parameter values

Bit 12 – „1” – error of energy values

Bit 11 – „1” – reserved

Bit 10 – current range „0” – 1 A~; 1” – 5 A~

Bit 9	Bit 8	Voltage range
0	0	57,8 V~
0	1	230 V~

Bit 7 – „1” – the interval of power averaging is not elapsed

Bit 6 – „1” – reserved

Bit 5 – „1” – too low voltage to measure the frequency

Bit 4 – „1” – too little voltage of phase C

Bit 3 – „1” – too little voltage of phase B

Bit 2 – „1” – too little voltage of phase A

Bit 1 – relay output state „2” – On, „0” - off

Bit 0 – relay output state „1” – On, „0” - off

Table 5

Ad- dress of 16 bit regi- sters	Ad- dress of 16 bit regi- sters	Ope- ra- tions	Description	Unit
7000	7500	R	Voltage of phase L1	V
7002	7501	R	Current of phase L1	A
7004	7502	R	Active power of phase L1	W
7006	7503	R	Reactive power of phase L1	Var
7008	7504	R	Apparent power of phase L1	VA
7010	7505	R	Active power factor of phase L1	-
7012	7506	R	Reactive power to active power ratio of phase L1	-
7014	7507	R	Voltage of phase L2	V

7016	7508	R	Current of phase L2	A
7018	7509	R	Active power of phase fazy L2	W
7020	7510	R	Reactive power of phase L2	Var
7022	7511	R	Apparent power of phase L2	VA
7024	7512	R	Active power factor of phase L2	-
7026	7513	R	Reactive power to active power ratio of phase L2	-
7028	7514	R	Voltage of phase L3	V
7030	7515	R	Current of phase L3	A
7032	7516	R	Active power of phase fazy L3	W
7034	7517	R	Reactive power of phase L3	Var
7036	7518	R	Apparent power of phase L3	VA
7038	7519	R	Active power factor of phase L3	-
7040	7520	R	Reactive power to active power ratio of phase L3	-
7042	7521	R	Mean 3-phase voltage	V
7044	7522	R	Mean 3-phase current	A
7046	7523	R	3-phase active power (P1+P2+P3)	W
7048	7524	R	3-phase reactive power (Q1+Q2+Q3)	Var
7050	7525	R	3-phase apparent power (S1+S2+S3)	VA
7052	7526	R	Mean active power factor	-
7054	7527	R	Mean ratio of reactive power to active power	-
7056	7528	R	Frequency	Hz
7058	7529	R	Phase-to-phase voltage L1-L2	V
7060	7530	R	Phase-to-phase voltage L2-L3	V
7062	7531	R	Phase-to-phase voltage L3-L1	V
7064	7532	R	Mean phase-to-phase voltage	V
7066	7533	R	15, 30, 60 minutes' 3-phase act. power (P1+P2+P3)	W
7068	7534	R	Reserved	
7070	7535	R	Reserved	
7072	7536	R	Min. mean 3-phase voltage	V
7074	7537	R	Max. mean 3-phase voltage	V

7076	7538	R	Min. mean 3-phase current	A
7078	7539	R	Max. mean 3-phase current	A
7080	7540	R	Min. 3-phase active power	W
7082	7541	R	Max. 3-phase active power	W
7084	7542	R	Min. 3-phase reactive power	Var
7086	7543	R	Max. 3-phase reactive power	Var
7088	7544	R	Min. 3-phase apparent power	VA
7090	7545	R	Max. 3-phase apparent power	VA
7092	7546	R	Min. active power factor	-
7094	7547	R	Max. active power factor	-
7096	7548	R	Min. mean ratio of reactive power to active power	-
7098	7549	R	Max. mean ratio of reactive power to active power	-
7100	7550	R	Min. frequency	Hz
7102	7551	R	Max. frequency	Hz
7104	7552	R	Min. mean phase-to-phase voltage	V
7106	7553	R	Max. mean phase-to-phase voltage	V
7108	7554	R	Min. mean active power	W
7110	7555	R	Max. mean active power	W
7112	7556	R	3-phase active energy (number of register 7557 overfills), setting to zero after exceeding 99999999.9 kWh)*	100 MWh
7114	7557	R	3-phase active input energy (watt-hour-meter counting to 99999.9 kWh)*	kWh
7116	7558	R	3-phase reactive inductive energy (number of register 7559 overfills), setting to zero after exceeding 99999999.9 kVarh)*	100 MVarh
7118	7559	R	3-phase reactive inductive energy (watt-hour meter counting to 99999.9 kVarh)*	kVarh
7120	7560	R	Steering up the analog output 1	%
7122	7561	R	Steering up the analog output 2	%
7124	7562	R	Time – hours, minutes	hh, mm

7126	7563	R	3-phase active output energy (number of register 7564 overfills, setting to zero after exceeding 99999999.9 kWh)*	100 MWh
7128	7564	R	3-phase active output energy (number of register 7566 overfills, setting to zero after exceeding 99999999.9 kVarh)*	kWh
7130	7565	R	3-phase reactive capacitive energy (number of register 7564 overfills, setting to zero after exceeding 99999999.9 kWh)*	100 MVarh
7132	7566	R	3-phase reactive capacitive energy (watt-hour-meter counting to 99999.9 kVarh)*	kVarh
7134	7567	R	Shift angle between voltage and current of phase 1*	o
7136	7568	R	Shift angle between voltage and current of phase 2*	o
7138	7569	R	Shift angle between voltage and current of phase 3*	o

\* available from the program version 1.02.

In case of a lower overflow, the value  $-1e20$  is written in, however in case of an upper overflow or if an error occurs, the value  $1e20$  is written in.

Table 6

Address of 16 bit registers	Address of 32 bit registers	Operations	Description
1000	8000	R	Number of archived values
1002	8001	R	Archived value with number 1
1004	8002	R	Archived value with number 2
...	...	...	...
3000	9000	R	Archived value with number 1000

## 9. Examples of P43 Transducer Programming

### Example 1 – Programming an Alarm with Hysteresis

Program the operation of the alarm 1 in such a way, that at the value 250 V of the phase 1 voltage, the alarm will be switched on, however switched off at the value 210 V.

For the rated 230 V execution, one must set up values from the table 7.

Table 7

Register	Value	Meaning
4010	1	1 – voltage of phase 1
4011	0	0 – n-on mode
4012	913	913 – 91.3% (percentage value with one place after the decimal point multiplied by 10) of the rated voltage of phase 1 – alarm switched off, $(210 \text{ V}/230 \text{ V}) \times 1000 = 913$
4013	1087	1087 – 108.7 % (percentage value with one place after the decimal point multiplied by 10) of the rated voltage of phase 1 – alarm switched on, $(250 \text{ V}/230 \text{ V}) \times 1000 = 1087$
4014	0	0 – 0 second delay in the alarm switching

## Example 2 – Programming a Unidirectional Continuous Output

Program the continuous output 1 operation in such a way that, at the value 4 A of the mean three-phase current, the value 20 mA was on the output, however at the value 0 A of the mean three-phase current, the value 4 mA was on the output.

For the rated execution 5 A, one must set values from the table 8.:

Table 8

Register	Value	Meaning
4020	23	23 – mean 3-phase current (I)
4021	0	0 – 0.0% (percentage value with one place after the decimal point multiplied by 10) the lower value of the rated mean 3-phase current, (0 A/5 A) x 1000 = 0
4022	800	800 – 80.0 % (percentage value with one place after the decimal point multiplied by 10) the upper value of the rated mean 3-phase current, (4 A/5 A) x 1000 = 800
4023	400	400 – 4.00 mA (value in mA with two places after the decimal point multiplied by 100) lower value of the output current
4024	2000	2000 – 20.00 mA (value in mA with two places after the decimal point multiplied by 100) upper value of the output current. (20.00 mA x 100) = 2000
4025	0	0 – normal mode of the continuous output 1

## Example 3 – Programming a Bidirectional Continuous Output

Program the continuous output 1 operation in such a way that, at the three-phase power value  $3 \times 4 \text{ A} \times 230 \text{ V} \times \cos(180^\circ) = -2760 \text{ W}$ , the value  $-20 \text{ mA}$  was on the output, however for the three-phase power value  $3 \times 4 \text{ A} \times 230 \text{ V} \times \cos(0^\circ) = 2760 \text{ W}$ , the value  $-20 \text{ mA}$  was on the output.

For the rated execution 3 x 5 /230 V, one must set values from the table 9

Table 9

Register	Value	Meaning
4020	24	24 – 3-phase power (P)
4021	-800	-100 – -100.0% (percentage value with one place after the decimal point multiplied by 10) the lower value of the rated 3-phase power, $(3 \times 4 \text{ A} \times 230 \text{ V} \times \cos (180^\circ))/3 \times 5 \text{ A} \times 230 \text{ V} \times 1000 = - 800$
4022	800	1000 – 100.0% (percentage value with one place after the decimal point multiplied by 10) the upper value of the rated 3-phase power, $(3 \times 4 \text{ A} \times 230 \text{ V} \times \cos (0^\circ))/3 \times 5 \text{ A} \times 230 \text{ V} \times 1000 = 800$
4023	-2000	-2000 – -20.00 mA (value in mA with two places after the decimal point multiplied by 100) lower value of the output current. $(20.00 \text{ mA} \times 100) = -2000$
4024	2000	2000 – 20.00 mA (value in mA with two places after the decimal point multiplied by 100) upper value of the output current. $(20.00 \text{ mA} \times 100) = 2000$
4025	0	0 – normal mode of the continuous output 1

# 10. TECHNICAL DATA

## Measuring Ranges and Admissible Basic Errors

Table 10

Measured quantity	Measuring range	L1	L2	L3	$\Sigma$	Basic error
Current 1/5A L1...L3	0.02... 6 A~	●	●	●		±0.2%
Voltage L-N	2.9... 276 V~	●	●	●		±0.2%
Voltage L-L	10... 480 V~	●	●	●		±0.5%
Frequency	45.0... 100.0 Hz	●	●	●		±0.2%
Active power	-1.65 kW... 1.4 W... 1.65 kW	●	●	●	●	±0.5%
Reactive power	-1.65 kvar... 1.4 var... 1.65 kvar	●	●	●	●	±0.5%
Apparent power	1.4 VA... 1.65 kVA	●	●	●	●	±0.5%
Tangens $\varphi$	-1.2... 0... 1.2	●	●	●	●	±1%
PF factor	-1... 0... 1	●	●	●	●	±0.5%
Angle between U and I	-180°... 180°	●	●	●		±0.5%
Input active energy	0... 99 999 999.9 kWh				●	±0.5%
Developed active energy	0... 99 999 999.9 kWh				●	±0.5%
Reactive inductive energy	0... 99 999 999.9 kvarh				●	±0.5%
Reactive capacitive energy	0... 99 999 999.9 kvarh				●	±0.5%

### Power Consumption:

- in supply circuit  $\leq 6$  VA
- in voltage circuit  $\leq 0,05$  VA
- in current circuit  $\leq 0,05$  VA

### Analog Outputs:

2 programmable outputs:  
 -20...0...+20 mA,  $R_{obc}$ : 0..500 W  
 accuracy 0.2%

### Relay Outputs:

2 relays, voltageless NO contacts  
 load capacity 250 V/ 0,5 A

<b>Serial Interface:</b>	RS-485: address 1...247; mode: 8N2, 8E1, 8O1, 8N1; baud rate: 4.8, 9.6, 19.2, 38.4 kbit/s, <b>USB:</b> 1.1 / 2.0, address 1; mode 8N2; baud rate 9.6 kbit/s,
<b>Transmission Protocol:</b>	Modbus RTU
<b>Energy Pulse Output:</b>	output of OC type, passive acc. to EN 62053-31
<b>Pulse Constant of OC Type Output:</b>	5000 imp./kWh, independently on set ratios $K_u$ , $K_i$
<b>Ratio of the Voltage Transformer <math>K_u</math>:</b>	1... 4000
<b>Ratio of the Current Transformer <math>K_i</math>:</b>	1...10000
<b>Protection Degree:</b>	
- for the housing	IP 40
- from terminals (rear side)	IP 10
<b>Weight:</b>	0,3 kg
<b>Dimensions:</b>	90 x 120 x 100 mm
<b>Fixing Way:</b>	on a 35 mm DIN rail
<b>Reference and Rated Operating Conditions:</b>	
- supply voltage	85...253 V d.c./a.c. 40...400 Hz or 20...40 V d.c./a.c. 40...400 Hz
- input signal	$0...0,005...1,2 I_n$ ; $0...0,05...1,2 U_n$ for current, voltage $0...0,1...1,2 I_n$ ; $0...0,1...1,2 U_n$ for power factors $P_{fi}$ , $t\phi_i$ frequency <u>45...66...100</u> Hz sinusoidal (THD $\leq 8\%$ )

- power factor	-1...0...1
- analog outputs	-24...-20...0...+20...24 mA
- ambient temperature	-10...23...+55°C
- storage temperature	-30...+70°C
- relative humidity	25...95% (inadmissible condensation)
- admissible peak factor:	
- current	2
- voltage	2
- external magnetic field	0...40...400 A/m
- short duration overload 5 sec.	
- voltage inputs	2Un (max. 1000 V)
- current inputs	10 In
- work position	any
- preheating time	5 min.

### **Additional errors:**

in percentage of the basic error:

- from frequency of input signals	< 50%
- from ambient temperature changes	< 50%/10°C
- for THD > 8%	< 100%

### **Standards Fulfilled by the Meter**

#### ***Electromagnetic Compatibility:***

● noise immunity	acc. to EN 61000-6-2
● noise emission	acc. to EN 61000-6-4

#### ***Safety Requirements:***

According to EN 61010-1 standard

● isolation between circuits	basic
● installation category	III,
● pollution level	2,
● maximal phase-to-earth voltage	300 V
● altitude above sea level	< 2000 m,

# 11. EXECUTION CODES

Table 11

TRANSDUCER	P43 -	X	X	X	XX	X
<b>Current input In:</b>						
1 A (X/1) .....						<b>1</b>
5 A (X/5) .....						<b>2</b>
<b>Voltage input (phase/phase-to-phase) Un:</b>						
3 × 57,7/100 V .....						<b>1</b>
3 × 230/400 V .....						<b>2</b>
<b>Supply voltage:</b>						
85...253 V a.c./d.c. ....						<b>1</b>
20...40 V a.c./d.c. ....						<b>2</b>
<b>Kind of execution:</b>						
standard .....						<b>00</b>
custom-made .....						<b>XX</b>
<b>Acceptance tests:</b>						
without extra quality requirements .....						<b>8</b>
with an extra quality inspection certificate .....						<b>7</b>
acc. to customer's requirements* .....						<b>X</b>

\* After agreeing with the manufacturer

### **Example of Order:**

When ordering please respect successive code numbers.

The code: **P43 - 2 2 1 00 8** means:

- P43** – transducer of network parameters of P43 type
- 2** – current input  $I_n$  : 5 A (x/5),
- 2** – input voltage (phase/phase-to-phase)  $U_n = 3 \times 230/400$  V,
- 1** – supply voltage: 85...253 V a.c./d.c.
- 00** – standard execution,
- 8** – execution without extra quality requirements.

## 12. Maintenance and Guarantee

---

The P43 transducer does not require any periodical maintenance.

In case of some incorrect operations:

### **After the dispatch date and in the period stated in the guarantee card:**

One should return the instrument to the Manufacturer's Quality Inspection Dept. If the instrument has been used in compliance with the instructions, we guarantee to repair it free of charge.

The disassembling of the housing causes the cancellation of the granted guarantee.

### **After the guarantee period:**

One should turn over the instrument to repair it in a certified service workshop.

**Our policy is one of continuous improvement and we reserve the right to make changes in design and specifications of any products as engineering advances or necessity requires and revise the above specifications without notice.**





## **SALES PROGRAM**

- DIGITAL and BARGRAPH PANEL METERS
- MEASURING TRANSDUCERS
- ANALOG PANEL METERS (DIN INSTRUMENTS)
- DIGITAL CLAMP-ON METERS
- INDUSTRIAL PROCESS and POWER CONTROLLERS
- CHART and PAPERLESS RECORDERS
- 1-PHASE and 3-PHASE WATT-HOUR METERS
- LARGE SIZE DISPLAY PANELS
- ELEMENTS OF INTEGRATION SYSTEMS
- ACCESSORIES for MEASURING INSTRUMENTS (SHUNTS)
- CUSTOM-MADE PRODUCTS ACCORDING CUSTOMER'S REQUIREMENTS

## **MEASUREMENT CONTROL RECORDING**

### ***WE ALSO OFFER OUR SERVICES IN THE PRODUCTION OF:***

- ALUMINIUM ALLOY PRESSURE CASTINGS
- PRECISION ENGINEERING and THERMOPLASTICS PARTS
- SUBCONTRACTING of ELECTRONIC DEVICES (SMT)
- PRESSURE CASTINGS and OTHER TOOLS

### ***QUALITY PROCEDURES:***

***According to ISO 9001 and ISO 14001 international requirements.***

All our instruments have CE mark.

For more information, please write to or phone our Export Department



**Lubuskie Zakłady Aparatów Elektrycznych LUMEL S.A.**

ul. Sulechowska 1, 65-022 Zielona Góra, Poland

Tel.: (48-68) 329 51 00 (exchange)

Fax: (48-68) 329 51 01

e-mail: [lumel@lumel.com.pl](mailto:lumel@lumel.com.pl)

<http://www.lumel.com.pl>

**Export Department:**

Tel.: (48-68) 329 53 02

Fax: (48-68) 325 40 91

e-mail: [export@lumel.com.pl](mailto:export@lumel.com.pl)