



**ELECTRONIC SINGLE-PHASE
WATT-HOUR METER
WITH DIGITAL COMMUNICATION
LS1.1 TYPE**



USER'S MANUAL



CONTENTS

1. APPLICATION	5
2. BASIC INFORMATION	5
3. WATT-HOUR-METER SET	6
4. WATT-HOUR METER DESIGN	6
5. INSTALLATION	7
5.1. <i>External dimensions and fixing way</i>	7
5.2. <i>Connection diagrams</i>	9
6. DISPLAYED INFORMATION	10
6.1. <i>View of LCD display</i>	10
6.2. <i>Displayed energy</i>	11
6.3. <i>LED pulse output</i>	11
6.4. <i>Signalling of phase voltage presence</i>	11
6.5. <i>Signalling of the active tariff (time zone)</i>	11
6.6. <i>Signalling of energy counting</i>	11
6.7. <i>Signalling of review, parameter programming or interference with a magnetic field</i>	11
6.8. <i>Signalling of housing opening (interference in the watt-hour meter)</i>	12
6.9. <i>Signalling of extra information</i>	12
7. CHANGE OF WATT-HOUR METER CONFIGURATION	12
7.1. <i>Button</i>	12
7.2. <i>Way of configuration parameter change</i>	13
8. ENERGY MEASUREMENT	19
8.1. <i>Recording of energy in tariffs</i>	19
8.2. <i>Recording of total energy</i>	19
9. POWER REGISTERS	19
9.1. <i>Averaged maximal power</i>	19
9.2. <i>Cumulated power</i>	19
10. END OF THE ACCOUNTING PERIOD	19
11. AVAILABLE TARIFF GROUPS	20
11.1. <i>Tariff group G11</i>	20
11.2. <i>Tariff group G12</i>	20
11.3. <i>Tariff group G12w</i>	20
11.4. <i>Tariff group G13</i>	20
11.5. <i>Tariff group C12a</i>	21
11.6. <i>Tariff group C12b</i>	21
11.7. <i>Tariff group C12w</i>	21
11.8. <i>Tariff group C22a</i>	22
11.9. <i>Tariff group C22b</i>	22
11.10. <i>List of holidays</i>	20

12. OPTICAL INTERFACE	22
12.1. Watt-hour meter registers in readout mode	23
12.2. Watt-hour meter registers in programming and readout mode	26
13. RS-485 OR RS-232 SERIAL INTERFACE WITH MODBUS PROTOCOL (OPTION).....	27
13.1. List of serial interface parameters.....	27
13.2. Map of watt-hour meter registers.....	28
14. INTERNAL CONTROL CLOCK (for options with external clock)	32
15. TECHNICAL DATA	32
16. VERSION CODES.....	34
17. MAINTENANCE AND WARRANTY.....	35

1. APPLICATION

LS1.1 electronic watt-hour meters are destined for the direct measurement of active energy in single-phase power networks with the simultaneous display of measured quantities.

They can be applied for settlement of accounts with electric power plants, for industrial process control, for settlement of accounts with sub-hirers.

These watt-hour meters are designed to be mounted on a wall.

The housing enables to set a legalization leaden seal on the watt-hour meter cover and a leaden seal of the energy supplier on the terminal box.

Thanks to built-in communication interfaces, they can be applied as an element of energy management systems.

These watt-hour meters have a 7-digit LCD display with additional graphic symbols. As standard, there is also a lighting and pulsing red diode (LED) and interface for data transmission in infrared.

2. BASIC INFORMATION

LS1.1 electronic watt-hour meters are resistant to a strong external magnetic field, e.g. a neodymium magnet.

A special designed antitheft protection has been applied in the mechanical construction, in the electronic system and in the software.

Protection of the construction

- The frontal cover, having on the whole perimeter, internal and external projections enclosing bilaterally and tightly the base wall, unabling the interference with a tool inside the watt-hour meter.
- The cover is fixed to the base by two screws, what gives a durable junction secured additionally by leaden seals.
- The shield of the terminal box additionally presses down the cover and protects the fixing screws by leaden seals.
- The junction of the cover and the base is sealed, what protects against the infiltration of fluids and dust.

Electronic and programmed protection

- Sensor of mechanical interference in the watt-hour meter. The lift of the watt-hour meter frontal cover causes the sensor operation, and the existed interference is signalled on the display. Additionally, the date and the interference duration are stored in the watt-hour meter memory.
- Sensor of the interaction by a strong magnetic field, e.g. a neodymium magnet. The application of a strong magnetic field to the watt-hour meter causes the sensor operation, and the existed interference is signalled on the display.
- The number of mechanical interference and interactions by a magnetic field is durably recorded in the watt-hour meter.

Protection against the switching of power network wires

The watt-hour meter counts the energy when interchanging network wires. The energy is accounted regardless of the flow direction. The shield of the terminal box can be optionally made of a transparent plastics enabling a visual inspection of the electrical connection correctness with the user (energy receiver).

The watt-hour meter equipment with a communication interface or a radio transmitter gives the possibility of a permanent monitoring, data archiving, visualization and report.

The LS1.1 watt-hour meter can be included into existing computer networks, what is rendered possible by offered interface and protocol converters produced by LUMEL.

3. WATT-HOUR METER SET

The set of the watt-hour meter is composed of:

- LS1.1 watt-hour meter 1 pc
- User's manual 1 pc
- Warranty card 1 pc

4. WATT-HOUR METER DESIGN

The construction of the LS1.1 watt-hour meter is presented on the fig. 1.

The watt-hour meter housing is made of an insulated material (lexan) and ensures the service safety in the protection class II.

The review and setting of watt-hour meter parameters are realized by the button (4) situated in the shield (8). The button is adapted to be sealed with lead. After sealing the button, there is possible to review selected data on the display.

The function of parameter setting is accessible after removing the leaden seal and turning the button.

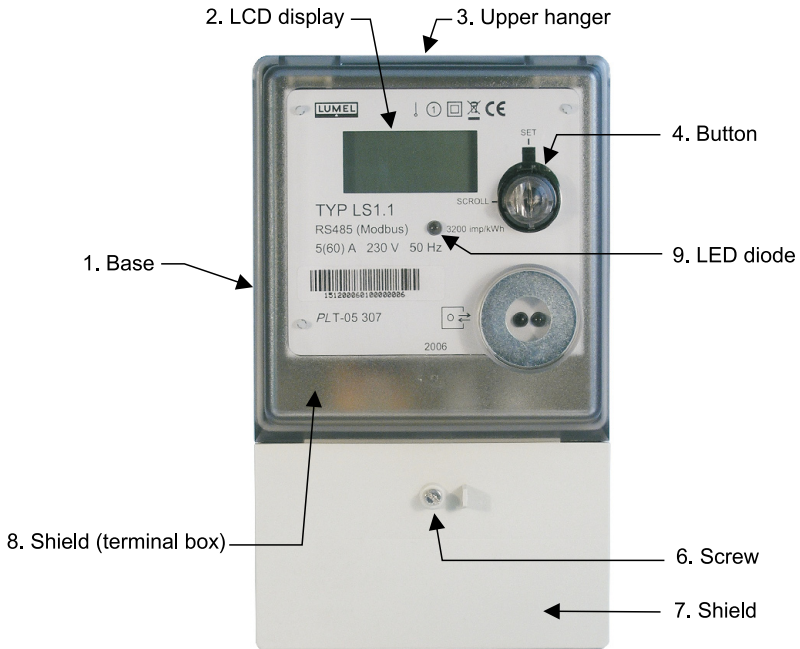

Fig. 1a Watt-hour meter design - view of the watt-hour meter with the fixed terminal box shield (7)

1. Base
2. 7-digit liquid crystal display (LCD) with graphical symbols
3. Upper hanger - metallic element fixing the watt-hour meter to the power box or the watt-hour meter niche
4. Two-function button - review and setting of watt-hour meter parameters
5. Optical link - enables the readout and write of data from and to the watt-hour meter
6. Screw - fixes the shield (7) and is adapted to seal with lead by the power plant
7. Shield of the terminal box
8. Shield of the watt-hour meter - It is fixed to the base by internal catches and two screws (10)
9. LED diode - generates light pulses with a defined time-constant (imp/kWh)

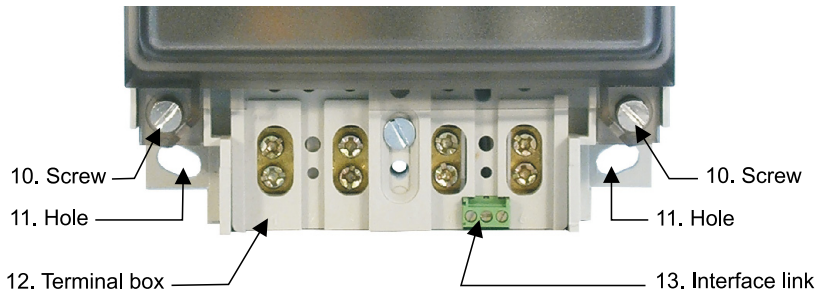

Fig. 1b Watt-hour meter design - View of terminals after removing the terminal shield (7)

10. Fixing screws - to fix the shield (8), they are adapted to seal with lead by the producer or to put the verification mark
11. Fixing holes - with the metallic upper hanger (3), they define the fixing points of the watt-hour meter in the power box (cabinet) or the niche for watt-hour meters
12. Terminal box - enables the connection of measuring circuits
13. Interface link - to connect interface wires

5. INSTALLATION

5.1 External dimensions and fixing way

Watt-hour meter overall dimensions are presented on the fig. 2.

The LS1.1 watt-hour meter is fixed on the wall.

Housing dimensions: 206 x 120 x 65 mm. The box has screw terminals with 6.5 mm internal diameter to connect to the power network, and auxiliary circuits with a wire up to 1.5 mm² cross-section.

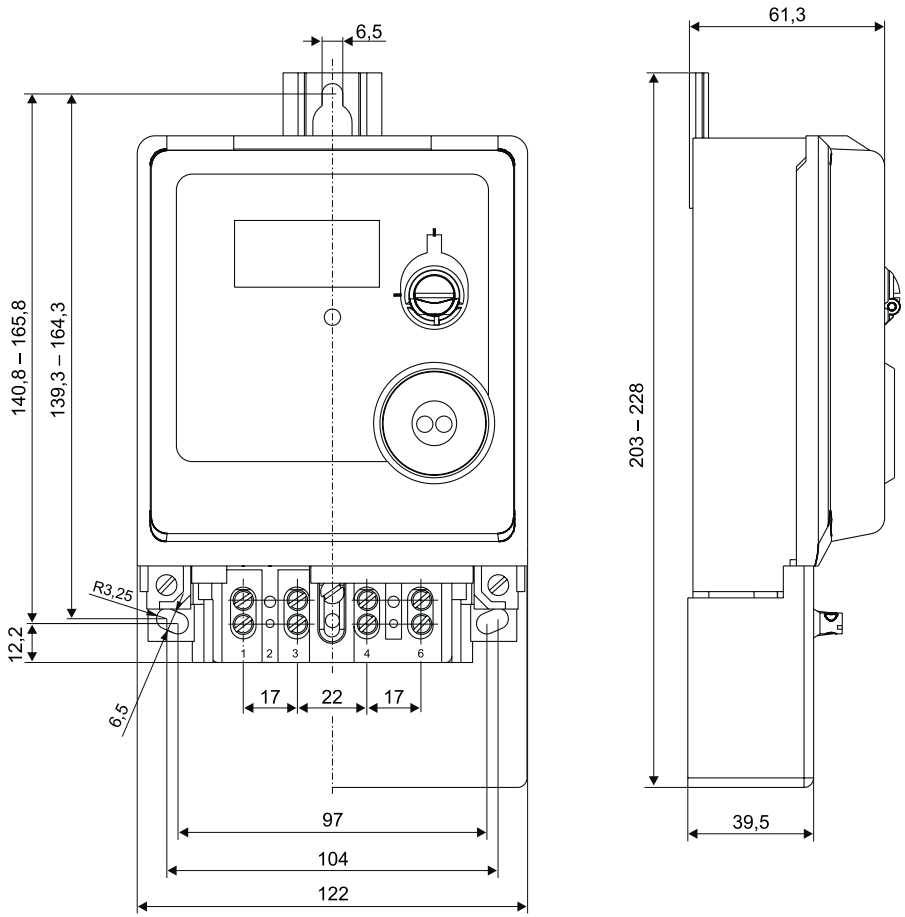
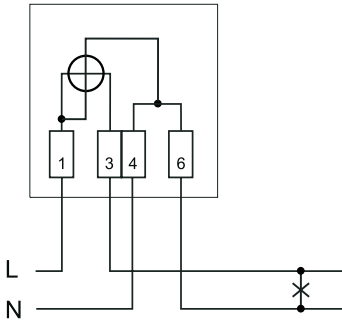
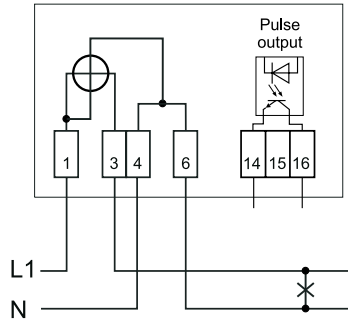

Fig. 2 Watt-hour meter overall dimensions

5.2 Connection diagrams



Single-tariff watt-hour meter for direct connection



Watt-hour meter with pulse output

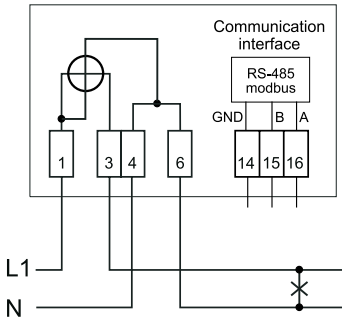

Watt-hour meter with an RS-485 communication interface and Modbus protocol

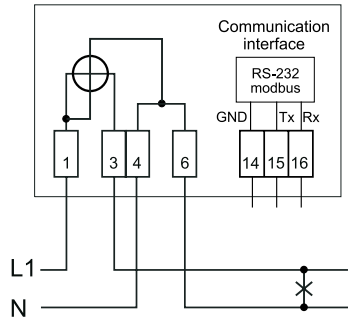

Watt-hour meter with an RS-232 communication interface and Modbus protocol

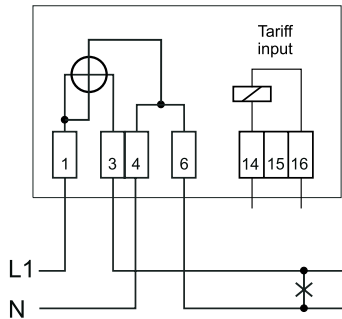

Two-tariff watt-hour meter with an external clock

Fig.3 External connection diagrams of the watt-hour meter

6. DISPLAYED INFORMATION

It is possible to readout following information on the LCD display:

- Energy in the current zone,
- ↓ Current time (in the hour:minute format),
- ↓ Current date (in the year.month.day format),
- ↓ Energy in zone T1,
- ↓ Energy in zone T2 (if occurs in the set tariff group),
- ↓ Energy in zone T3 (if occurs in the set tariff group),
- ↓ Energy in zone T4 (if occurs in the set tariff group),
- ↓ Total energy,
- ↓ Closing time of the accounting period (in the hour:minute format),
- ↓ Closing date of the accounting period (in the year.month.day format),
- ↓ Energy in zone T1 at the end of the previous accounting period,
- ↓ Energy in zone T2 at the end of the previous accounting period (if occurs in the set tariff group),
- ↓ Energy in zone T3 at the end of the previous accounting period (if occurs in the set tariff group),
- ↓ Energy in zone T4 at the end of the previous accounting period (if occurs in the set tariff group),
- ↓ Total energy at the end of the previous accounting period,
- ↓ Symbol of the set tariff group.

The start of information review, i.e. the transition from the energy display mode in the current zone, follows after pressing the button in the SCROLL position.

Successive information are sequentially accessible. After 30 seconds since the last button pressure, the watt-hour meter returns to the normal working mode. Depending on the option and watt-hour meter configuration, the number of accessible information in the review mode can be smaller

6.1 VIEW OF THE LCD DISPLAY

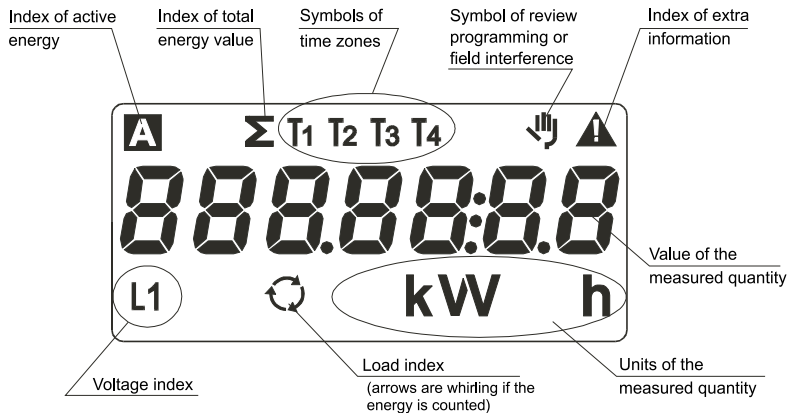

Fig. 4 LCD display

6.2 Displayed energy

In the LS1.1 watt-hour meter, the energy is displayed in kWh, with one decimal place. The counter register has 7 digits.

6.3 LED pulse output

The red lighting LED diode is the index of the energy flow.

The frequency of light flashes is proportional to the current energy flow.

6.4. Signalling of the phase voltage presence

The symbol consists of the letter 'L' positioned above the number '1'.

Fig. 5 Index of the phase voltage presence

The L1 index signals the presence of the phase voltage. In case when its value exceeds $0.9 U_n$

6.5 Signalling of the active time zone (tariffs)

The symbol features a large Greek letter sigma (Σ) followed by four distinct tariff symbols labeled T1, T2, T3, and T4.

Fig. 6 Tariff indexes

The active tariff zone is indicated by one of the symbols, e.g. for the first tariff the T1 symbol is displayed. For the total energy, all accessible tariff symbols together with the Σ sum mark are displayed.

6.6 Signalling of energy accounting



Fig. 7 Index of energy accounting

For signalling the energy accounting, an index composed of 3 arrows is accessible. If the energy is accounted, two arrows are shifting, giving the effect of the index turning round. If the watt-hour meter does not account the energy, all the 3 arrows are visible (they do not turn round). The index turning round speed is constant and does not depend on the measured energy.

6.7 Signalling of review and parameter programming or interference by a magnetic field.



Fig. 8 Index of parameter review programming or field interference

When the user reviews parameters in the SCROLL mode or enters in the SET programming mode, the symbol presented on the fig.8 is visible on the display.

The flickering symbol signals a strong magnetic field interference. If the watt-hour meter is under the influence of this field, then the index is lighting in a permanent way. If the magnetic field duration was longer than 30 seconds and the watt-hour meter is not under its influence, the index flickers till the time of erasing register of interference by the magnetic field through the optical link.

6.8 Signalling of housing opening (interference inside the watt-hour meter)

The lift of the frontal cover (interference inside the watt-hour meter) is signalled on the display by the flickering inscription „OPEN” alternatively with the current readout. In the same time, the date and the interference duration are recorded in the watt-hour meter memory.



Fig. 9 Screen signalling the housing opening

6.9 Signalling of additional information



Fig. 10 Index of additional information

The visible signal above on the display signals that the write through the optical link is allowed. However, the flickering symbol signals the incorrect work of the watt-hour meter.

7 CHANGE OF WATT-HOUR METER CONFIGURATION

The change of watt-hour meter configuration is possible in the programming mode (SET). The watt-hour meter is switched in the SET mode by means of the button.

7.1 Button

The watt-hour meter has one button. By means of this button set on the scroll position in the normal watt-hour meter operation, it is possible to review parameters described in the point 6.

In this position, the button can be leaden sealed. To transit to the SET position, one must remove the seal if exists and turn the button of 90° to the right. The table 1 presents the button functions.



Fig. 11 Available button positions

Button	Working mode	Function
SCROLL	REVIEW	Review of parameters
SCROLL	PROGRAMMING	Selection and change of programmable parameter values
SCROLL (> 2 sec.)	PROGRAMMING	Automatic incrementation of the parameter value
SET (> 2 sec.)	REVIEW	Entry into the parameter configuration mode
SET	PROGRAMMING	Selection of the parameter
SET (> 2 sec.)	PROGRAMMING	Acceptation of the parameter group change

The watt-hour meter transits from the parameter review mode, or from the configuration mode to the normal operation mode after 30 sec. from the last button use.

7.2. Service algorithm

The scheme of the main menu of the watt-hour meter configuration is presented on the fig. 10a. After pressing and hold down the button during at least 2 sec., in the SET position, it is possible to program parameters. The transition between parameters is made by means of the button on the SET position. The table 2 comprises the parameter description. The return to the normal operation follows after reviewing of all visible groups of parameters or automatically, after the laps of 30 sec. since the last button pressing.

Caution: same parameters or parameter settings can be invisible (inaccessible) depending on the watt-hour meter version and its current configuration.

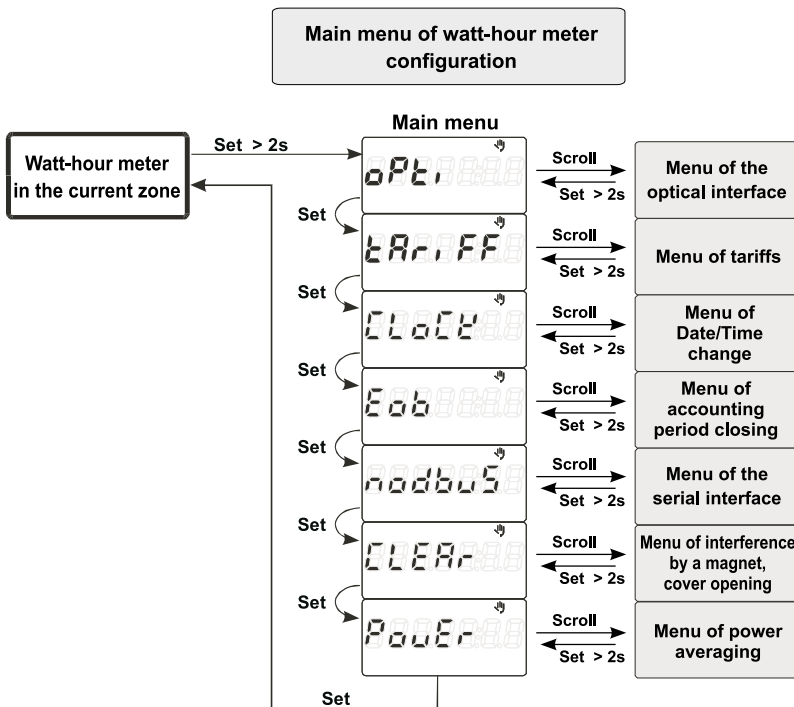

Fig. 12a Watt-hour work algorithm - Main menu

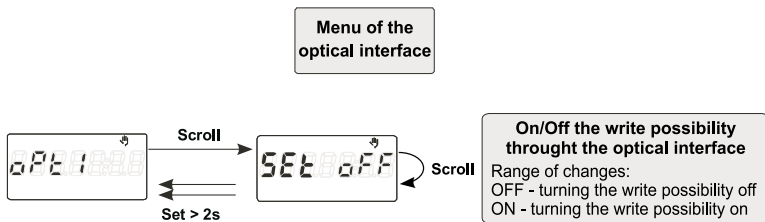

Fig. 12b Algorithm of the watt-hour meter work - menu of the optical interface.

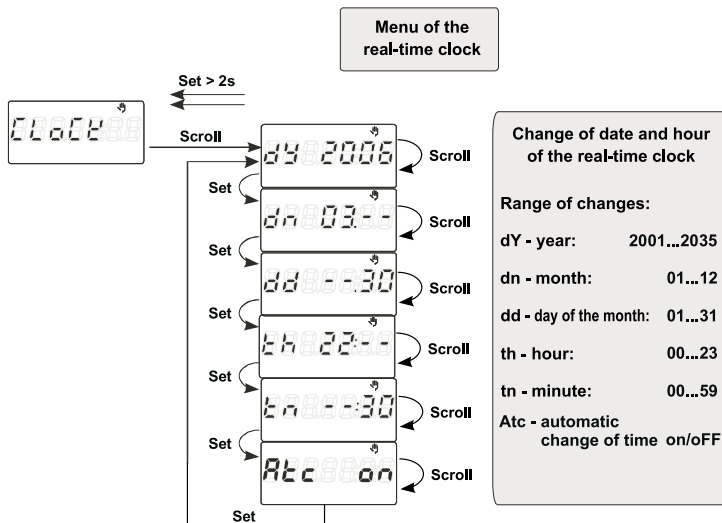

Fig. 12c Algorithm of the watt-hour meter work - menu of the real-time clock

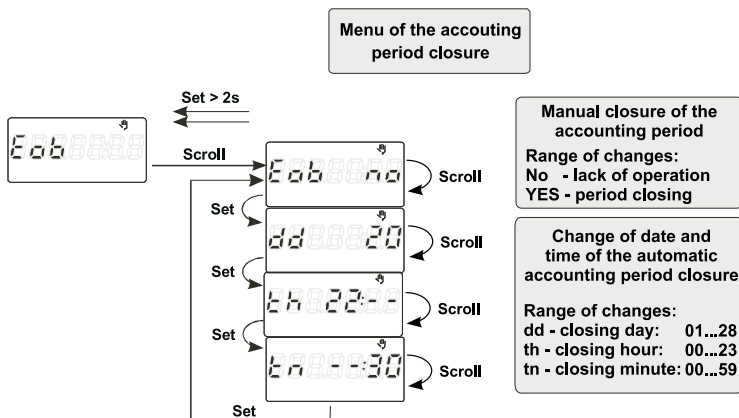

Fig. 12d Algorithm of the watt-hour meter work - menu of the accounting period closure

Menu of tariffs

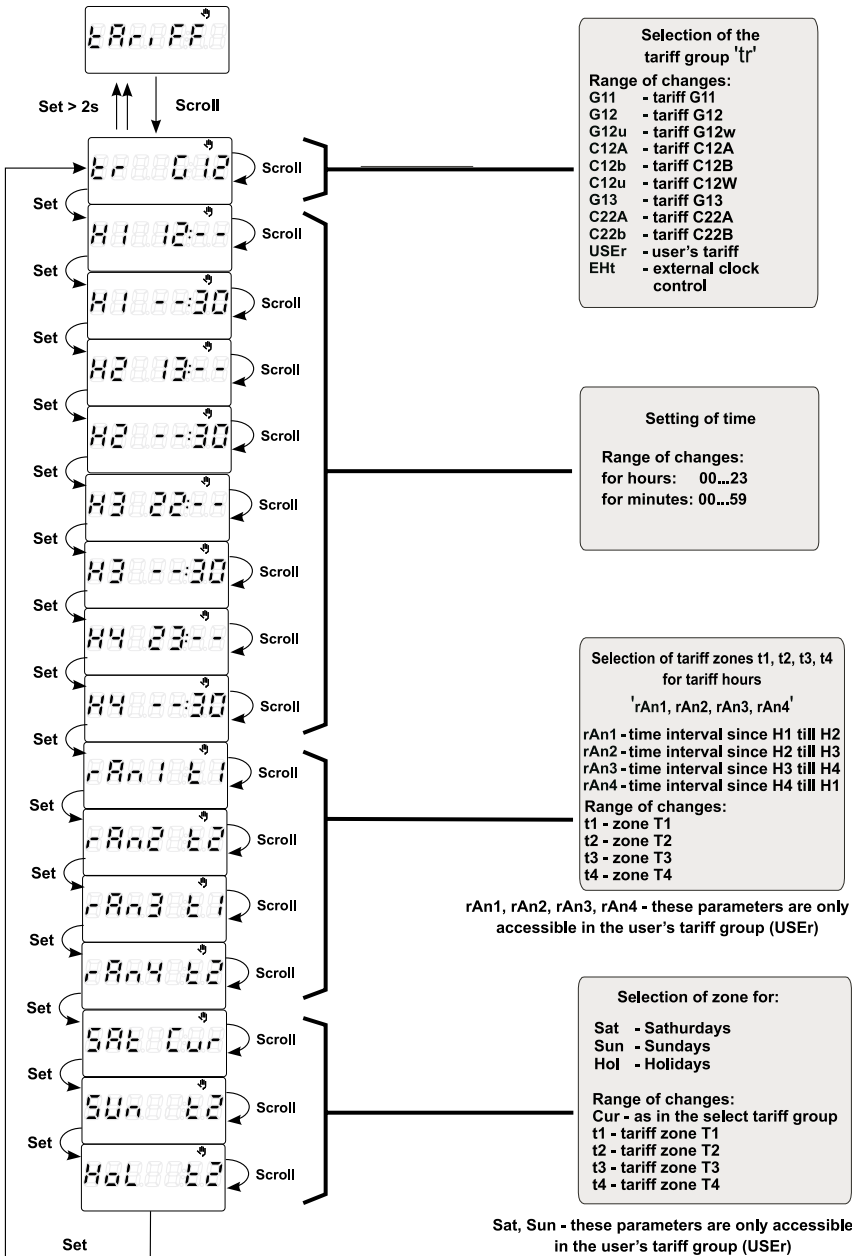

Fig. 12e Algorithm of the watt-hour meter work - menu of tariffs

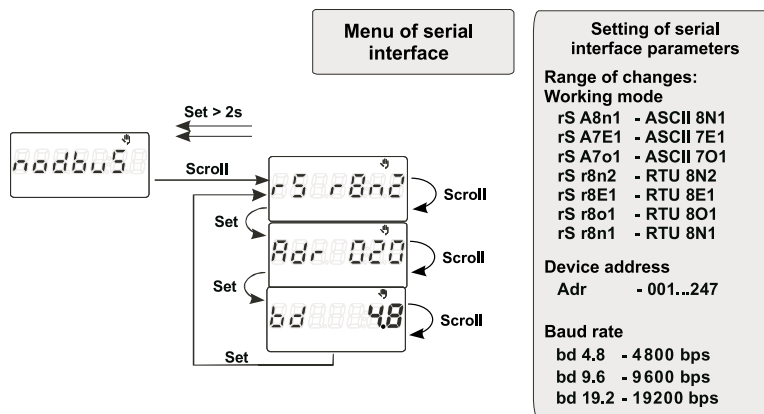

Fig. 12f Algorithm of the watt-hour meter work - menu of serial interface

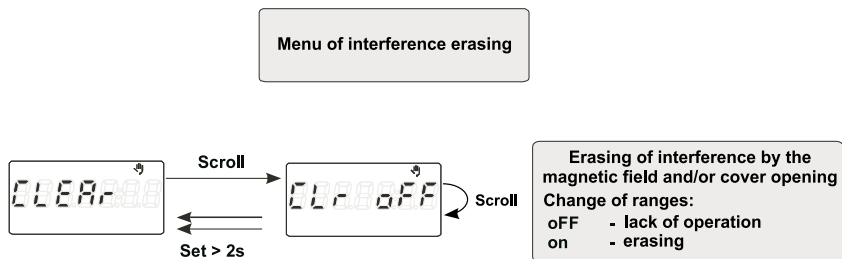

Fig. 12g Algorithm of the watt-hour meter work - menu of interference by a magnet and cover opening

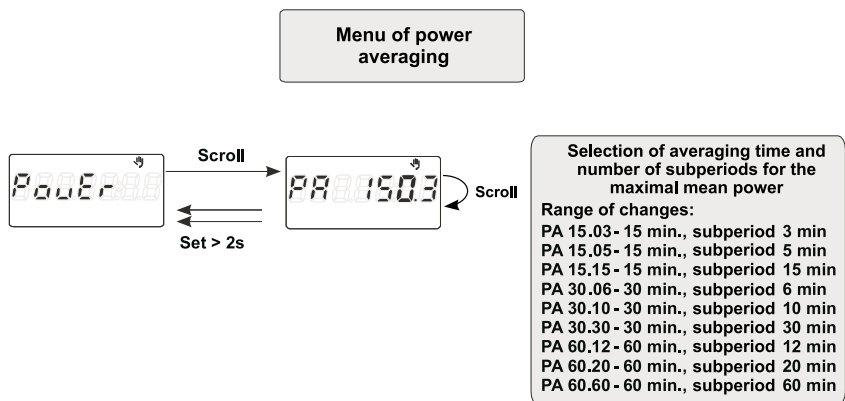

Fig. 12h Algorithm of watt-hour meter work - menu of power averaging

List of configuration parameters

Table 2

Main menu	Parameter symbol	Parameter description	Range of parametr changes
oPti	SEt	Possibility of write through the optical interface	oFF: disabled oN: enabled
tRr, FF	t r	Selection on the tariff	t 1: tariff group G11 t 2: tariff group G12 t 2w: tariff group C12w t 2a: tariff group C12a t 2b: tariff group C12b t 2w: tariff group C12w t 3: tariff group G13 t 2a: tariff group C22a t 2b: tariff group C22b USEr: User's tariff
	H 1	T1 time for tariff groups G12, G12w, C12b, C12w, USEr	00:00...07:00 or optionally for USEr
	H 2	T2 time for tariff groups G12, G12w, C12b, C12w, USEr	13:00...4:00 or optionally for USEr
	H 3	T3 time for tariff groups G12, G12w, C12b, C12w, USEr	15:00...6:00 or optionally for USEr
	H 4	T4 time for tariff groups G12, G12w, C12b, C12w, USEr	22:00...23:00 or optionally for USEr
	rAn 1	Selection of tariff for the time interval since H1 till H2. Parameter accessible only in the USEr tariff group.	t 1: T1 zone t 2: T2 zone t 3: T3 zone t 4: T4 zone
	rAn 2	Selection of tariff for the time interval since H2 till H3. Parameter accessible only in the USEr tariff group.	t 1: T1 zone t 2: T2 zone t 3: T3 zone t 4: T4 zone
	rAn 3	Selection of tariff for the time interval since H3 till H4. Parameter accessible only in the USEr tariff group.	t 1: T1 zone t 2: T2 zone t 3: T3 zone t 4: T4 zone
	rAn 4	Selection of tariff for the time interval since H4 till H1. Parameter accessible only in the USEr tariff group.	t 1: T1 zone t 2: T2 zone t 3: T3 zone t 4: T4 zone
	SRt	Selection of tariff zone for Saturdays. Parameter accessible only for the USEr tariff group. The selection of „Cur” parameter, causes that the watt-hour meter counts the energy according to settings of „rAn1... 4” parameters.	Cur: as in the selected tariff group t 1: T1 zone t 2: T2 zone t 3: T3 zone t 4: T4 zone
	SuN	Selection of tariff zone for Sundays. Parameter accessible only for the USEr tariff group. The selection of „Cur” parameter, causes that the watt-hour meter counts the energy according to settings of „rAn1... 4” parameters.	Cur: as in the selected tariff group t 1: T1 zone t 2: T2 zone t 3: T3 zone t 4: T4 zone
	HoL	Selection of tariff zone for Holidays. The selection of „Cur” parameter, causes that the watt-hour meter counts the energy in the zone resulting from the set tariff.	Cur: as in the selected tariff group t 1: T1 zone t 2: T2 zone t 3: T3 zone t 4: T4 zone

Main menu	Parameter symbol	Parameter description	Range of parametr changes
<i>clock</i>	<i>dy</i>	Current year	2001...2035
	<i>dn</i>	Current month	01...12
	<i>dd</i>	Current day	01...31
	<i>th</i>	Current hour	00...23
	<i>tn</i>	Current minute	00...59
	<i>Rtc</i>	Automatic change of the winter/summer time	OFF: turned off ON: turned on
<i>εob</i>	<i>εob</i>	Instant execution of the accounting period closure	no: no YES: yes
	<i>dd</i>	Day of automatic closure of the accounting period	01...28
	<i>th</i>	Hour of automatic closure of the accounting period	00...23
	<i>tn</i>	Minute of automatic closure of the accounting period	00...59
<i>modbus</i>	<i>rs</i>	Working mode	R8n : ASCII 8N1 R7E : ASCII 7E1 R7o : ASCII 7O1 r8n2: RTU 8N2 r8E : RTU 8E1 r8o : RTU 8O1 r8n : RTU 8N1
	<i>Rdr</i>	Address	1...247
	<i>bd</i>	Baud rate	4.8: 4800 bit/sec 9.6: 9600 bit/sec 19.2: 19200 bit/sec
<i>CLER</i>	<i>CLr</i>	Cancelation of the magnet interference and/or the cover opening	no: no YES: yes
<i>Power</i>	<i>PR</i>	Mode of power averaging	15.03: 15 min, subrange 3 min 15.05: 15 min, subrange 5 min 15.15: 15 min, subrange 15 min 30.05: 30 min, subrange 6 min 30.10: 30 min, subrange 10 min 30.30: 60 min, subrange 30 min 60.12: 60 min, subrange 12 min 60.20: 60 min, subrange 20 min 60.60: 60 min, subrange 60 min

8 ENERGY MEASUREMENT

8.1 Recording of energy in tariffs

In any time, the watt-hour meter accounts the energy in one of the tariffs. When the register reaches its maximal value 999 999.9 kWh, it is automatically reset and the account begins from zero.

8.2 Recording of total energy

The recording of the total energy consists in storing the total energy consumption in one register, independently of the tariff. When the register reaches its maximal value 999 999.9 kWh, it is automatically reset and the account begins from zero.

9 POWER REGISTERS

9.1 Averaged maximal power

The measurement of maximal power can be performed in 15, 30 or 60 minutes' periods. The locking mode or the shift mode is accessible to calculate the power.

For the shift mode, one can choose 5 or 3 subperiods falling on the integration period.

For 15 minutes, there will be 3 or 5 minutes' segments, for 30 minutes, 6 or 10 minutes' segments and for 60 minutes, 12 or 20 minutes' segments. The selected number of subperiods composes the period of power integration.

After the first complete shift period including all subperiods, the next subperiod will be accounted and the first is not be taken in consideration.

The watt-hour meter stores in its memory the maximal power for the current and the previous accounting period, and the time and date of its occurrence.

9.2 Cumulated power

The cumulated power is the power register increased by the averaged value of the maximal power at the end of the accounting period.

10 END OF THE ACCOUNTING PERIOD

At the moment of the accounting period closure, values of energy from all time zones and the total energy will be memorized and at the same time, values of the accounted energy do not undergo to changes.

The automatic closure can follow automatically, on the defined day of the month and in the given time. The configuration consists on writing the minute, hour and day of the accounting period closure. The closure of the accounting period, the date and time of this operation is written.

When there is a lack of closure possibility, e.g. because of a lack of supply, the closure process will be carried out after the supply voltage recovery.

After each closure of the accounting period, it is increased by one closure counter.

Note: It is recommended to close the accounting period during the watt-hour meter installation, so as to memorize initial values of energy already counted.

If the closure has been carried out in the day in which the automatic closure should occur, then the automatic closure will be cancelled on this day.

11 AVAILABLE TARIFF GROUPS

11.1 Tariff group G11

The energy is counted during the whole time in the T1 zone.

11.2. Tariff group G12

Table 3

Zone number	24 hours' zone	Period of time	
		(1 January - 31 December)	
1.	Daily zone (T1)	$H_1 - H_2$ $H_3 - H_4$	
2.	Night-time zone (T2)	$H_4 - H_1$ $H_2 - H_3$	

Notations:

$$H_1: 6^{00} + 7^{00}$$

$$H_2: 13^{00} + 14^{00}$$

$$H_3: 15^{00} + 16^{00}$$

$$H_4: 22^{00} + 23^{00}$$

Holidays are included to the zone depended on the setting of Hol parameter in tAriFF.

11.3. Tariff group G12w

Table 4

Zone number	24 hours' zone	Period of time	
		(1 January - 31 December)	
1.	Daily zone (T1)	$H_1 - H_2$ $H_3 - H_4$	
2.	Night-time zone (T2)	$H_4 - H_1$ $H_2 - H_3$	

Notations:

$$H_1: 6^{00} + 7^{00}$$

$$H_2: 13^{00} + 14^{00}$$

$$H_3: 15^{00} + 16^{00}$$

$$H_4: 22^{00} + 23^{00}$$

Holidays are included in the zone depended on the setting of Hol parameter in tAriFF

Saturdays and Sundays are included In the 24 hours' zone to the second zone - night-time zone

11.4. Tariff group C13

Table 5

Zone number	24 hours' zone	Period of time	
		Summer	Winter
		(1 April - 30 September)	(1 October - 31 March)
1.	Ante-meridian peak (T1)	$7^{00} - 13^{00}$	$7^{00} - 13^{00}$
2.	Post-meridian peak (T2)	$19^{00} - 22^{00}$	$16^{00} - 21^{00}$
3.	Remaining hours of the 24 hours' zone (T3)	$13^{00} - 19^{00}$ $22^{00} - 7^{00}$	$13^{00} - 16^{00}$ $21^{00} - 7^{00}$

Legal day-offs, Saturdays and Sundays are included in the 24 hours' zone to the third zone, as remaining hours of the 24 hours' zone.

11.5. Tariff group C12a

Table 6

Zone number	24 hours' zone	Period of time	
		Summer (1 April - 30 September)	Winter (1 October - 31 March)
1.	Peak zone (T1)	8 ⁰⁰ - 11 ⁰⁰ 20 ⁰⁰ - 21 ⁰⁰	8 ⁰⁰ - 11 ⁰⁰ 17 ⁰⁰ - 21 ⁰⁰
2.	Extrapeak zone (T2)	11 ⁰⁰ - 20 ⁰⁰ 21 ⁰⁰ - 8 ⁰⁰	11 ⁰⁰ - 17 ⁰⁰ 21 ⁰⁰ - 8 ⁰⁰

Holidays are included to the zone depended on the setting of Hol parameter in tAriFF

11.6. Tariff group C12b

Table 7

Zone number	24 hours' zone	Period of time
		(1 January - 31 December)
1.	Daily zone (T1)	H ₁ - H ₂ H ₃ - H ₄
2.	Night-time zone (T2)	H ₄ - H ₁ H ₂ - H ₃

Notations:

$$H_1: 6^{00} \div 7^{00}$$

$$H_2: 13^{00} \div 14^{00}$$

$$H_3: 15^{00} \div 16^{00}$$

$$H_4: 22^{00} \div 23^{00}$$

Holidays are included to the zone depended on the setting of Hol parameter in tAriFF

11.7. Tariff group C12w

Table 8

Zone number	24 hours' zone	Period of time
		(1 January - 31 December)
1.	Daily zone (T1)	H ₁ - H ₂ H ₃ - H ₄
2.	Night-time zone (T2)	H ₄ - H ₁ H ₂ - H ₃

Notations:

$$H_1: 6^{00} \div 7^{00}$$

$$H_2: 13^{00} \div 14^{00}$$

$$H_3: 15^{00} \div 16^{00}$$

$$H_4: 22^{00} \div 23^{00}$$

Saturdays and Sundays are included In the 24 hours' zone, to the second zone - night-time

Holidays are included to the zone depended on the setting of Hol parameter in tAriFF

11.8. Tariff group C22a

Table 9

Zone number	24 hours' zone	Period of time			
		I, II, XI, XII	III, X	IV, IX	V, VI, VII, VIII
1.	Peak zone (T1)	8 ⁰⁰ - 11 ⁰⁰ 16 ⁰⁰ - 21 ⁰⁰	8 ⁰⁰ - 11 ⁰⁰ 18 ⁰⁰ - 21 ⁰⁰	8 ⁰⁰ - 11 ⁰⁰ 19 ⁰⁰ - 21 ⁰⁰	8 ⁰⁰ - 11 ⁰⁰ 20 ⁰⁰ - 21 ⁰⁰
2.	Extrapeak zone (T2)	21 ⁰⁰ - 8 ⁰⁰ 11 ⁰⁰ - 16 ⁰⁰	21 ⁰⁰ - 8 ⁰⁰ 11 ⁰⁰ - 18 ⁰⁰	21 ⁰⁰ - 8 ⁰⁰ 11 ⁰⁰ - 19 ⁰⁰	21 ⁰⁰ - 8 ⁰⁰ 11 ⁰⁰ - 20 ⁰⁰

Holidays are included to the zone depended on the setting of Hol parameter in tAriFF

11.9. Tariff group C22b

Table 10

Zone number	24 hours' zone	Period of time
		(1 January - 31 December)
1.	Peak zone (T1)	6 ⁰⁰ - 21 ⁰⁰
2.	Extrapeak zone (T2)	21 ⁰⁰ - 6 ⁰⁰

Holidays are included to the zone depended on the setting of Hol parameter in tAriFF

11.10. Liste of holidays

Following days are implemented in the watt-hour meter, as permanent holidays:

statutorily free of work:

1st January	- New Year,
1st May	- International Holiday of the 1st of May,
3rd May	- National Holiday of 3rd May,
15th August	- Assumption,
1st November	- All Saints Day,
11st November	- Independence Day,
25th December	- First Day of Christmas,
26th December	- Second Day of Christmas.

Movable feasts: The first day of Easter, Corpus Christi.

12 OPTICAL INTERFACE

Parameter set of the optical link of the LS1.1 watt-hour meter:

- conformity with the standard	EN62056-21
- manufacturer identifier	LML
- baud rate identifier	4
- watt-hour meter identifier	LS11-LUMEL
- transmission protocol	mode C of transmission
- transmission initialization	300 baud
- available baud rates	300, 600, 1200, 2400, 4800 baud
- character format acc. to ISO 1177	7E1
- write interlock	button secured by a leaden seal

The optical interface in the watt-hour meter enables the realization of following functions:

- data readout from the watt-hour meter,
- write of selected parameters to the watt-hour meter,
- closure of the accounting period.

The write of parameters and closure of the current accounting period are possible after breaking the leaden seal and setting the button on the SET position.

To unlock or lock the write, one must:

- press the SET button in a time longer than 2 sec,
- pressing the SET button, transit to the „oPŁ.“ menu,
- by means of the SCROLL button unlock the „SEŁ oŁ“ write or lock the „SEŁ oFF“ write,
- pressing the SET button in a time longer than 2 sec, accept the change,
- pressing the SET button, exit from the SETUP procedure.

The locking of the write follows automatically after a 5 minutes' lack of communication through the optical link.

12.1 Watt-hour meter registers in the readout mode

The list of registers with identifiers and the example of contents in case of data readout is presented in the tables below.

Note: Depending on the option and watt-hour meter configurations, the number of available registers for readout can be smaller.

Table 11

Identifier (ASCII characters)	Format of ASCII characters (example of contents)	Parameter
28	12:34:56	Current time
29	25-11-02	Current date (dd:mm:yy)
0.0	AbcDeFgHiJ	User's identifier
0.0.1	02110001	Factory number
0.8.1	000123.4*kWh	Energy in zone 1
0.8.2	000423.4*kWh	Energy in zone 2
0.8.3	000623.4*kWh	Energy in zone 3
0.8.4	000723.4*kWh	Energy in zone 4
0.8.0	001323.4*kWh	Total energy from all zones
0.6.0	10:23 20-11-02; 99.2*kW	Time and date of the maximal 15', 30' or 60' power occurrence and its value.
70.	10:23 20-11-02	Time and date of the account period closure.
0.8.1*00	000123.4*kWh	Energy in zone 1 at the end of the previous account period.
0.8.2*00	000423.4*kWh	Energy in zone 2 at the end of the previous account period.
0.8.3*00	000623.4*kWh	Energy in zone 3 at the end of the previous account period.
0.8.4*00	000723.4*kWh	Energy in zone 4 at the end of the previous account period
0.8.0*00	001323.4*kWh	Total energy at the end of the previous account period.
0.6.0*00	10:23 19-11-02; 90.2*kW	Time and date of the max. 15', 30' or 60' power occurrence in the previous account period and its value.
0.6	6344.7*kW	Cumulated power (max. „65535“)
0.1.	22352	Counter of account period closures (max. „65535“)

Table 11 (continuation)

Identifier (ASCII charac- ters)	Format of ASCII charac- ters (example of contents)	Parameter
54.	010301	Watt-hour meter status: 1 st character - Signalling of voltage in the phase ('0' - $U < 0.9 U_n$; '1' - $U \geq 0.9 U_n$) 2 nd character - Always '0' 3 rd character - Always '0' 4 th character - Current time zone: '1' - 1 st zone T1 '2' - 2 nd zone T2 '3' - 3 nd zone T3 '4' - 4 th zone T4 5 th character - Signalling of cover opening ('0' or '1') 6 th character - Signalling of magnetic field interference ('0' or '1')
FF	01101000 00011000	Register of watt-hour meter errors (see table 12) ('0' or '1')
0.43	7	Time of power averaging and number of subperiods: '0' - 15 min, 3 min'subperiod '1' - 15 min, 5 min'subperiod '2' - 15 min, 15 min'subperiod '3' - 30 min, 6 min'subperiod '4' - 30 min, 10 min'subperiod '5' - 30 min, 30 min'subperiod '6' - 60 min, 12 min'subperiod '7' - 60 min, 20 min'subperiod '8' - 60 min, 60 min'subperiod
50.	17;13:55	Day and time in which the account period is closed. (day '00' - automatic closure is off; day '01'...'28'; hour '00'...'23' : minute '00'...'59')
51.	05	Tariff groups: '00' - G11 '01' - G12 '02' - G12w '03' - C12a '04' - C12b '05' - C12w '06' - G13 '07' - C22a '08' - C22b '09' - USEr (user's tariff) '10' - controlled by the external clock
51.1	07:20; 10:12; 22:30; 23:30	Variable hours for tariffs: G12, G12w, C12b, C12w, USEr

Table 11 (continuation)

51.2	1010114	<p>Time zones for Saturdays, Sundays and holydays (only for USEr tariff)</p> <p>1st character - zone for hour interval since H1 till H2 2 nd character - zone for the hour interval since H2 till H3 3 rd character - zone for the hour interval since H3 till H4 4 th character - zone for the hour interval since H4 till H1</p> <p>Meaning of 1...4 charac- '0' - T1 zone '1' - T2 zone '2' - T3 zone '3' - T4 zone</p> <p>5 th character - Zone for Saturdays (only for USEr tariff) 6 th character - Zone for Sundays (only for USEr tariff) 7 th character - Zone for holidays</p> <p>Meaning of 5...7 characters: '0' - as in the selected tariff group '1' - T1 zone '2' - T2 zone '3' - T3 zone '4' - T4 zone</p> <p>In case when choosing '0', time zones are defined acc. to the chosen tariff group (see the description of tariff zones in Table 2.</p>
52.	22112	<p>Configuration of the serial link (mode, address, baud rate):</p> <p>1 st character - mode '1' - ASCII 8N1 '2' - ASCII 7E1 '3' - ASCII 7O1 '4' - RTU 8N2 '5' - RTU 8E1 '6' - RTU 8O1 '7' - RTU 8N1</p> <p>2, 3, 4 th character - address („001”...”247”) 5 th character - baud rate '0' - 4800 baud '1' - 9600 baud '2' - 19200 baud</p>
53.	6.4	No of the program version
55.	1	<p>Automatic change of winter time/summer time '0' - off '1' - on</p>
76.1	10:12 25-11-05;	Hour and date of the beginning of interference by a strong magnetic field
76.2	0000000327	Duration of interference by a strong magnetic field [sec]
77.	0	<p>Index of cover opening (interference into the watt-hour meter) '0' - There was no opening '1' - There was or/there is an opening</p>
78	00003	Number of register erasing of interference by a strong magnetic field and/or housing opening.

Character number	Description
0	Detection of erroneous contents - energy in zone T1
1	Detection of erroneous contents - energy in zone T2
2	Detection of erroneous contents - energy in zone T3
3	Detection of erroneous contents - energy in zone T4
4	Detection of erroneous contents - total energy
5	Detection of erroneous contents - energy in zone T1 in the previous account period
6	Detection of erroneous contents - energy in zone T1 in the previous account period
7	Detection of erroneous contents - energy in zone T2 in the previous account period
8	Detection of erroneous contents - energy in zone T3 in the previous account period
9	Detection of erroneous contents - total energy in the previous account period
10-14	Not used
15	Incorrect value of the error register.

12.2 Watt-hour meter registers in the programming and read-out mode

List of watt-hour meter registers with identifiers and example of contents in case of readout and/or data write in the programming mode.

Table 13

Identifier (ASCII characters)	Format of ASCII characters (example of contents)	Parameter	Functions
T	12:34:56 25-11-02	Current time and date	R/W
A	1	Automatic time change winter/summer acc. to fig.10c	R/W
I	AbcDeFgHiJ	User's identifier	R/W
N	02110001	Factory number	R
D	7	Power averaging time and number of subperiods: (like in table 11)	R/W
E	17;13:55	Day and time in which the account period is closed. (day „00“ ... „28“)	R/W
G	05	Kind of tariff group (like in table 11)	R/W
H	07:20; 10:12 22:30; 23:30	Variable hours for tariffs: G12, G12w, C12b, C12w, USER	R/W
C	22112	Configuration of the serial link (mode, address, baud rate) (like in table 11)	R/W
R	1	Register erasing of interference by a strong magnetic field and cover opening.	R/W

Table 13 (continuation)

Z	1010111	<p>Selection of the time zone for tariff hours, Saturdays, Sundays and holidays (only for USEr tariff).</p> <p>1 st character – selection of zone for the hour interval since H1 till H2 2 nd character – selection of zone for the hour interval since H2 till H3 3 rd character – selection of zone for the hour interval since H3 till H4 4 th character – selection of zone for the hour interval since H4 till H1</p>	R/W
		<p>Meaning of 1...4 characters: '0' - T1 zone '1' - T2 zone '2' - T3 zone '3' - T4 zone</p>	
		<p>5 th character - selection of zone for Saturdays (only for USEr tariff) 6 th character - selection of zone for Sundays (only for USEr tariff) 7 th character - selection of zone for holidays</p>	
		<p>Meaning of 5...7 characters: '0' - as for the selected tariff group '1' - T1 zone '2' - T2 zone '3' - T3 zone '4' - T4 zone</p> <p>In case when '0' is chosen, time zones are defined acc. to the selected tariff group (see the description of the tariff zones in Table 2)</p>	

Notations: R - only for readout
R/W - readout and write

Note: In case of a watt-hour meter configuration, when the given parameter is not used, the caractere code '-' (minus) is returned.

13. RS-485 or RS-232 SERIAL INTERFACE WITH MODBUS PROTOCOL

13.1 Set of serial interface parameters:

- identifier 0xA0
- watt-hour meter address 1... 247
- baud rate 4800, 9600, 19200 bodów,
- working mode ASCII, RTU,
- information unit ASCII: 8N1, 7E1, 7O1;
RTU: 8N2, 8E1, 8O1, 8N1,
- maximal response time 600 ms.

Factory settings: address: 1, baud rate: 9600 baud, RTU mode: 8N2.

LS1.1. watt-hour meter realizes following protocol functions:

Table 14

Code	Meaning
03	Readout of n-registers
17	Identification of the slave device

13.2 Map of watt-hour meter registers

Data are placed in 16-bit registers. Process variables and watt-hour meter parameters are placed in the register address space in a way depending on the type of the variable value.

Bits in the 16-bit registers are numbered from the youngest to the oldest (b0-b15).

Table of watt-hour meter 16-bit registers

Table 15

Register number	Parameter	Range	Description
4000	word	0... 65535	Watt-hour meter status ← description in table 16.
4001	word	2001... 2035	Current year
4002	word	101... 1231	Current date in format: month * 100 + day
4003	word	0... 2359	Current time in format: hour * 100 + minute
4004	MS word	05010001...	Serial number
4005	LS word	35129999	
4006	word	0x00... 0xEE	User's identifier (1 and 2 character)
4007	word	0x00... 0xEE	User's identifier (3 and 4 character)
4008	word	0x00... 0xEE	User's identifier (5 and 6 character)
4009	word	0x00... 0xEE	User's identifier (7 and 8 character)
4010	word	0x00... 0xEE	User's identifier (9 and 10 character)
4011	MS word	0... 99999999	Active energy in zone T1 (kWhx100)
4012	LS word		
4013	MS word	0... 99999999	Active energy in zone T2 (kWhx100)
4014	LS word		
4015	MS word	0... 99999999	Active energy in zone T3 (kWhx100)
4016	LS word		
4017	MS word	0... 99999999	Active energy in zone T4 (kWhx100)
4018	LS word		
4019	MS word	0... 99999999	Total active energy
4020	LS word		
4021	MS word		Reserved
4022	LS word		
4023	MS word		Reserved
4024	LS word		
4025	MS word		Reserved
4026	LS word		
4027	MS word	0... 99999999	Active energy in zone T1 at the end of the previous accounting period (kWhx100)
4028	LS word		

Table of watt-hour meter 16-bit registers

Table 15 (continuation)

4029	MS word	0... 99999999	Active energy in zone T2 at the end of the previous accounting period (kWhx100)
4030	LS word		
4031	MS word	0... 99999999	Active energy in zone T3 at the end of the previous accounting period (kWhx100)
4032	LS word		
4033	MS word	0... 99999999	Active energy in zone T4 at the end of the previous accounting period (kWhx100)
4034	LS word		
4035	MS word	0... 99999999	Total active energy at the end of the previous accounting period (kWhx100)
4036	LS word		
4037	word	0... 65535	Counter of accounting period closures
4038	word	2001... 2035	Year of accounting energy closure
4039	word	101... 1231	Date of accounting period closure in format: month * 100 + day
4040	word	0... 2359	Time of accounting period closure in format: hour * 100 + minute
4041	word	0... 700	The highest value of averaged power (kWh x10)
4042	word	2001... 2035	Year of the highest value of averaged power occurrence
4043	word	101... 1231	Date of the highest value of averaged power occurrence in format: month * 100 + day
4044	word	0... 2359	Time of the highest value of averaged power occurrence in format: hour * 100 + minute
4045	word	0... 455	The highest value of averaged power in the previous accounting period.
4046	word	2001... 2035	The year of the highest value of averaged power occurrence in the previous accounting period
4047	word	101... 1231	The date of the highest value of averaged power in the previous accounting period in format: month * 100 + day
4048	word	0... 2359	The time of the highest value of averaged power in the previous accounting period in format: hour * 100 + minute
4049	word	0... 65535	Cumulated power (kW x 10)

Table of watt-hour meter 16-bit registers

Table 15 (continuation)

4050	word	0... 8	Way of power averaging 0 - 15 min, 3 min'subperiod 1 - 15 min, 5 min'subperiod 2 - 15 min, 15 min'subperiod 3 - 30 min, 6 min'subperiod 4 - 30 min, 10 min'subperiod 5 - 30 min, 30 min'subperiod 6 - 60 min, 12 min'subperiod 7 - 60 min, 20 min'subperiod 8 - 60 min, 60 min'subperiod
4051	word	0... 2359	Time of the automatic accounting period closure in format: hour * 100 + minute
4052	word	0... 28	Day of the automatic accounting period closure
4053	word	0... 32000	Constant of pulse output: (imp/kWh)
4054	word	0... 10	Tariff group: 0 - G11 1 - G12 2 - G12w 3 - C12a 4 - C12b 5 - C12w 6 - G13 7 - C22a 8 - C22b 9 - USEr (user's tariff) 10 - external clock control
4055	word	10... X	Number of the program version (x10)
4056	word	0... 65535	Register of watt-hour meter errors ← description in table 17.
4057	word	2001... 2035	Year of the first beginning of interference by a strong magnetic field
4058	word	101... 1231	Month and day of the first beginning of interference by a strong magnetic field
4059	word	0... 2359	Time of the first beginning of interference by a strong magnetic field
4060	MS word	0... (2 ³² -1)	Duration of interference by a strong magnetic field
4061	LS word		
4062	word	0... 1	Index of cover opening (interference in the watt-hour meter)
4063	word	0... 65535	Number of erasings of interference by a strong magnetic field and/or the index of cover opening

Bit	Description
0	Signalling of voltage in phase 0 - voltage under 0,9 Un 1 - voltage over 0,9 Un
1	Always 0
2	Always 0
3 - 5	Current time zone Bits: 5 4 3 0 0 1 - T1 zone 0 1 0 - T2 zone 0 1 1 - T3 zone 1 0 0 - T4 zone
6 - 7	Decimal places for power Bits: 7 6 0 0 - without decimal places 0 1 - 1 decimal place 1 0 - 2 decimal places
8 - 9	Decimal places for energy Bits: 9 8 0 0 - without decimal places 0 1 - 1 decimal place 1 0 - 2 decimal places
10 - 11	Prefix of the unit for energy and power Bits: 11 10 0 0 - lack 0 1 - k 1 0 - M
12	Interference by a strong magnetic field 0 - lack 1 - exist
13	Opening of the watt-hour meter cover 0 - cover closed 1 - cover open
14	Not used
15	Error 0 - no errors 0 - one must check the error register

Bit	Description
0	Detection of an erroneous contents - energy in zone T1
1	Detection of an erroneous contents - energy in zone T2
2	Detection of an erroneous contents - energy in zone T3
3	Detection of an erroneous contents - energy in zone T4
4	Detection of an erroneous contents - total energy
5	Detection of an erroneous contents - energy in zone T1 in the previous accounting period
6	Detection of an erroneous contents - energy in zone T2 in the previous accounting period
7	Detection of an erroneous contents - energy in zone T3 in the previous accounting period
8	Detection of an erroneous contents - energy in zone T4 in the previous accounting period
9	Detection of an erroneous contents - total energy in the previous accounting period
10 - 14	Not used
15	Incorrect value of the error register

14. INTERNAL CONTROL CLOCK (OPTION)

The LS1.1. watt-hour meter has an astronomical time clock supported by a battery. The current time is counted in the 24-hour' format.

This clock is used for the time zone switching. The clock has the function of the automatic change from the winter time into the summer time and inversely. The transition from the winter time into the summer time is carried out in the night from Saturday to Sunday, on the last Sunday of Mars the clock is being transposed from 2:00 to 3:00 o'clock. The transition from the summer time into the winter time is carried out in the night from Saturday to Sunday, on the last Sunday of October the clock is being transposed from 3:00 to 2:00 o'clock. If the user set the current time between 2:00 and 3:00, on the last Sunday of October, the clock assumes the summer time.

15. TECHNICAL DATA

Kind of network	2 - wire
Connection way of the watt-hour meter	direct
Reference voltage U_n	acc. to the version code
Basic current I_b	acc. to the version code
Maximal current I_{max}	acc. to the version code
Accuracy class	acc. to the version code

Working temperature range	- 35... 65°C
Storage ambient temperature	- 35... 80°C
Power consumption:	
- in the voltage circuit	≤ 8 VA/0.3 W
- in the voltage circuit for a watt-hour meter with RS-485, RS-232 interface or a radio module	≤ 7 VA/1.3 W
- in the current circuit	≤ 0.015 VA
Starting current	0,004 I _b
Detection level of the voltage presence	0,90 U _n
Pulse constant of the LED diode	3200 imp./kWh or another (to agree)
Readout field	special LCD display
Communication interfaces	acc. to the version code
Output of energy pulses	output of O.C. type, passive acc. to EN 62053-31
Pulse constant of O.C. output	3200 imp./kWh or another (to agree)
Tariff input	1 input (2 tariffs), switched voltage U _n
Available tariffs	G11, G12, G12w, G13, C12a, C12b, C12w, C22a, C22b, 1 tariff programmed by the user
Number of tariff zones	from 1 to 4
Resistance against external permanent magnetic field	640 kA/m
Resistance against surge voltages	4 kV
Reaction of the watt-hour meter to voltage decays	Storage of data and the watt-hour meter state after the decay in the FRAM non-volatile memory, storage durability: min. 15 years
Clock accuracy	± 2s/day
Protection degree ensured by the housing	IP 54
Battery life time	minimum 10 years
External dimensions (H × W × D)	203 × 122 × 65 mm
Weight	ca. 0,75 kg

16. ORDER CODES

Table 18

Electronic single-phase watt-hour meter - LS1.1	X	X	XX	X	X	X
Basic and maximal current:						
5 (40) A						1
5 (60) A						2
10 (40) A						4
10 (60) A						5
as per order ¹⁾						X
Input voltage:						
230 V						1
as per order ¹⁾						X
Communication interface:						
optical port						00
optical port + pulse output (open collector)						01
optical port + output of RS-485 type (Modbus)						02
optical port + output of RS-232 type (Modbus)						04
without optical port and interfaces ³⁾						05
optical port + radio module ¹⁾						20
as per order ¹⁾						XX
Accuracy class:						
accuracy clas 1						1
accuracy clas 2						2
Tariffs:						
single-tariff without internal clock						1
single or multi-tariff with internal clock						2
two-tariff with external clock ¹⁾²⁾						3
Acceptance tests:						
without legalization						8
with legalization						7
acc. to user's agreements ¹⁾						X

¹⁾ - Custom-made version, one must agree with the manufacturer

²⁾ - Concerns only the version LS1-1 X X 00 X X X (optical port)

³⁾ - Concerns only the 1-tariff version with internal clock of LS1.1 - X X XX X 1X

CODING EXAMPLE:

The code: **LS1.1 2 1 01 1 1 8** means:

- LS1.1** - Electronic single-phase watt-hour meter with LCD display
- 2** - Basic and maximal current: 5 (60) A
- 1** - Input voltage: 230 V
- 01** - Communication interface: optical port and output of O/C type
- 1** - Accuracy class: 1
- 1** - Single tariff version
- 8** - Delivered without a legalization certificate

17. MAINTENANCE AND WARRANTY

The LS1.1 watt-hour meter does not require any periodical maintenance. In case of some incorrect operations:

1. After the dispatch date and within the period stated in the warranty card

One should return the watt-hour meter to the Quality Inspection Dept.

If the instrument has been used in compliance with the instructions, we warrant to repair it free of charge.

The disassembling of the housing causes the cancellation of the granted warranty.

2. After the warranty period:

One should send the instrument to repair it in an authorized service workshop.

Spare parts are available for the period of five years from the date of purchase.

Our policy is one of continuous improvement and we reserve the right to make changes in design and specifications of any products as engineering advances or necessity requires and revise the above specifications without notice.

SALES PROGRAM

- DIGITAL and BARGRAPH PANEL METERS
- MEASURING TRANSDUCERS
- ANALOG PANEL METERS (DIN INSTRUMENTS)
- ANALOG and DIGITAL CLAMP-ON METERS
- INDUSTRIAL and HOUSEHOLD CONTROLLERS
- CHART AND PAPERLESS RECORDERS
- POWER CONTROL UNITS and INVERTERS
- LARGE SIZE NUMERIC and ALPHANUMERIC DISPLAYS
- AUTOMOTIVE DASHBOARD INDICATORS
- ACCESSORIES FOR MEASURING INSTRUMENTS
- MEASURING SYSTEMS (ENERGY, HEAT, CONTROL)
- CUSTOM-MADE PRODUCTS

WE ALSO OFFER OUR SERVICES IN THE PRODUCTION OF:

- ALUMINIUM ALLOY PRESSURE CASTINGS
- PRECISION ENGINEERING AND THERMOPLASTICS PARTS
- PRESSURE CASTING DIES AND OTHER TOOLS

QUALITY PROCEDURES

ACCORDING TO ISO 9001 AND ISO 14001 INTERNATIONAL REQUIREMENTS.

All our instruments have CE mark and respect RoHs Directives.

For more information, please write to or phone our Export Department

LS1.1-07A



Lubuskie Zakłady Aparatów Elektrycznych LUMEL S.A.

ul. Sulechowska 1, 65-022 Zielona Góra, Poland

Tel.: (48-68) 329 51 00 (exchange)

Fax: (48-68) 329 51 01

e-mail: lumel@lumel.com.pl

<http://www.lumel.com.pl>

Export Department:

Tel.: (48-68) 329 53 02 or 53 04

Fax: (48-68) 325 40 91

e-mail: export@lumel.com.pl