



6 YEARS GUARANTEE
APPROVED QUALITY

Vibranivo® 1000 / 5000

Vibration level limit switch

The universal unit for reliable level monitoring of granulated and powdered bulk goods – versatile, suitable especially for applications with high mechanical loading and measurement of bulk goods in liquids; certified for hazardous locations (gas and dust)







Vibranivo® 1000 / 5000



- Modular and simple design
- For applications with high mechanical loading
- Particularly suitable for interface measurement
- Absolutely maintenance free

Application: Vibranivo® probes can be used as full, demand or empty detectors in bulk good silos. They are especially suited for use in all solids which are conveyed or stored under extreme conditions as well as for interface measurement. The short fork design allows mounting in containers with very limited space. VN vibration forks are available with international certificates for applications in hazardous locations (gas and dust).

Types of Vibranivo demand, full and empty detectors:

Vibranivo® ..020	Vibranivo® ..030	Vibranivo® ..040	Vibranivo® ..050
Short extension length, vertical, horizontal and oblique installation	Design with pipe extension, vertical and oblique installation	Delivery without pipe extension (reduced shipping costs, flexible length), vertical and oblique installation	Model with cable extension, vertical installation up to 7 m measuring range
			

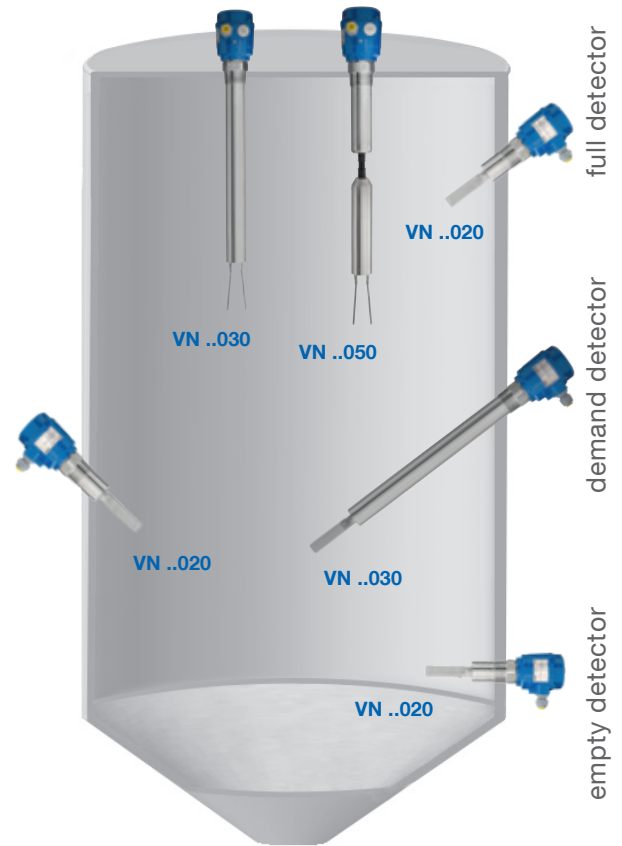

Technical Data

Housing	Aluminium IP66 / NEMA Type 4X	
Pressure range	-1 up to +16 bar (-14.5 up to +145 psi)	
Supply voltage/Signal output	Relay SPDT	19..230V AC, 19..55V DC
	Relay DPDT	19..230V AC, 19..36V/55V DC
	PNP	18..50V DC 3-wire
	2-wire without contact	19..230V AC/DC
	8/16mA; 4-20mA	12,5-30/36V DC 2-wire
Versions with certificates	ATEX, IEC-Ex, FM / CSA, TR-CU, INMETRO, CCC-Ex, KCs (Dust explosion-proof, Flameproof, Intrinsically safe, Increased safety)	
Process temperature	-40°C up to +150°C (-40°F up to + 302°F)	
Sensitivity	From 50 g/l (3 lb/ft ³) adjustable in 2 steps	
Process connection	R 1½" conical; NPT 1½"; various flanges available	
Vibration fork/extension	Stainless steel 1.4301 (SS304) or 1.4404 (SS316L) various lengths available	

Housing types



Installation

Mounting in downpipe as back up switch

Mounting in loading bellow as full detector

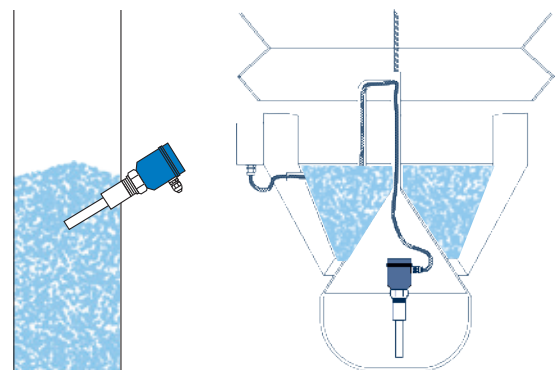

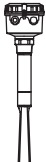



Table of content

	Page
Overview	2
Specifications	4
Applications	5

VN ..020 Short extension length	6
	

VN ..030 Pipe extension	8
	

VN ..040 Pipe extension (screwed)	10
	

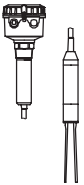
VN ..050 Cable extension	12
	

Options	14
Accessories	16
Dimensions	17
Detailed Ex-markings	21
Electrical installation	22
Spare parts Electronic modules	24

Wolf Process Automation Limited
 Tel: +353 45 831575
 Email: info@wpa.ie
 Web: www.wpa.ie

Subject to change.

All dimensions in mm (inches).

All prices in Euro (€) or USD (\$),
 excluding VAT.

All EURO prices are EXW Betzigau,
 all USD prices are EXW Memphis,
 excluding packaging costs.

Valid: From 01.01.2022 until 31.12.2022, unless otherwise agreed.

By publishing this selection list all other lists become invalid.

We assume no liability for typing errors.

Different variations to those specified are possible.
 Please contact our technical consultants.

Overview

- Level limit detection in bulk goods/ solids
- Compact unit
- Die-casted housing aluminium
- Wide range of applications, no maintenance
- Full, demand, empty detector
- ATEX, IEC-Ex, FM, CSA, TR-CU, INMETRO, KC, CCC
- 1935/2004/EC
- 2011/65/EU
- Gas Ex and Dust Ex approvals
- Food grade materials
- RoHS conform



Series

VN 1000	VN 2000	VN 5000	VN 6000
ATEX/ IEC-Ex/ TR-CU/ INMETRO/ KC/ CCC	ATEX/ IEC-Ex/ TR-CU/ INMETRO/ KC/ CCC	ATEX/ IEC-Ex/ FM/ CSA/ TR-CU/ INMETRO/ KC/ CCC	ATEX/ IEC-Ex/ FM/ CSA/ TR-CU/ INMETRO/ KC/ CCC
Small housing	Small housing	Spacious housing	Spacious housing
Short oscillating rods	Standard oscillating rods	Short oscillating rods	Standard oscillating rods
Sensitivity >50 g/l (3 lb/ft ³)	Sensitivity >20 g/l (1.2 lb/ft ³)	Sensitivity >50 g/l (3 lb/ft ³)	Sensitivity >20 g/l (1.2 lb/ft ³)
For extreme mech. load	Option >5g/l (0.3 lb/ft ³)	For extreme mech. load	Option >5g/l (0.3 lb/ft ³)
For mounting in down pipes	Vibrasil® <5 g/l (0.3 lb/ft ³)	For mounting in down pipes	Vibrasil® <5 g/l (0.3 lb/ft ³)
Advantageous design to avoid bridges		Advantageous design to avoid bridges	
Also for interface applications		Also for interface applications	

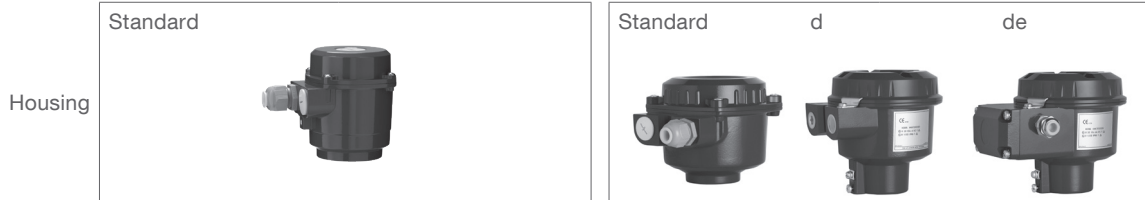

VN ..020
Short extension length



VN ..030
Pipe extension



Overview

VN ..040
 Pipe extension
 (screwed)

 Custom made
 pipe for flexible
 length

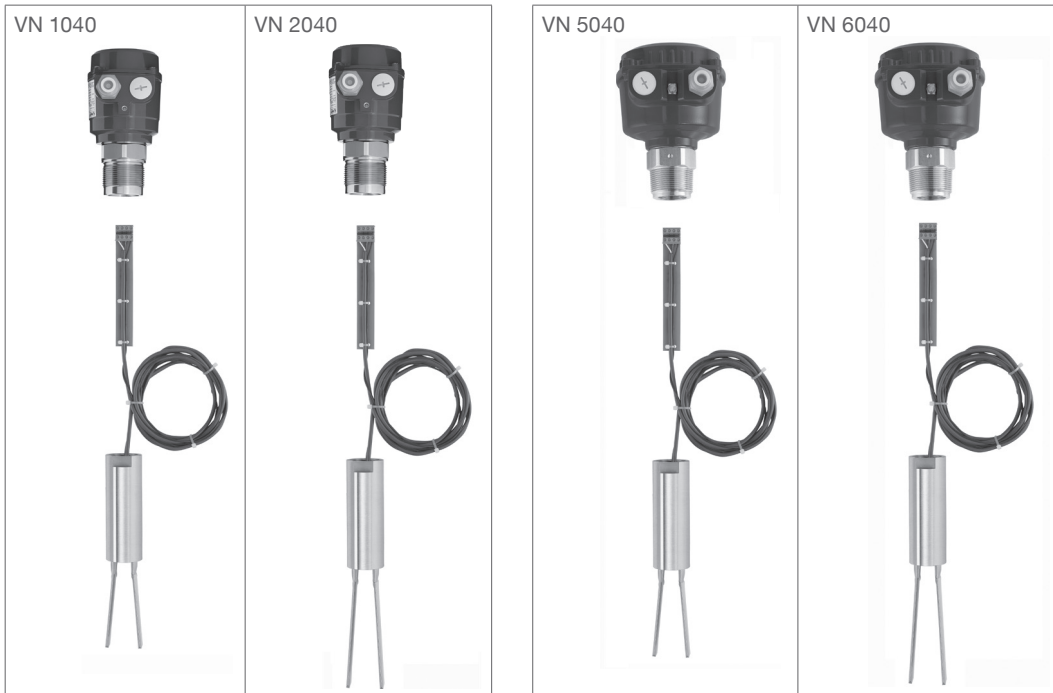

VN ..050
 Cable extension

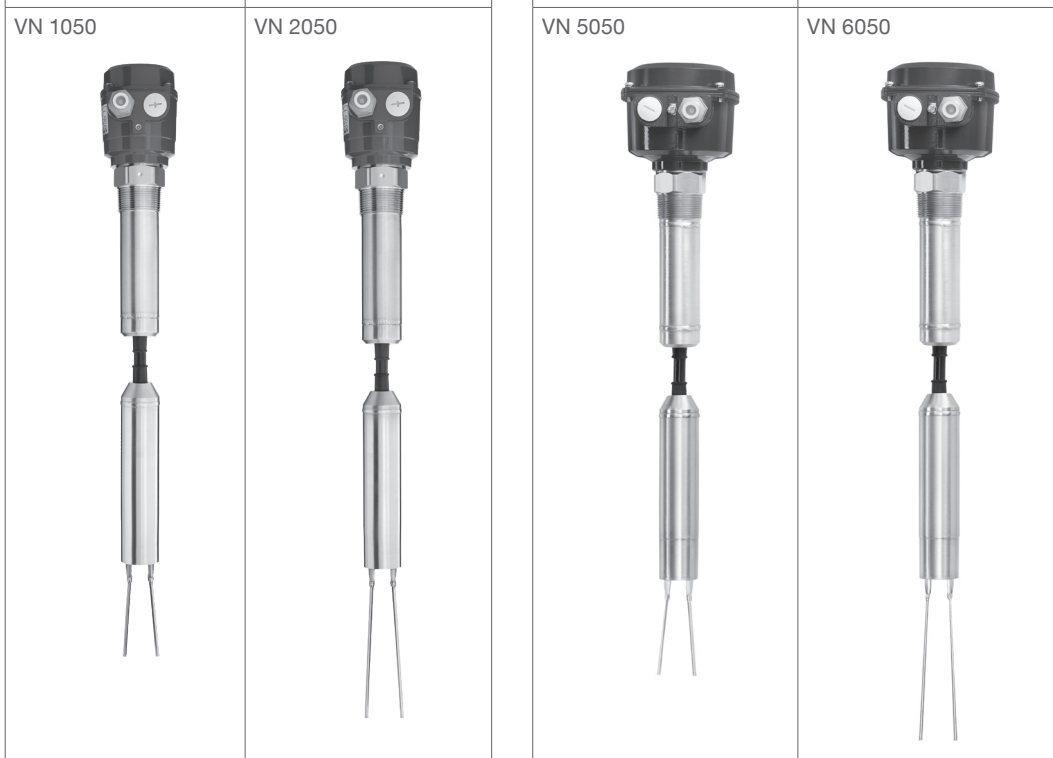

Specifications

Series		VN 1000	VN 2000	VN 5000	VN 6000	
Approvals	CE/ TR-CU	•	•	•	•	
	ATEX/ IEC-Ex/ INMETRO/ TR-CU/ KC/ CCC:					
	Zone 20/21	Dust Ignition Proof	•	•	•	•
	Zone 0	Intrinsic Safe	•	•	•	•
	Zone 1	Flameproof/ Increased Safety			•	•
	FM/ CSA:					
	General purp.				•	•
	Cl. II, III Div. 1	Dust Ignition Proof			•	•
	Cl. I Div. 1	Intrinsic Safe			•	•
	Cl. I Div. 1	Explosionproof			•	•
	Zone 0	Intrinsic Safe			•	•
Zone 1	Flameproof/ Increased Safety			•	•	
Electronics	Relais SPDT	19 .. 230 V AC 19 .. 55 V DC	•	•	•	•
	Relais DPDT	19 .. 230 V AC 19 .. 36 V/ 55 V DC	•	•	•	•
	PNP	18 .. 50 V DC	•	•	•	•
	2-wire without contact	19 .. 230 V AC/ DC	•	•	•	•
	NAMUR	IEC 60947-5-6 2-wire		•		•
	8/16 mA or 4-20 mA	12.5-30/36 V DC 2-wire	•	•	•	•
Extensions	VN ..020	Length of extension	165 mm (6.47")	235 mm (9.25")	165 mm (6.47")	235 mm (9.25")
		Ambient temperature	-40 .. +60°C (-40 .. +140°F)			
		Process temperature	-40 .. +150°C (-40 .. +302°F)			
		Process pressure	-1 .. +16 bar (-14.5 .. +232 psi)			
		Process connection material/ Extension ¹	1.4301 (304)/ 1.4541 (321) or 1.4404 (SS316L)/ (food grade)			
	VN ..030	Length of extension	300 .. 4,000 mm (11.8 .. 157")			
		Ambient temperature	-40 .. +60°C (-40 .. +140°F)			
		Process temperature	-40 .. +150°C (-40 .. +302°F)			
		Process pressure	-1 .. +16bar (-14.5 .. +232 psi)			
		Process connection material/ Extension ¹	1.4301 (304)/ 1.4541 (321) or 1.4404 (SS316L)/ (food grade)			
	VN ..040	Length of extension	1,500 mm (59") or 4,000 mm (157")			
		Ambient temperature	-40 .. +60°C (-40 .. +140°F)			
		Process temperature	-40 .. +150°C (-40 .. +302°F)			
		Process pressure	-1 .. +16bar (-14.5 .. +232 psi)			
		Process connection material/ Extension ¹	1.4305 (303)/ 1.4541 (321) or 1.4404 (SS316L)/ (food grade)			
	VN ..050	Length of extension	750 ... 20,000 mm (27.6" .. 787")			
		Ambient temperature	-25 .. +60°C (-13 .. +140°F)			
		Process temperature	-25 .. +80°C (-13 .. +176°F)			
		Process pressure	-1 .. +6 bar (-14.5 .. +87 psi)			
		Process connection material/ Extension ¹	1.4305 (303)/ 1.4541 (321) Cable isolation: PUR (no food grade)			

⁽¹⁾ The listed or higher-quality corrosion-resistant materials can be used.
 Filler materials are not listed.

Applications

Detection of solids

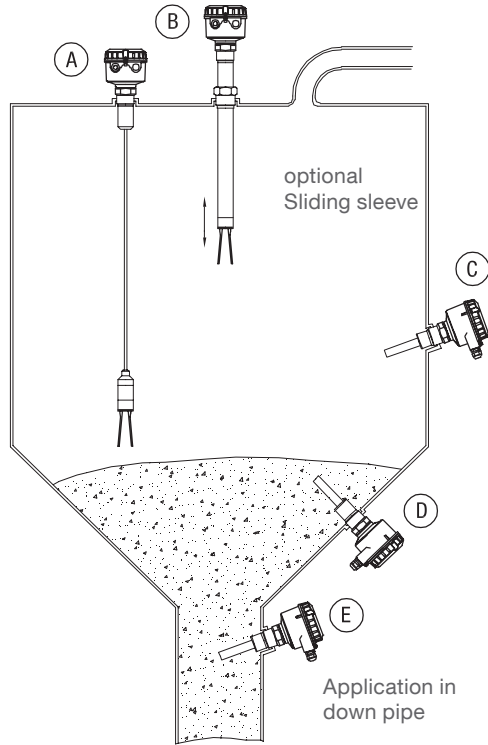

Detection of solids in water

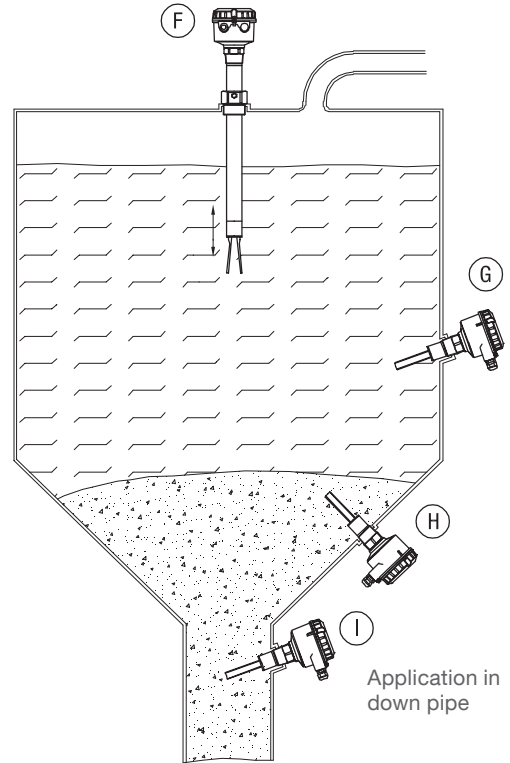

	(A)	(B)	(C)	(D)	(E)	(F)	(G)	(H)	(I)
VN 1020			•	•	•		•	•	•
VN 1030		•	•			•	•		
VN 1040		•	•						
VN 1050	•								
VN 2020			•	•	•				
VN 2030		•	•						
VN 2040		•	•						
VN 2050	•								
VN 5020			•	•	•		•	•	•
VN 5030		•	•			•	•		
VN 5040		•	•						
VN 5050	•								
VN 6020			•	•	•				
VN 6030		•	•						
VN 6040		•	•						
VN 6050	•								

VN ..020 Short extension length

VN 1020



VN 2020



VN 5020



VN 6020



Housings VN 5020/ 6020



Standard



d (flameproof)



de (flameproof/
increased safety)

Food grade materials

Cable entries (by default)

Depending on model selected, the following cable entries are supported (options see pos.23 on page 14):

Version:	Cable entries:
Flameproof (pos.2 T,D,L,5)	M20 x 1.5 (1x open conduit + 1x blind plug)
FM and CSA (pos.2 M,N,P,S,U)	NPT ½" tapered ANSI B1.20.1 (1x open conduit + 1x blind plug)
All other versions	M20 x 1.5 (1x screwed cable gland + 1x blind plug)

Dimensions see pages 17 - 20

pos.3
 Temperature extended shaft
 applications up to 150°C (302°F)

- 1 without
- 2 with

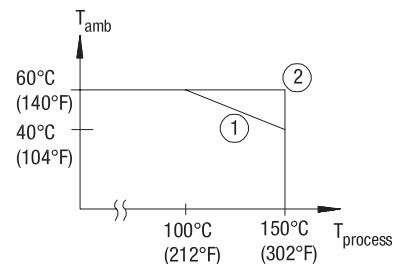
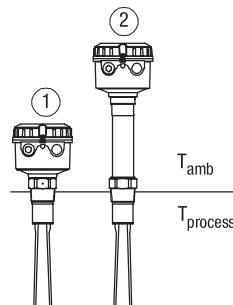

VN ..020 Short extension length

Basic type

VN 1020
 VN 2020
 VN 5020
 VN 6020

pos.2 **Certificate** (detailed Ex-markings: see page 20)

	Dust	Gas	Protection method
0	CE/ TR-CU	-	-
W	ATEX	Zone 20/21	Dust Ignition Proof
Y	ATEX	Zone 20/21	Intrinsic Safe/ Dust Ignition Proof
R	ATEX	Zone 20/21	Flameproof/ Increased Safety/ Dust Ignition Proof
T	ATEX	Zone 20/21	Flameproof/ Dust Ignition Proof
A	IEC-Ex	Zone 20/21	Dust Ignition Proof
B	IEC-Ex	Zone 20/21	Intrinsic Safe/ Dust Ignition Proof
C	IEC-Ex	Zone 20/21	Flameproof/ Increased Safety/ Dust Ignition Proof
D	IEC-Ex	Zone 20/21	Flameproof/ Dust Ignition Proof
M	FM/ CSA	-	General purpose
N	FM/ CSA	Cl. II, III, Div.1	Dust Ignition Proof
	CSA	A 20/21	
P	FM/ CSA	Cl. II, III, Div.1	Intrinsic Safe/ Dust Ignition Proof
	CSA	A 20/21	
S	FM/ CSA	Cl. II, III, Div.1	Flameproof/ Increased Safety/ Dust Ignition Proof
	CSA	A 20/21	
U	FM/ CSA	Cl. II, III, Div.1	Explosion Proof/ Dust Ignition Proof
	CSA	A 20/21	
E	TR-CU	Zone 20/21	Dust Ignition Proof
V	TR-CU	Zone 20/21	Intrinsic Safe/ Dust Ignition Proof
K	TR-CU	Zone 20/21	Flameproof/ Increased Safety/ Dust Ignition Proof
L	TR-CU	Zone 20/21	Flameproof/ Dust Ignition Proof
2	Further ⁽¹⁾	Zone 20/21	Dust Ignition Proof
3	Further ⁽¹⁾	Zone 20/21	Intrinsic Safe/ Dust Ignition Proof
4	Further ⁽¹⁾	Zone 20/21	Flameproof/ Increased Safety/ Dust Ignition Proof
5	Further ⁽¹⁾	Zone 20/21	Flameproof/ Dust Ignition Proof

pos.3 **Temperature extended shaft**

1 without (up to T_{process} = 150°C (302°F) at Tamb < 40°C (104°F))
 2 with (up to T_{process} = 150°C (302°F) at Tamb > 40°C (104°F))

pos.4 **Electronic module**

Available for certificates (pos.2)									
0	W/A/ E/2	Y/B/ V/3	R/C/ K/4	T/D/ L/5	M	N	P	S	U
E Relay SPDT									
L Relay DPDT	(1)		(3)	(3)		(1)		(3)	(3)
	(2)		(4)	(4)		(2)		(4)	(4)
D PNP									
K 2-wire without contact									
M NAMUR IEC 60947-5-6 2-wire									
N 8/16 mA or 4-20 mA 12.5 .. 36 V* DC 2-wire	(1)		(3)	(3)					
N 8/16 mA 12.5 .. 36 V DC 2-wire	(2)		(4)	(4)					

*30 V intrinsic safe
 (1) without pos.26 1/2 (3) with pos.3 1, without pos.26 1/2
 (2) with pos.26 1/2 (4) with pos.3 2 and/ or pos.26 1/2

pos.5 **Process connection**

A Thread R 1½", conical EN 10226
 B Thread NPT 1½", conical ANSI B1.20.1
 P Triclamp 2" (DN50) ISO 2852
 L Flange DN100 PN6, EN 1092-1 (max. 6 bar (87 psi))
 M Flange DN100 PN16, EN 1092-1
 S Flange 2" 150lbs ANSI B16.5 (max. 10 bar (145 psi))
 T Flange 3" 150lbs ANSI B16.5 (max. 10 bar (145 psi))
 U Flange 4" 150lbs ANSI B16.5 (max. 10 bar (145 psi))

pos.8 **Material of process connection/ extension "L"**

1 Stainless steel 1.4301 (304)/ Flange in 1.4541 (321)
 2 Stainless steel 1.4404 (316L)
 Vibrating rods polished, Ra ≤0.75 µm; PTFE coating on request

Basic type

	A					3	1	
Position	1	2	3	4	5	6	7	8

Order code

All positions are available with special design (use code "Z").
⁽¹⁾ Local certificates see option 20/ page 14

VN ..030 Pipe extension

VN 1030



VN 2030



VN 5030



VN 6030



Housings VN 5030/ 6030



Standard

d (flameproof)

de (flameproof/
increased safety)

Food grade materials

Cable entries (by default)

Depending on model selected, the following cable entries are supported (options see pos.23 on page 14):

Version:	Cable entries:
Flameproof (pos.2 T,D,L,5)	M20 x 1.5 (1x open conduit + 1x blind plug)
FM and CSA (pos.2 M,N,P,S,U)	NPT 1/2" tapered ANSI B1.20.1 (1x open conduit + 1x blind plug)
All other versions	M20 x 1.5 (1x screwed cable gland + 1x blind plug)

Dimensions see pages 17 - 20

pos.3
 Temperature extended shaft
 applications up to 150°C (302°F)

- 1 without
- 2 without and with extended socket
- 3 with

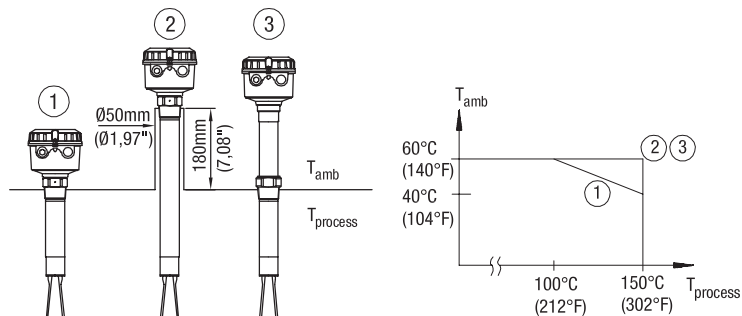

VN ..030 Pipe extension

Basic type

- VN 1030
- VN 2030
- VN 5030
- VN 6030

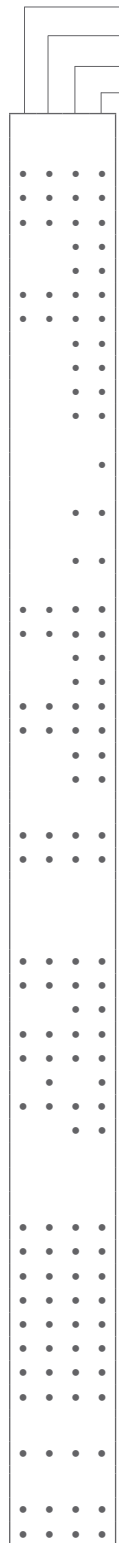

pos.2

Certificate (detailed Ex-markings: see page 20)

		Dust	Gas	Protection method
0	CE/ TR-CU	-	-	
W	ATEX	Zone 20/21	-	Dust Ignition Proof
Y	ATEX	Zone 20/21	Zone 0 and 0/1	Intrinsic Safe/ Dust Ignition Proof
R	ATEX	Zone 20/21	Zone 1	Flameproof/ Increased Safety/ Dust Ignition Proof
T	ATEX	Zone 20/21	Zone 1	Flameproof/ Dust Ignition Proof
A	IEC-Ex	Zone 20/21	-	Dust Ignition Proof
B	IEC-Ex	Zone 20/21	Zone 0 and 0/1	Intrinsic Safe/ Dust Ignition Proof
C	IEC-Ex	Zone 20/21	Zone 1	Flameproof/ Increased Safety/ Dust Ignition Proof
D	IEC-Ex	Zone 20/21	Zone 1	Flameproof/ Dust Ignition Proof
M	FM/ CSA	-	-	General purpose
N	FM/ CSA	Cl. II, III, Div.1	-	Dust Ignition Proof
	CSA	A 20/21		
P	FM/ CSA	Cl. II, III, Div.1	Cl. I Div.1/ Zone 0	Intrinsic Safe/ Dust Ignition Proof
	CSA	A 20/21		
S	FM/ CSA	Cl. II, III, Div.1	Zone 1	Flameproof/ Increased Safety/ Dust Ignition Proof
	CSA	A 20/21		
U	FM/ CSA	Cl. II, III, Div.1	Cl. I Div.1/ Zone 1	Explosion Proof/ Dust Ignition Proof
	CSA	A 20/21		
E	TR-CU	Zone 20/21	-	Dust Ignition Proof
V	TR-CU	Zone 20/21	Zone 0 and 0/1	Intrinsic Safe/ Dust Ignition Proof
K	TR-CU	Zone 20/21	Zone 1	Flameproof/ Increased Safety/ Dust Ignition Proof
L	TR-CU	Zone 20/21	Zone 1	Flameproof/ Dust Ignition Proof
2	Further ⁽¹⁾	Zone 20/21	-	Dust Ignition Proof
3	Further ⁽¹⁾	Zone 20/21	Zone 0 and 0/1	Intrinsic Safe/ Dust Ignition Proof
4	Further ⁽¹⁾	Zone 20/21	Zone 1	Flameproof/ Increased Safety/ Dust Ignition Proof
5	Further ⁽¹⁾	Zone 20/21	Zone 1	Flameproof/ Dust Ignition Proof

pos.3

Temperature extended shaft

- 1 without (up to T_{process} = 150°C (302°F) at T_{amb} < 40°C (104°F) or with extended socket)
- 2 with (up to T_{process} = 150°C (302°F) at T_{amb} > 40°C (104°F)) without extended socket)

pos.4

Electronic module

- E Relay SPDT 19 .. 230 V AC 19 .. 55 V DC
- L Relay DPDT 19 .. 230 V AC 19 .. 55 V DC
- 19 .. 230 V AC 19 .. 36 V DC
- D PNP 18 .. 50 V DC
- K 2-wire without contact 19 .. 230 V AC/ DC
- M NAMUR IEC 60947-5-6 2-wire
- N 8/16 mA or 4-20 mA 12.5 .. 36 V* DC 2-wire
- N 8/16 mA 12.5 .. 36 V DC 2-wire

Available for certificates (pos.2)									
0	W/A/ E/2	Y/B/ V/3	R/C/ K/4	T/D/ L/5	M	N	P	S	U
•	•		•	•	•		•	•	
•	(1)					(1)			
•	(2)					(2)			
•			•	•	•			•	•
•			•	•	•			•	•
•		•					•		
•	(1)	•							
•	(2)		•	•					

*30V intrinsic safe (1) without pos.26 1/2 (2) with pos.26 1/2

pos.5

Process connection

- A Thread R 1½", conical EN 10226
- B Thread NPT 1½", conical ANSI B1.20.1
- P Triclamp 2" (DN50) ISO 2852
- L Flange DN100 PN6, EN 1092-1 (max. 6 bar (87 psi))
- M Flange DN100 PN16, EN 1092-1
- S Flange 2" 150lbs ANSI B16.5 (max. 10 bar (145 psi))
- T Flange 3" 150lbs ANSI B16.5 (max. 10 bar (145 psi))
- U Flange 4" 150lbs ANSI B16.5 (max. 10 bar (145 psi))

pos.7

Length of extension "L"

- Z (starting from 0 mm) per 100 mm (3.94") or part thereof; min. 300 mm (11.8"), max. 4,000 mm (157")

pos.8

Material of process connection/ extension "L"

- 1 Stainless steel 1.4301 (304)/ Flange in 1.4541 (321)
 - 2 Stainless steel 1.4404 (316L)
- Vibrating rods polished, Ra ≤ 0.75 µm; PTFE coating on request

Further options and accessories: see page 14 - 16

Basic type

B
3
Z
-
L =
mm
← Order code

Position 1 2 3 4 5 6 7 8

All positions are available with special design (use code "Z").

⁽¹⁾ Local certificates see option 20/ page 14

VN ..040 Pipe extension (screwed)

VN 1040



VN 2040



VN 5040



VN 6040



Housings VN 5040/ 6040



Standard

d (flameproof)

de (flameproof/
increased safety)

Food grade materials

Cable entries (by default)

Depending on model selected, the following cable entries are supported (options see pos.23 on page 14):

Version:	Cable entries:
Flameproof (pos.2 T,D,L,5)	M20 x 1.5 (1x open conduit + 1x blind plug)
FM and CSA (pos.2 M,N,P,S,U)	NPT 1/2" tapered ANSI B1.20.1 (1x open conduit + 1x blind plug)
All other versions	M20 x 1.5 (1x screwed cable gland + 1x blind plug)

Dimensions

see pages 17 - 20

applications up to 150°C
(302°F)

- 1 without extended socket
- 2 with extended socket

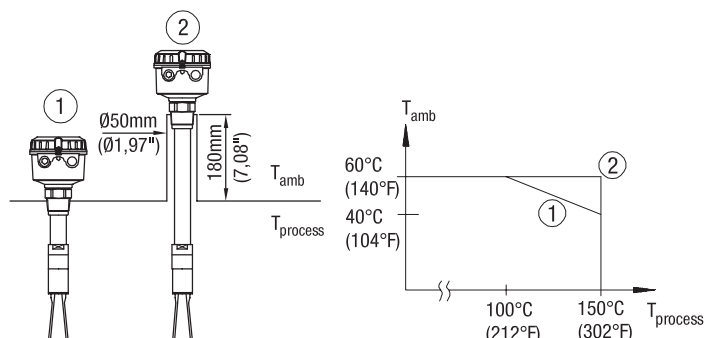

VN ..040 Pipe extension (screwed)

Basic type

- VN 1040
- VN 2040
- VN 5040
- VN 6040

pos.2		Certificate (detailed Ex-markings: see page 20)		
		Dust	Gas	Protection method
0	CE/ TR-CU	-	-	
W	ATEX	Zone 20/21	-	Dust Ignition Proof
Y	ATEX	Zone 20/21	Zone 0 and 0/1	Intrinsic Safe/ Dust Ignition Proof
R	ATEX	Zone 20/21	Zone 1	Flameproof/ Increased Safety/ Dust Ignition Proof
T	ATEX	Zone 20/21	Zone 1	Flameproof/ Dust Ignition Proof
A	IEC-Ex	Zone 20/21	-	Dust Ignition Proof
B	IEC-Ex	Zone 20/21	Zone 0 and 0/1	Intrinsic Safe/ Dust Ignition Proof
C	IEC-Ex	Zone 20/21	Zone 1	Flameproof/ Increased Safety/ Dust Ignition Proof
D	IEC-Ex	Zone 20/21	Zone 1	Flameproof/ Dust Ignition Proof
M	FM/ CSA	-	-	General purpose
N	FM/ CSA	Cl. II, III, Div.1	-	Dust Ignition Proof
	CSA	A 20/21		
P	FM/ CSA	Cl. II, III, Div.1	Cl. I Div.1/ Zone 0	Intrinsic Safe/ Dust Ignition Proof
	CSA	A 20/21		
S	FM/ CSA	Cl. II, III, Div.1	Zone 1	Flameproof/ Increased Safety/ Dust Ignition Proof
	CSA	A 20/21		
U	FM/ CSA	Cl. II, III, Div.1	Cl. I Div.1/ Zone 1	Explosion Proof/ Dust Ignition Proof
	CSA	A 20/21		
E	TR-CU	Zone 20/21	-	Dust Ignition Proof
V	TR-CU	Zone 20/21	Zone 0 and 0/1	Intrinsic Safe/ Dust Ignition Proof
K	TR-CU	Zone 20/21	Zone 1	Flameproof/ Increased Safety/ Dust Ignition Proof
L	TR-CU	Zone 20/21	Zone 1	Flameproof/ Dust Ignition Proof
2	Further ⁽¹⁾	Zone 20/21	-	Dust Ignition Proof
3	Further ⁽¹⁾	Zone 20/21	Zone 0 and 0/1	Intrinsic Safe/ Dust Ignition Proof
4	Further ⁽¹⁾	Zone 20/21	Zone 1	Flameproof/ Increased Safety/ Dust Ignition Proof
5	Further ⁽¹⁾	Zone 20/21	Zone 1	Flameproof/ Dust Ignition Proof

pos.4 Electronic module

		Available for certificates (pos.2)									
		0	W/A/ E/2	Y/B/ V/3	R/C/ K/4	T/D/ L/5	M	N	P	S	U
E	Relay SPDT	19 .. 230 V AC	19 .. 55 V DC								
L	Relay DPDT	19 .. 230 V AC	19 .. 55 V DC								
		19 .. 230 V AC	19 .. 36 V DC								
D	PNP	18 .. 50 V DC									
K	2-wire without contact	19 .. 230 V AC/ DC									
M	NAMUR IEC 60947-5-6	2-wire									
N	8/16 mA or 4-20 mA	12.5 .. 36 V* DC	2-wire								
N	8/16 mA	12.5 .. 36 V DC	2-wire								

*30 V intrinsic safe

pos.5 Process connection

- A Thread R 1½", conical EN 10226
- B Thread NPT 1½", conical ANSI B1.20.1
- P Triclamp 2" (DN50) ISO 2852
- L Flange DN100 PN6, EN 1092-1 (max. 6 bar (87 psi))
- M Flange DN100 PN16, EN 1092-1
- S Flange 2" 150lbs ANSI B16.5 (max. 10 bar (145 psi))
- T Flange 3" 150lbs ANSI B16.5 (max. 10 bar (145 psi))
- U Flange 4" 150lbs ANSI B16.5 (max. 10 bar (145 psi))

pos.7 Length of extension "L"

- L 1.500 mm (59") (cuttable cable length)
- M 4.000 mm (157") (cuttable cable length)

pos.8 Material of process connection/ extension "L"

- 1 Stainless steel 1.4305 (303)/ Flange in 1.4541 (321)
 - 2 Stainless steel 1.4404 (316L)
- Vibrating rods polished, Ra ≤0.75 µm; PTFE coating on request

Further options and accessories: see page 14 - 16

Basic type

	C	1	3				
Position	1	2	3	4	5	6	7

← **Order code**



All positions are available with special design (use code "Z").

⁽¹⁾ Local certificates see option 20/ page 14

VN ..050 Cable extension

VN 1050



VN 2050



VN 5050



VN 6050



Housings VN 5050/ 6050



Standard



d (flameproof)



de (flameproof/
increased safety)

Cable entries (by default)

Depending on model selected, the following cable entries are supported (options see pos.23 on page 14):

Version:	Cable entries:
Flameproof (pos.2 T,D,L,5)	M20 x 1.5 (1x open conduit + 1x blind plug)
FM and CSA (pos.2 M,N,P,S,U)	NPT ½" tapered ANSI B1.20.1 (1x open conduit + 1x blind plug)
All other versions	M20 x 1.5 (1x screwed cable gland + 1x blind plug)

Dimensions see pages 17 - 20

VN ..050 Cable extension

Basic type

- • • • • VN 1050
- • • • • VN 2050
- • • • • VN 5050
- • • • • VN 6050

pos.2 **Certificate** (detailed Ex-markings: see page 20)

	Dust	Gas	Protection method
0	CE/ TR-CU	-	-
W	ATEX Zone 20/21	-	Dust Ignition Proof
Y	ATEX Zone 20/21	Zone 0 and 0/1	Intrinsic Safe/ Dust Ignition Proof
R	ATEX Zone 20/21	Zone 1	Flameproof/ Increased Safety/ Dust Ignition Proof
T	ATEX Zone 20/21	Zone 1	Flameproof/ Dust Ignition Proof
A	IEC-Ex Zone 20/21	-	Dust Ignition Proof
B	IEC-Ex Zone 20/21	Zone 0 and 0/1	Intrinsic Safe/ Dust Ignition Proof
C	IEC-Ex Zone 20/21	Zone 1	Flameproof/ Increased Safety/ Dust Ignition Proof
D	IEC-Ex Zone 20/21	Zone 1	Flameproof/ Dust Ignition Proof
M	FM/ CSA	-	General purpose
N	FM/ CSA	-	Dust Ignition Proof
	CSA A 20/21		
P	FM/ CSA	Cl. I Div.1/ Zone 0	Intrinsic Safe/ Dust Ignition Proof
	CSA A 20/21		
S	FM/ CSA	Zone 1	Flameproof/ Increased Safety/ Dust Ignition Proof
	CSA A 20/21		
U	FM/ CSA	Cl. I Div.1/ Zone 1	Explosion Proof/ Dust Ignition Proof
	CSA A 20/21		
E	TR-CU Zone 20/21	-	Dust Ignition Proof
V	TR-CU Zone 20/21	Zone 0 and 0/1	Intrinsic Safe/ Dust Ignition Proof
K	TR-CU Zone 20/21	Zone 1	Flameproof/ Increased Safety/ Dust Ignition Proof
L	TR-CU Zone 20/21	Zone 1	Flameproof/ Dust Ignition Proof
2	Further ⁽¹⁾ Zone 20/21	-	Dust Ignition Proof
3	Further ⁽¹⁾ Zone 20/21	Zone 0 and 0/1	Intrinsic Safe/ Dust Ignition Proof
4	Further ⁽¹⁾ Zone 20/21	Zone 1	Flameproof/ Increased Safety/ Dust Ignition Proof
5	Further ⁽¹⁾ Zone 20/21	Zone 1	Flameproof/ Dust Ignition Proof

pos.4 **Electronic module**

		Available for certificates (pos.2)									
0	W/A/ E/2	Y/B/ V/3	R/C/ K/4	T/D/ L/5	M	N	P	S	U		
E	Relay SPDT	19 .. 230 V AC	19 .. 55 V DC								
L	Relay DPDT	19 .. 230 V AC	19 .. 55 V DC								
		19 .. 230 V AC	19 .. 36 V DC								
D	PNP	18 .. 50 V DC									
K	2-wire without contact	19 .. 230 V AC/ DC									
M	NAMUR IEC 60947-5-6	2-wire									
N	8/16 mA or 4-20 mA	12.5 .. 36 V* DC	2-wire								
N	8/16 mA	12.5 .. 36 V DC	2-wire								

*30 V intrinsic safe

- pos.5 **Process connection**
- • • • • A Thread R 1½", conical EN 10226
 - • • • • B Thread NPT 1½", conical ANSI B1.20.1
 - • • • • L Flange DN100 PN6, EN 1092-1 (max. 6 bar (87 psi))
 - • • • • M Flange DN100 PN16, EN 1092-1
 - • • • • S Flange 2" 150lbs ANSI B16.5
 - • • • • T Flange 3" 150lbs ANSI B16.5
 - • • • • U Flange 4" 150lbs ANSI B16.5

pos.7 **Length of extension "L"**
 Z (starting from 0 mm) per 100 mm (3.94") or part thereof; min./ max. see below

- pos.8 **Material of process connection/ extension "L"**
- • • • • 1 Stainless steel 1.4305 (303)/ Flange in 1.4541 (321)
 - • • • • 2 Stainless steel 1.4404 (316L)on request
- Vibrating rods polished, Ra ≤0.75 µm; PTFE coating on request

Further options and accessories: see page 14 - 16

Extension "L":
 min. 750 mm (29,6")
 max. 7,000 mm (276") for VN 1050/ 5050
 max. 20,000 mm (787") for VN 2050/ 6050
 max. 10,000 mm (394") for VN 2050/ 6050 with pos.4 M

Basic type

	D	1	3	Z	1
Position	1	2	3	4	5

- **L =** mm ← **Order code**

All positions are available with special design (use code "Z").

⁽¹⁾ Local certificates see option 20/ page 14

Options

VN 1020	VN 2020	VN 5020	VN 6020	VN 1030	VN 2030	VN 5030	VN 6030	VN 1040	VN 2040	VN 5040	VN 6040	VN 1050	VN 2050	VN 5050	VN 6050			
•	•	•	•	•	•	•	•	•	•	•	•	•	•	•	•	pos.11 x	Guarantee extension to 5 years	•
																	Local certificates (Zone and type of protection acc. to selection in pos.2 2 to pos.2 5)	
																pos.20 a	INMETRO	•
																pos.20 b	KC	•
																pos.20 c	CCC	•
																pos.21	Weather protection cover	•
																	(for Ex only approved for Zone 2 or 22 or Div. 2)	
																	Mounting set for flange mounting	
																pos.22 c		•
																pos.22 d		•
																pos.22 e		•
																pos.22 f		•
																	* material stainless steel A2 **max. 250°C (482°F), material not food grade	
																	Cable entry Selection of the following options only necessary, if a deviation from the default cable gland/ conduit is required:	
																pos.23 x	M20 x 1.5 2x screwed cable gland	•
																pos.23 y	M20 x 1.5 1x screwed cable gland +1x blind plug	•
																pos.23 a	NPT ½" tapered ANSI B1.20.1 (1x conduit + 1x Ex-d blind plug)	•
																pos.23 b	NPT ¾" tapered ANSI B1.20.1 (1x conduit + 1x Ex-d blind plug)on req.	•
																	Sliding sleeve (max. 16 bar (232 psi), max. 150°C (302°F)) process connection as follows or flange as chosen; with Triclamp on request Not for Ex applications Zone 0/1 (Cat. 1/2) with separation wall	
																pos.25 w	G2" ISO 228 material 1.4305 (303)	•
																pos.25 x	G2" ISO 228 material 1.4404 (316L)	•
																pos.25 u	NPT 2" ANSI B1.20.1 material 1.4305 (303)	•
																pos.25 v	NPT 2" ANSI B1.20.1 material 1.4404 (316L)	•
																pos.25 t	Flange 1.4305/ 1.4541 (303/321)	•
																pos.25 s	Flange 1.4404 (316L)	•
																	Special versions	
																pos.26 x	Enhanced sensitivity (>5 g/l (0.3 lb/ft³))	•
																pos.26 a	Vibrasil® 70 (sensitivity <5 g/l (0.3 lb/ft³))	•
																pos.26 b	Vibrasil® 90 (sensitivity <5g/l (0.3 lb/ft³))	•
																pos.26 c	Adjustable sensitivity for interface applications (only with CE)	•
																pos.26.1	Separate housing cable length 1.5 m (59") including hexagon nut	•
																pos.26.2	Separate housing cable length 4.0 m (157") including hexagon nut	•
																pos.26.3	Separate housing cable length 1.5 m (59") including hexagon nut and angle bracket (aluminium)	•
																pos.26.4	Separate housing cable length 4.0 m (157") including hexagon nut and angle bracket (aluminium)	•
																	Signal lamp	
																pos.27 a	LED, mounted in cable entry M20 x 1.5, green	•
																pos.27 c	LED, mounted in cable entry M20 x 1.5, red	•
																pos.27 b	LED (glass window in lid)	•
																	Plug	
																pos.29 x	Valve connector (incl. mating plug) 4-pole (incl. PE)	•

- 1 Available for pos.2 2
- 2 Available for pos.2 2, 5
- 3 Available for pos.2 2, 3
- 4 Available for pos.2 2, 3, 5
- 5 Available for all versions except explosionproof/ flameproof and increased safety versions (pos.2 R,T,C,D,S,U,K,L,4,5).
- 6 Available for all versions except flameproof version (pos.2 T,D,U,L,5).
- 7 Available for FM/ CSA versions (pos.2 M,N,P,S) except flameproof version (pos.2 U).
- 8 Available for all versions except for FM/ CSA versions (pos.2 M,N,P,S,U).
- 9 Flange and material as selected in pos.5 and pos.8.
- 10 Available only with electronic module "Relais SPDT" (pos.4 E).
Due to the increased vibrating surface the Vibrasil® 70 is even more sensitive than the Vibrasil® 90.
- 11 Available for all versions. Electronic module "8/16 mA" and "8/16 mA or 4-20 mA" (pos.4 N) not for FM/ CSA (pos.2 M,N,P,S,U).
- 12 Available for CE (pos.2 0), not in combination with weather protection cover (pos.21) and cable entries pos.23 x,a,b.
For electronic module Relais SPDT and DPDT (pos.4 E,L) 2 LED's (24V, 80-260V) will be delivered. For PNP (pos.4 D) a 24 V LED will be delivered. For other electronics on request.
- 13 Available for all versions except explosionproof/ flameproof version (pos.2 R,T,C,D,S,U,K,L,4,5), not with weather protection cover (pos.21).
- 14 Available only for CE (pos.2 0).



Options

pos.25
Sliding sleeve

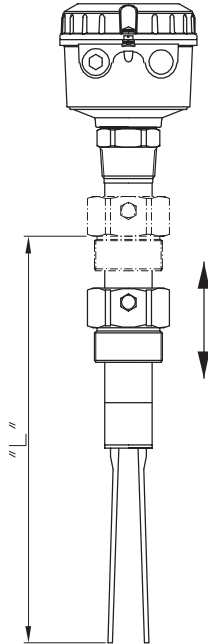

pos.26 x
Enhanced
sensitivity

pos.26 b
Vibrasil® 90

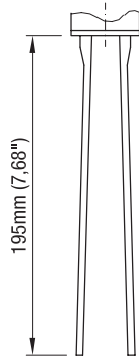

pos.26 1/2
Separate housing
without angle bracket

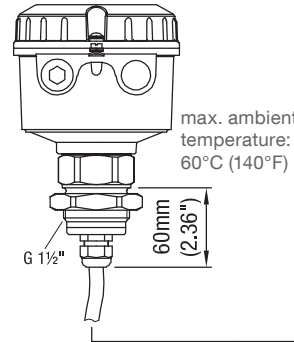

pos.26 3/4
Separate housing
with angle bracket

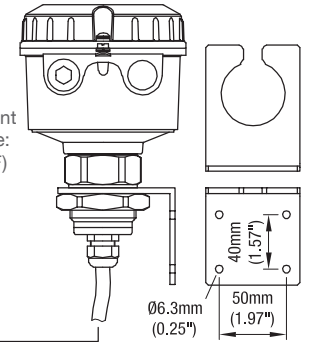

max. ambient temperature:
60°C (140°F)

60mm (2.36")

Ø10mm (0.39")

min. bending radius of cable:
50 mm (2")

grounding terminal for version with Ex approval

max. Process temperature:
150°C (302°F)
(Ex 110°C (230°F))

pos.26 a
Vibrasil® 70

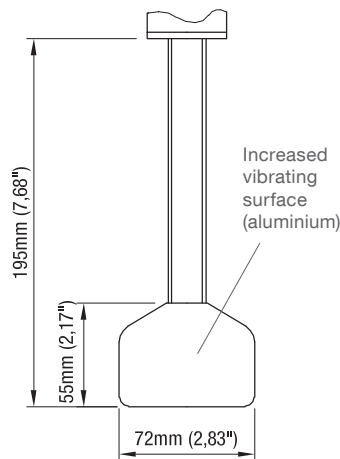

pos.21
Weather protection cover

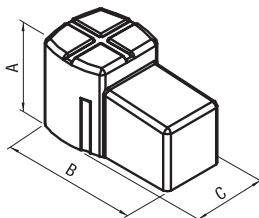

	VN 10..0	VN 50..0
	VN 20..0	VN 60..0
A	100 mm (3.94")	130 mm (5.12")
B	165 mm (6.5")	200 mm (7.87")
C	88 mm (3.46")	125 mm (4.92")

pos.29
Valve connector

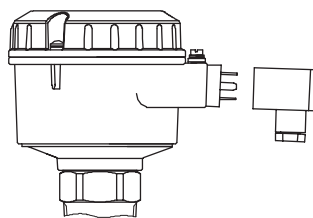

Signal lamp

pos.27 a,c
LED, mounted in cable entry M20 x 1.5

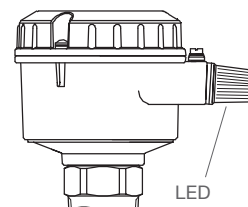

pos.27 b
LED (glass window in lid)

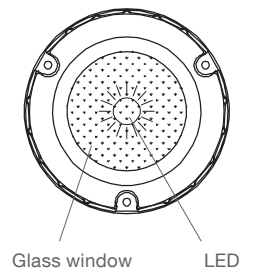

Options / Accessories

Accessories

Minimum order value for separate orders of spare parts or accessories is 75 €.

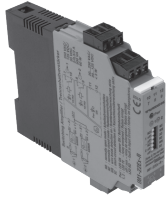

NAMUR Isolating Switching Amplifier Protection method [EEx ia] IIC
 (for Electronic module pos.4 M)

Terminal housing. Switchable signal output logic. Each channel has one independent output.

Channels	Signal output	Monitoring*	Supply	Manufacturer/ Type
				Turck
1	Relay (2x SPST)	x	20 - 125 V DC, 20 - 250 V AC	IM1-12EX-R
	2 transistor outputs (short-circuit proof, floating)	x		IM1-12EX-T
2	Relay (2x SPST)	x	20 - 125 V DC, 20 - 250 V AC	IM1-22EX-R
	2 transistor outputs (short-circuit proof, floating)	x		IM1-22EX-T
4	Relais (4x SPST)	x	20 - 125 V DC, 20 - 250 V AC	IM1-451EX-R
	4 transistor outputs (short-circuit proof, floating)	x		IM1-451EX-T

* Input circuit monitoring for wire-break, partial for short-circuit.
 Partial additional monitoring signal output.

Price on request



8/16 mA Limit Value Monitor
 (for Electronic module pos.4 N)

Limit Value Monitor Type IM43-13-R

Input: 1 channel 4-20 mA

Output: 3 Limit Value Relays for monitoring of 3 limit values of a current signal.

Terminal housing. Supply: 20 - 125 V DC, 20 - 250 V AC. Manufacturer: Turck.

Use in Hazardous Locations only with additional connected Isolating Transducer IM33.

Isolating Transducer Type IM33-11Ex-Hi/ 24 V DC (1 channel)

Isolating Transducer Type IM33-11Ex-Hi/ 24 V DC (2 channels)

Protection method [EEx ia] IIC.

Terminal housing.

Input/ output: 0/4-20 mA (galvanic isolated). Supply: 19 - 29 V DC.

Price on request

Dimensions

Housing versions

Series VN 1000/ 2000

Standard

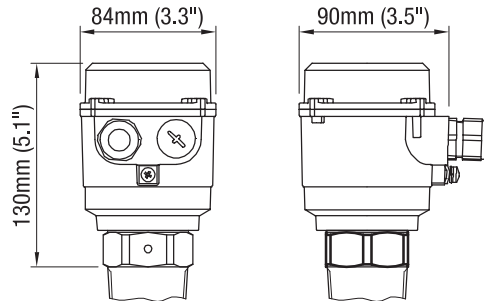

Series VN 5000/ 6000

Standard

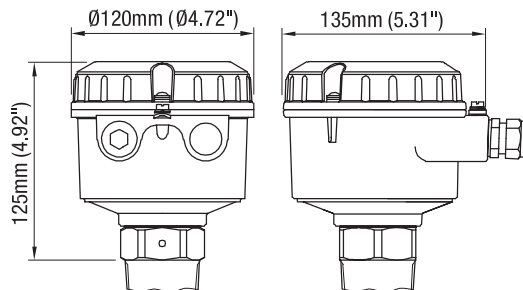

de

Explosionproof with
increased safety
terminal box

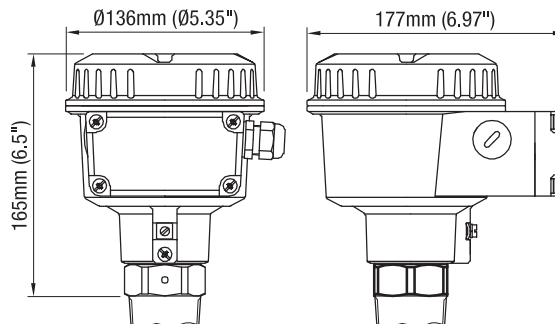

d

Flameproof/
explosionproof

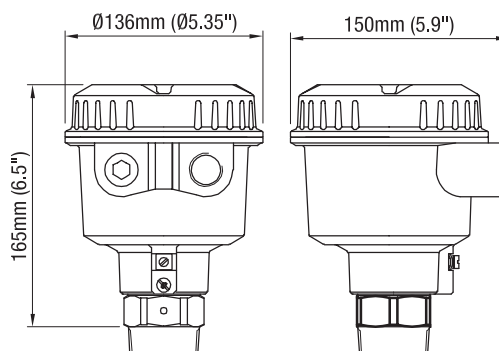

Dimensions

Extensions

VN ..020

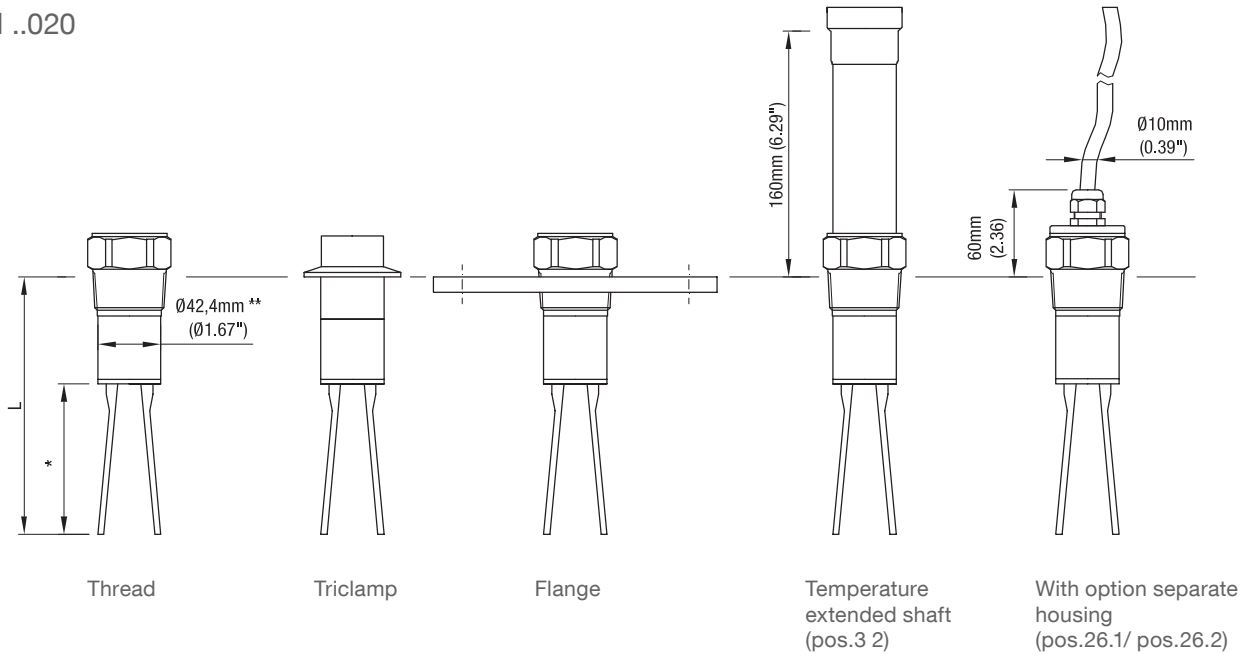

	L	
	without option	with option: Enhanced sensitivity (pos.26 x) Vibrasil® 70 (pos.26 a) Vibrasil® 90 (pos.26 b)
VN 1020 VN 5020	165 mm (6.5")	
VN 2020 VN 6020	235 mm (9.25")	260 mm (10.24")

* see page 19 bottom right
 ** welding seam max. $\varnothing 43.8$ mm (1.72")

VN ..030

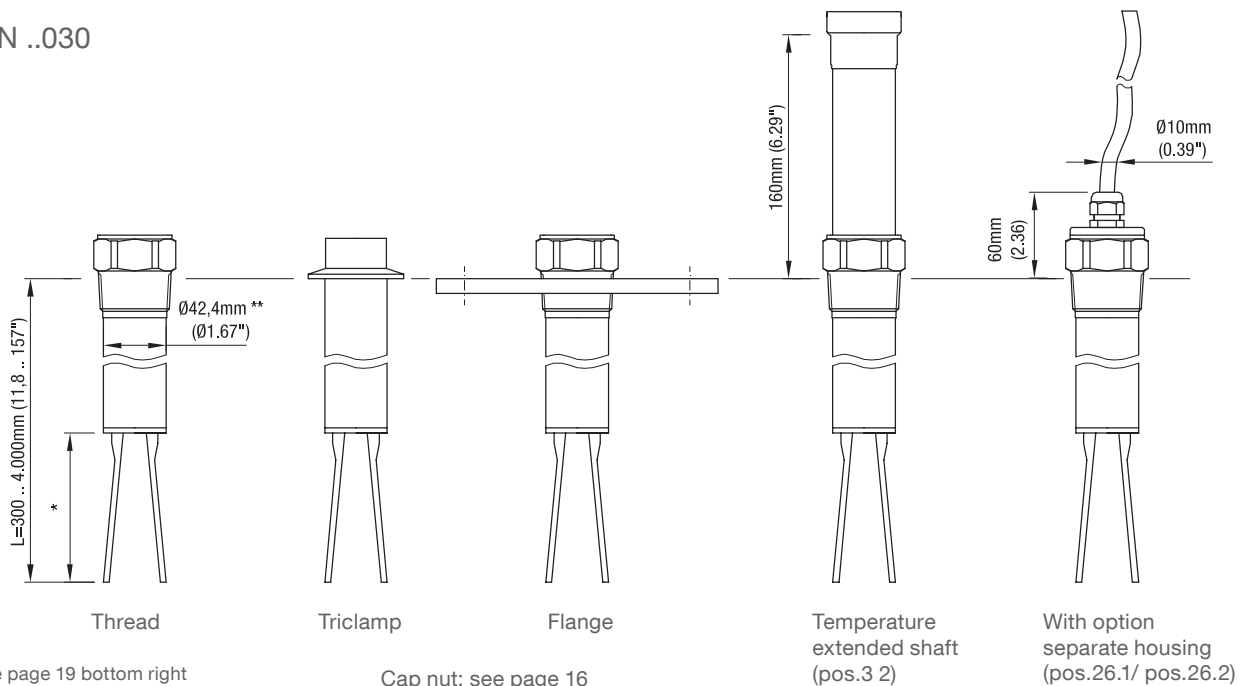

* see page 19 bottom right
 ** welding seam max. $\varnothing 43.8$ mm (1.72")

Cap nut: see page 16

Dimensions

VN ..040

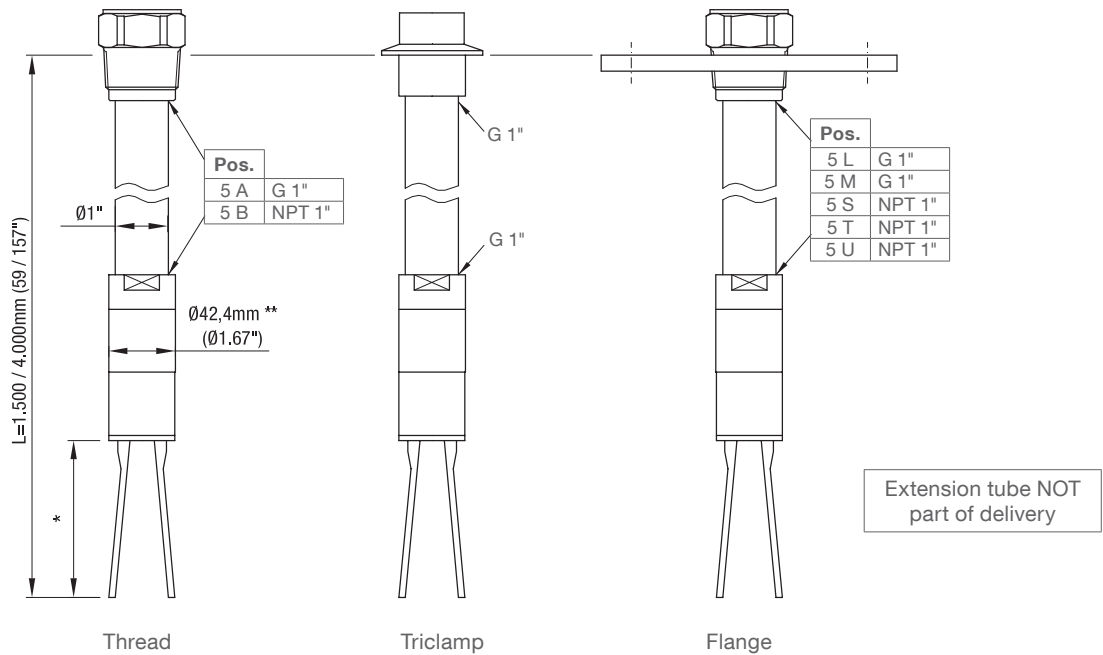

* see below right
 ** welding seam max. \varnothing 43.8 mm (1.72")

VN ..050

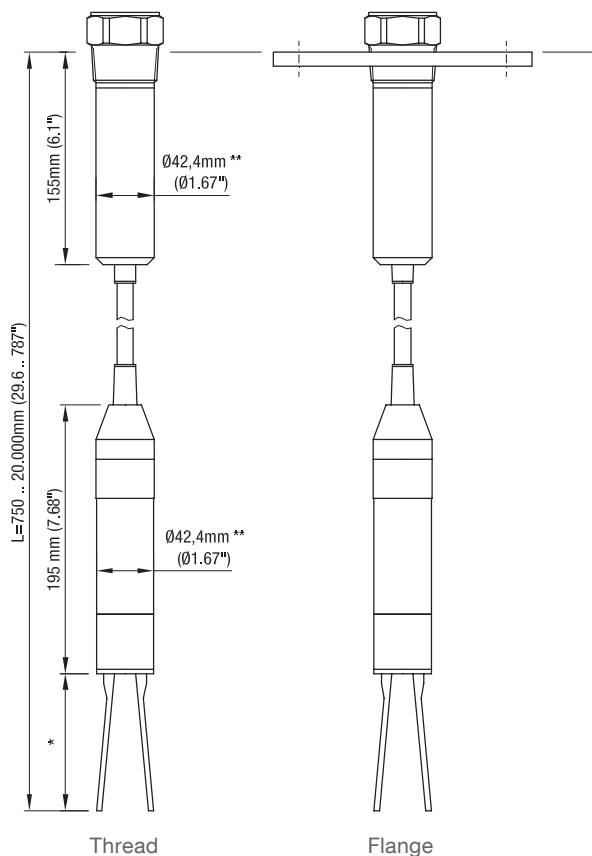

* see below right
 ** welding seam max. \varnothing 43.8 mm (1.72")

* Length of oscillating rods

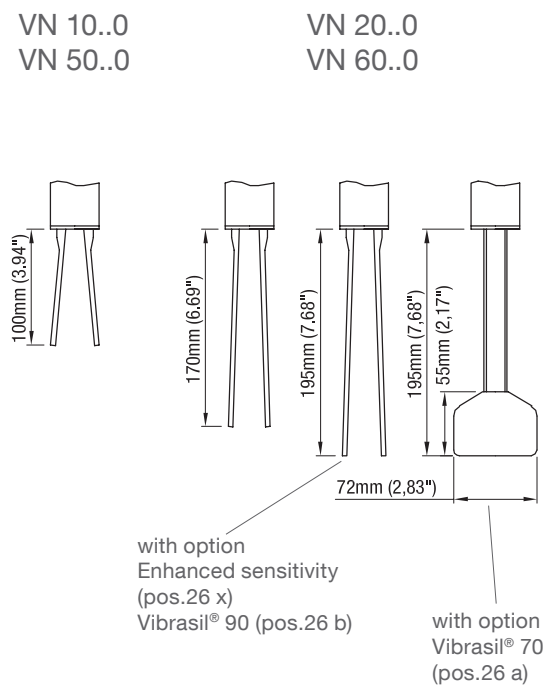

Dimensions

Flanges

Code	type	number of holes	d2	Lk	D	T (thickness)
L	Flange DN100 PN6	4	18 mm (0.71")	170 mm (6.69")	210 mm (8.27")	16 mm (0.63")
M	Flange DN100 PN16	8	18 mm (0.71")	180 mm (7.09")	220 mm (8.66")	20 mm (0.79")
S	Flange 2" 150lbs	4	19.1 mm (0.75")	120.7 mm (4.75")	152.4 mm (6.01")	19.1 mm (0.75")
T	Flange 3" 150lbs	4	19.1 mm (0.75")	152.4 mm (6.01")	190.5 mm (7.5")	23.9 mm (0.94")
U	Flange 4" 150lbs	8	19.1mm (0.75")	190.5mm (7.5")	228.6mm (9")	23.9mm (0.94")

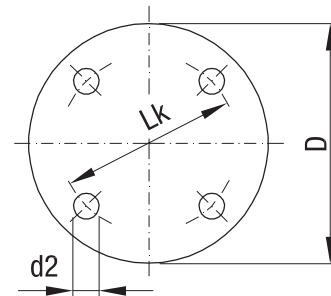

Detailed Ex-markings

Code	Certificate	Housing
pos.2 0	CE	Standard
pos.2 W	ATEX II 1/2D Ex ta/tb IIIC T! Da/Db	Standard
pos.2 Y	ATEX II 1G Ex ia IIC T! Ga and 1/2G Ex ia IIC T! Ga/Gb ATEX II 1/2D Ex ta/tb IIIC T! Da/Db	Standard
pos.2 R	ATEX II 2G Ex db eb ia* IIC T! Gb and ATEX II 1/2D Ex ta/tb IIIC T! Da/Db	de
pos.2 T	ATEX II 2G Ex db ia* IIC T! Gb and ATEX II 1/2D Ex ta/tb IIIC T! Da/Db	d
pos.2 A	IEC-Ex ta/tb IIIC T! Da/Db	Standard
pos.2 B	IEC-Ex ia IIC T! Ga and Ex ia IIC T! Ga/Gb IEC-Ex ta/tb IIIC T! Da/Db	Standard
pos.2 C	IEC-Ex db eb ia* IIC T! Gb and IEC-Ex ta/tb IIIC T! Da/Db	de
pos.2 D	IEC-Ex db ia* IIC T! Gb and IEC-Ex ta/tb IIIC T! Da/Db	d
pos.2 M	FM/ CSA general purpose	Standard
pos.2 N	FM/ CSA DIP Cl. II, III Div. 1 Gr. E,F,G CSA Ex DIP A20/21	Standard
pos.2 P	FM/ CSA IS Cl. I, II, III Div. 1 Gr. A-G FM Cl. I Zone 0 and 0/1 AEx ia IIC CSA Cl. I Zone 0 and 0/1 Ex ia IIC and CSA Ex DIP A20 and A20/21	Standard
pos.2 S	FM Cl. I Zone 1 AEx de [ia]* IIC and FM/ CSA Cl. II,III Div. 1 Gr. E,F,G CSA Cl. I Zone 1 Ex de [ia]* IIC and CSA Ex DIP A20/21	de
pos.2 U	FM XP-IS Cl. I,II,III Div. 1 Gr. B-G* and FM Cl. I Zone 1 AEx d [ia] IIC* CSA XP-IS Cl. I,II,III Div. 1 Gr. B-G* CSA Cl. I Zone 1 Ex d [ia]* IIC and CSA Ex DIP A20/21	d
pos.2 E	TR-CU Ex ta/tb IIIC T120°C...T150°C Da/Db X	Standard
pos.2 V	TR-CU 0Ex ia IIC T6...T3 Ga X and Ga/Gb Ex ia IIC T6...T3 X Ex ta/tb IIIC T80°C...T150°C Da/Db X	Standard
pos.2 K	TR-CU 1Ex d e [ia]* IIC T4...T3 Gb X Ex ta/tb IIIC T120°C...T150°C Da/Db X	de
pos.2 L	TR-CU 1Ex d [ia]* IIC T4...T3 Gb X Ex ta/tb IIIC T120°C...T150°C Da/Db X	d
pos.2 2	+pos.20 a INMETRO Ex ta/tb IIIC T120°C...T150°C Da/Db IP6X	Standard
pos.2 3	+pos.20 a INMETRO Ex ia IIC T6...T3 Ga IP6X and Ex ia IIC T6...T3 Ga/Gb IP6X Ex ta/tb IIIC T80°C...T150°C Da/Db IP6X	Standard
pos.2 4	+pos.20 a INMETRO Ex db eb [ia Ga]* IIC T4...T3 Gb IP66 Ex ta/tb IIIC T120°C...T150°C Da/Db IP6X	de
pos.2 5	+pos.20 a INMETRO Ex db [ia Ga]* IIC T4...T3 Gb IP66 Ex ta/tb IIIC T120°C...T150°C Da/Db IP6X	d
pos.2 2	+pos.20 b KC Ex t IIIC T!	Standard
pos.2 5	+pos.20 b KC Ex d [ia] IIC T! Ex t IIIC T!	d
pos.2 2	+pos.20 c CCC Ex tD A21 IP6X T!	Standard
pos.2 3	+pos.20 c CCC Ex ia IIC T! Ga and Ex ia IIC T! Ga/Gb Ex tD A21 IP6X T!	Standard
pos.2 5	+pos.20 c CCC Ex d IIC T! Ex tD A21 IP6X T!	d

* ia or IS is not available for versions VN .020 without temperature extended shaft (pos.3 1).
 In this case no intrinsic safe connection between Electronic module and Vibrating fork is used).

Electrical installation

Universal voltage

Relay SPDT

Power supply:

19 .. 230 V 50 - 60 Hz +10% 8 VA
 19 .. 55 V DC +10% 1.5 W

Signal output:

Floating relay SPDT

VN 1000/ 2000:

AC max. 253 V, 4 A, 500 VA at cos Phi = 1
 DC max. 253 V, 4 A, 60 W

VN 5000/ 6000:

AC max. 250 V, 8 A, non inductive
 DC max. 30 V, 5 A, non inductive

Fuse: max. 10 A, slow or fast, HBC, 250 V

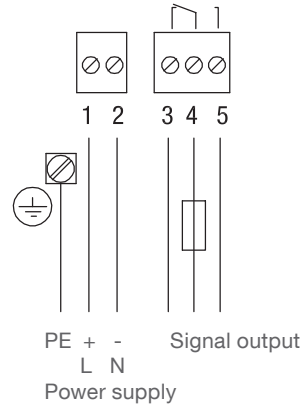

Universal voltage

Relay DPDT

Power supply:

19 .. 230 V 50 - 60 Hz +10% 18 VA
 19 .. 55 V (36 V*) DC +10% 2 W

Signal output:

Floating relay DPDT

VN 1000/ 2000:

AC max. 253 V, 4 A, 500 VA at cos Phi = 1
 DC max. 253 V, 4 A, 60 W

VN 5000/ 6000:

AC max. 250 V, 8 A, non inductive
 DC max. 30 V, 5 A, non inductive

Fuse: max. 10 A, slow or fast, HBC, 250 V

* Version with intrinsic safe connection between electronic module and vibration fork (see pos.4 in price list)

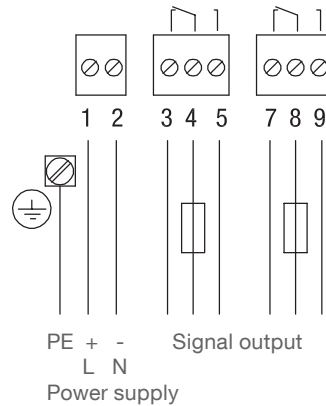

3-wire

PNP

Power supply:

18 .. 50 V DC +10% 1.5 W

Fuse: max. 4 A, slow or fast, HBC, 250 V

Signal output:

max. 0.4 A

Load for example:

PLC, relay, contactor, bulb

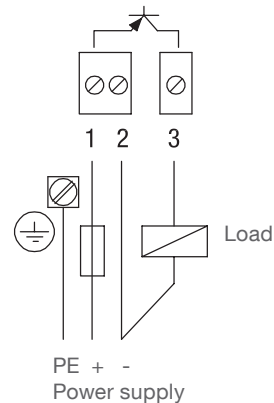

Electrical installation

2-wire

without contact

Power supply:

19 .. 230V 50/ 60 Hz +10% 1.5 VA
 19 .. 230V DC +10% 1 W

Load:

min. 10 mA
 max. 0.5 A permanent
 (detailed ratings see
 "Technical data")

Load for example:
 relay, contactor, bulb

Fuse: max. 4 A, slow or fast, HBC, 250 V

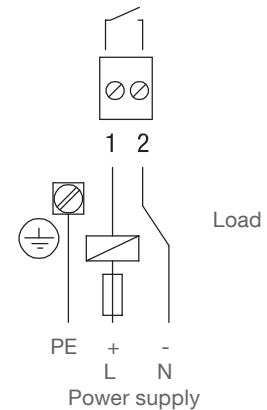

NAMUR

IEC 60947-5-6

Power supply:

ca. 7 .. 9 V DC
 intrinsic safe
 (spec. IEC 60947-5-6)

<1mA or >2.2 mA
 (spec. IEC 60947-5-6)

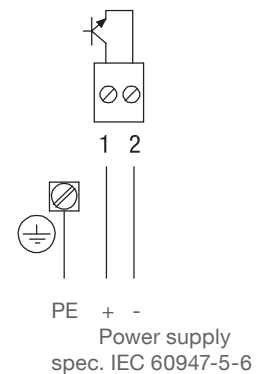

8/16 mA or 4-20 mA

Power supply:

Non intrinsic safe version:
 12.5 .. 36 V DC +0%

Intrinsic safe version:
 12.5 .. 30 V DC +0%

Signal output

Setting 8/16 mA:
 8 mA or 16 mA

Setting 4-20 mA:
 Output current depends on the
 vibration amplitude of the fork: 6 mA for
 dampened vibration and 20 mA for full
 vibration.

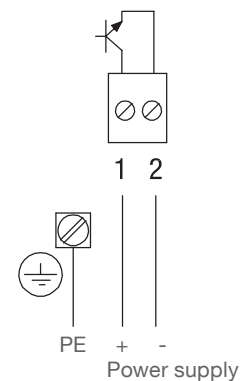

8/16 mA

Power supply:

12.5 .. 36 V DC +0%

Signal output

8 mA or 16 mA

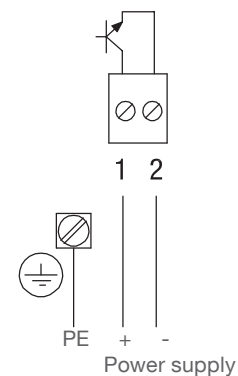

Spare parts

Electronic modules VN 1000/ VN 5000

Minimum order value for separate orders of spare parts or accessories is 75 €.

Electronic module	Electronic module number	VN 1020	VN 1020 VN 1030 VN 1040 separate housing	VN 1030 VN 1040	VN 1050	VN 5020	VN 5020 temp. extended shaft	VN 5020 VN 5030 separate housing	VN 5030 VN 5040	VN 5050	Prices Electronic module
Relay (SPDT) 19 .. 230 V AC 19 .. 55 V DC	pl400932	0, W, A, E, 2	0	0, W, A, E, 2	0	0, M, W, A, N, R, C, S, T, D, U, E, K, L, 2, 4, 5	0, M, W, A, N, E, 2	0, M	0, M, W, A, N, E, 2	0, M	•
	pl400120 *		W, A, E, 2		W, A, E, 2	R, C, S, T, D, U, K, L, 4, 5		W, A, N, R, C, S, T, D, U, E, K, L, 2, 4, 5	R, C, S, T, D, U, K, L, 4, 5	W, A, N, R, C, S, T, D, U, E, K, L, 2, 4, 5	•
Relay (DPDT) 19 .. 230 V AC 19 .. 55 V DC	pl400247	0, W, A, E, 2	0	0, W, A, E, 2	0	0, M, W, A, N, R, C, S, T, D, U, E, K, L, 2, 4, 5	0, M, W, A, N, E, 2	0, M	0, M, W, A, N, E, 2	0, M	•
	pl400052 *		W, A, E, 2		W, A, E, 2	R, C, S, T, D, U, K, L, 4, 5		W, A, N, R, C, S, T, D, U, E, K, L, 2, 4, 5	R, C, S, T, D, U, K, L, 4, 5	W, A, N, R, C, S, T, D, U, E, K, L, 2, 4, 5	•
PNP 18 .. 50 V DC	pl400246	0, W, A, E, 2	0	0, W, A, E, 2	0	0, M, W, A, N, R, C, S, T, D, U, E, K, L, 2, 4, 5	0, M, W, A, N, E, 2	0, M	0, M, W, A, N, E, 2	0, M	•
	pl400123*		W, A, E, 2		W, A, E, 2	R, C, S, T, D, U, K, L, 4, 5		W, A, N, R, C, S, T, D, U, E, K, L, 2, 4, 5	R, C, S, T, D, U, K, L, 4, 5	W, A, N, R, C, S, T, D, U, E, K, L, 2, 4, 5	•
2-wire without contact 19 .. 230 V AC/DC	pl400242	0, W, A, E, 2	0	0, W, A, E, 2	0						•
	pl400122						0, M, W, A, N, R, C, S, T, D, U, E, K, L, 2, 4, 5	0, M	0, M, W, A, N, E, 2	0, M	•
8/16 mA 2-wire	pl400122 *		W, A, E, 2		W, A, E, 2						•
	pl400062*		W, A, E, 2		W, A, E, 2	R, C, S, T, D, U, K, L, 4, 5		W, A, N, R, C, S, T, D, U, E, K, L, 2, 4, 5	R, C, S, T, D, U, K, L, 4, 5	W, A, N, R, C, S, T, D, U, E, K, L, 2, 4, 5	•
8/16 mA or 4-20 mA 2-wire intrinsic safe	pl400093	0	0	0	0						•
	pl400090 **	W, A, Y, B, E, V, 2, 3	Y, B, V, 3	W, A, Y, B, E, V, 2, 3	Y, B, V, 3	W, A, Y, B, R, C, T, D, E, V, K, L, 2, 3, 4, 5	W, A, Y, B, E, V, 2, 3	Y, B, V, 3	W, A, Y, B, E, V, 2, 3	Y, B, V, 3	•

* Intrinsic safe connection between Electronic module and Vibrating fork

** Intrinsic safe from supply and intrinsic safe between Electronic module and Vibrating fork

Spare parts

Electronic modules VN 2000/ VN 6000

Minimum order value for separate orders of spare parts or accessories is 75 €.

Elektronikmodul	Sensitivity (see pos.26)	Electronic module number	Electronic modules are used for following certificates (see pos. 2 of price lists):				Electronic module				
			VN 2020	VN 2020 VN 2030 separate housing	VN 2030 VN 2040	VN 2050					
Relay (SPDT) 19 .. 230 V AC 19 .. 55 V DC	20 g/l (1,2 lb/ft³)	pl400930	0, W, A, E, 2	0	0, W, A, E, 2	0	VN 6020 0, M, W, A, N, E, 2	VN 6020 temp. extended shaft 0, M, W, A, N, E, 2	VN 6030 VN 6040 0, M, W, A, N, E, 2	VN 6050 0, M	•
	5 g/l (0,3 lb/ft³)	pl400931	0, W, A, E, 2	0	0, W, A, E, 2	0	R, C, S, T, D, U, E, K, L, 2, 4, 5	R, C, S, T, D, U, K, L, 4, 5	R, C, S, T, D, U, K, L, 4, 5	W, A, N, R, C, S, T, D, U, E, K, L, 2, 4, 5	•
Vibrasil® 70	Vibrasil® 90	pl400312	0, W, A, E, 2	0	0, W, A, E, 2	0	0, M, W, A, N, R, C, S, T, D, U, E, K, L, 2, 4, 5		0, M, W, A, N, E, 2	0, M	•
		pl400310	0, W, A, E, 2	0	0, W, A, E, 2	0	0, M, W, A, N, R, C, S, T, D, U, E, K, L, 2, 4, 5		0, M, W, A, N, E, 2	0, M	•
Relay (DPDT) 19 .. 230 V AC 19 .. 55 V DC	20 g/l (1,2 lb/ft³)	pl400124 *	0, W, A, E, 2	0	0, W, A, E, 2	0	0, M, W, A, N, R, C, S, T, D, U, E, K, L, 2, 4, 5		0, M, W, A, N, E, 2	0, M	•
	5 g/l (0,3 lb/ft³)	pl400128 *	0, W, A, E, 2	0	0, W, A, E, 2	0	0, M, W, A, N, R, C, S, T, D, U, E, K, L, 2, 4, 5		0, M, W, A, N, E, 2	0, M	•
Relay (DPDT) 19 .. 230 V AC 19 .. 55 V DC	20 g/l (1,2 lb/ft³)	pl400193	0, W, A, E, 2	0	0, W, A, E, 2	0	0, M, W, A, N, R, C, S, T, D, U, E, K, L, 2, 4, 5		0, M, W, A, N, E, 2	0, M	•
	5 g/l (0,3 lb/ft³)	pl400194	0, W, A, E, 2	0	0, W, A, E, 2	0	0, M, W, A, N, R, C, S, T, D, U, E, K, L, 2, 4, 5		0, M, W, A, N, E, 2	0, M	•
19 .. 230 V AC 19 .. 36 V DC	20 g/l (1,2 lb/ft³)	pl400050 *	0, W, A, E, 2	0	0, W, A, E, 2	0	0, M, W, A, N, R, C, S, T, D, U, E, K, L, 2, 4, 5		0, M, W, A, N, E, 2	0, M	•
	5 g/l (0,3 lb/ft³)	pl400051 *	0, W, A, E, 2	0	0, W, A, E, 2	0	0, M, W, A, N, R, C, S, T, D, U, E, K, L, 2, 4, 5		0, M, W, A, N, E, 2	0, M	•
PNP 18 .. 50 V DC	20 g/l (1,2 lb/ft³)	pl400176	0, W, A, E, 2	0	0, W, A, E, 2	0	0, M, W, A, N, R, C, S, T, D, U, E, K, L, 2, 4, 5		0, M, W, A, N, E, 2	0, M	•
	5 g/l (0,3 lb/ft³)	pl400173	0, W, A, E, 2	0	0, W, A, E, 2	0	0, M, W, A, N, R, C, S, T, D, U, E, K, L, 2, 4, 5		0, M, W, A, N, E, 2	0, M	•
2-wire without contact 19 .. 230 V AC/ DC	20 g/l (1,2 lb/ft³)	pl400127 *	0, W, A, E, 2	0	0, W, A, E, 2	0	0, M, W, A, N, R, C, S, T, D, U, E, K, L, 2, 4, 5		0, M, W, A, N, E, 2	0, M	•
	5 g/l (0,3 lb/ft³)	pl400131 *	0, W, A, E, 2	0	0, W, A, E, 2	0	0, M, W, A, N, R, C, S, T, D, U, E, K, L, 2, 4, 5		0, M, W, A, N, E, 2	0, M	•
20 g/l (1,2 lb/ft³)	20 g/l (1,2 lb/ft³)	pl400182	0, W, A, E, 2	0	0, W, A, E, 2	0	0, M, W, A, N, R, C, S, T, D, U, E, K, L, 2, 4, 5		0, M, W, A, N, E, 2	0, M	•
	5 g/l (0,3 lb/ft³)	pl400187	0, W, A, E, 2	0	0, W, A, E, 2	0	0, M, W, A, N, R, C, S, T, D, U, E, K, L, 2, 4, 5		0, M, W, A, N, E, 2	0, M	•
20 g/l (1,2 lb/ft³)	20 g/l (1,2 lb/ft³)	pl400126	0, W, A, E, 2	0	0, W, A, E, 2	0	0, M, W, A, N, R, C, S, T, D, U, E, K, L, 2, 4, 5		0, M, W, A, N, E, 2	0, M	•
	5 g/l (0,3 lb/ft³)	pl400130	0, W, A, E, 2	0	0, W, A, E, 2	0	0, M, W, A, N, R, C, S, T, D, U, E, K, L, 2, 4, 5		0, M, W, A, N, E, 2	0, M	•
20 g/l (1,2 lb/ft³)	20 g/l (1,2 lb/ft³)	pl400126 *	0, W, A, E, 2	0	0, W, A, E, 2	0	0, M, W, A, N, R, C, S, T, D, U, E, K, L, 2, 4, 5		0, M, W, A, N, E, 2	0, M	•
	5 g/l (0,3 lb/ft³)	pl400130 *	0, W, A, E, 2	0	0, W, A, E, 2	0	0, M, W, A, N, R, C, S, T, D, U, E, K, L, 2, 4, 5		0, M, W, A, N, E, 2	0, M	•
NAMUR EC 60947-5-6 2-wire intrinsic safe	20 g/l (1,2 lb/ft³)	pl400081 **	0, W, A, E, 2	0	0, W, A, E, 2	0	0, M, W, A, N, R, C, S, T, D, U, E, K, L, 2, 4, 5		0, M, W, A, N, E, 2	0, M	•
	5 g/l (0,3 lb/ft³)	pl400082 **	0, W, A, E, 2	0	0, W, A, E, 2	0	0, M, W, A, N, R, C, S, T, D, U, E, K, L, 2, 4, 5		0, M, W, A, N, E, 2	0, M	•
8/16 mA 2-wire	20 g/l (1,2 lb/ft³)	pl400060*	0, W, A, E, 2	0	0, W, A, E, 2	0	0, M, W, A, N, R, C, S, T, D, U, E, K, L, 2, 4, 5		0, M, W, A, N, E, 2	0, M	•
	5 g/l (0,3 lb/ft³)	pl400061*	0, W, A, E, 2	0	0, W, A, E, 2	0	0, M, W, A, N, R, C, S, T, D, U, E, K, L, 2, 4, 5		0, M, W, A, N, E, 2	0, M	•
8/16 mA or 4-20 mA	20 g/l (1,2 lb/ft³)	pl400094	0, W, A, E, 2	0	0, W, A, E, 2	0	0, M, W, A, N, R, C, S, T, D, U, E, K, L, 2, 4, 5		0, M, W, A, N, E, 2	0, M	•
	5 g/l (0,3 lb/ft³)	pl400098	0, W, A, E, 2	0	0, W, A, E, 2	0	0, M, W, A, N, R, C, S, T, D, U, E, K, L, 2, 4, 5		0, M, W, A, N, E, 2	0, M	•
8/16 mA or 4-20 mA 2-wire intrinsic safe	20 g/l (1,2 lb/ft³)	pl400091 **	0, W, A, E, 2	0	0, W, A, E, 2	0	0, M, W, A, N, R, C, S, T, D, U, E, K, L, 2, 4, 5		0, M, W, A, N, E, 2	0, M	•
	5 g/l (0,3 lb/ft³)	pl400092 **	0, W, A, E, 2	0	0, W, A, E, 2	0	0, M, W, A, N, R, C, S, T, D, U, E, K, L, 2, 4, 5		0, M, W, A, N, E, 2	0, M	•

* Intrinsic safe connection between Electronic module and Vibrating fork
 ** Intrinsic safe from supply and intrinsic safe between Electronic module and Vibrating fork